

MELSEC L-Series

Programmable Logic Controllers

User's Manual

PROFIBUS DP Master Module ME1PB1-L



User's Manual
ME1PB1-L PROFIBUS DP Master Module
Art. no.: 270469

Version	Revisions / Additions / Corrections
A 10/2013 pdp-dk	First edition

About this manual

The texts, illustrations, diagrams and examples in this manual are provided for information purposes only. They are intended as aids to help explain the installation, operation, programming and use of the programmable controllers of the Mitsubishi MELSEC-L series.

If you have any questions about the installation and operation of any of the products described in this manual please contact your local sales office or distributor (see back cover).

You can find the latest information and answers to frequently asked questions on our website at www.mitsubishi-automation.com.

MITSUBISHI ELECTRIC EUROPE B.V. reserves the right to make changes to this manual or the technical specifications of its products at any time without notice.

© 2013

MITSUBISHI ELECTRIC EUROPE B.V.

Safety guidelines

For use by qualified staff only

This manual is only intended for use by properly trained and qualified electrical technicians who are fully acquainted with the relevant automation technology safety standards. All work with the hardware described, including system design, installation, configuration, maintenance, service and testing of the equipment, may only be performed by trained electrical technicians with approved qualifications who are fully acquainted with all the applicable automation technology safety standards and regulations. Any operations or modifications to the hardware and/or software of our products not specifically described in this manual may only be performed by authorized Mitsubishi Electric staff.

Proper use of the products

The ME1PB1-L PROFIBUS DP Master Module is only intended for the specific applications explicitly described in this manual. All parameters and settings specified in this manual must be observed. The products described have all been designed, manufactured, tested and documented in strict compliance with the relevant safety standards.

Unqualified modification of the hardware or software or failure to observe the warnings on the products and in this manual may result in serious personal injury and/or damage to property. Only peripherals and expansion equipment specifically recommended and approved by Mitsubishi Electric may be used with the programmable controllers of the MELSEC-L series.

All and any other uses or application of the products shall be deemed to be improper.

Relevant safety regulations

All safety and accident prevention regulations relevant to your specific application must be observed in the system design, installation, configuration, maintenance, servicing and testing of these products. The regulations listed below are particularly important in this regard.

This list does not claim to be complete; however, you are responsible for being familiar with and conforming to the regulations applicable to you in your location.

- VDE Standards
 - VDE 0100
Regulations for the erection of power installations with rated voltages below 1000 V
 - VDE 0105
Operation of power installations
 - VDE 0113
Electrical installations with electronic equipment
 - VDE 0160
Electronic equipment for use in power installations
 - VDE 0550/0551
Regulations for transformers
 - VDE 0700
Safety of electrical appliances for household use and similar applications
 - VDE 0860
Safety regulations for mains-powered electronic appliances and their accessories for household use and similar applications.
- Fire safety regulations
- Accident prevention regulation
 - VBG No. 4
Electrical systems and equipment

Safety warnings in this manual

In this manual special warnings that are important for the proper and safe use of the products are clearly identified as follows:



DANGER:

Personnel health and injury warnings.

Failure to observe the safety warnings identified with this symbol can result in health and injury hazards for the user.



CAUTION:

Equipment and property damage warnings.

Failure to observe the safety warnings identified with this symbol can result in damage to the equipment or other property.

General safety information and precautions

The following safety precautions are intended as a general guideline for using PLC systems together with other equipment. These precautions must always be observed in the design, installation and operation of all control systems.



DANGER:

- **Observe all safety and accident prevention regulations applicable to your specific application. Always disconnect all power supplies before performing installation and wiring work or opening any of the assemblies, components and devices.**
- **Assemblies, components and devices must always be installed in a shockproof housing fitted with a proper cover and fuses or circuit breakers.**
- **Devices with a permanent connection to the mains power supply must be integrated in the building installations with an all-pole disconnection switch and a suitable fuse.**
- **Check power cables and lines connected to the equipment regularly for breaks and insulation damage. If cable damage is found immediately disconnect the equipment and the cables from the power supply and replace the defective cabling.**
- **Before using the equipment for the first time check that the power supply rating matches that of the local mains power.**
- **Take appropriate steps to ensure that cable damage or core breaks in the signal lines cannot cause undefined states in the equipment.**
- **You are responsible for taking the necessary precautions to ensure that programs interrupted by brownouts and power failures can be restarted properly and safely. In particular, you must ensure that dangerous conditions cannot occur under any circumstances, even for brief periods. EMERGENCY OFF must be switched forcibly, if necessary.**
- **Residual current protective devices pursuant to DIN VDE Standard 0641 Parts 1-3 are not adequate on their own as protection against indirect contact for installations with PLC systems. Additional and/or other protection facilities are essential for such installations.**
- **EMERGENCY OFF facilities conforming to EN 60204/IEC 204 and VDE 0113 must remain fully operative at all times and in all control system operating modes. The EMERGENCY OFF facility reset function must be designed so that it cannot ever cause an uncontrolled or undefined restart.**
- **You must implement both hardware and software safety precautions to prevent the possibility of undefined control system states caused by signal line cable or core breaks.**
- **When using modules always ensure that all electrical and mechanical specifications and requirements are observed exactly.**
- **Do not install/remove the module more than 50 times after the first use of the product (conforming to IEC 61131-2). Failure to do so may cause the module to malfunction due to poor contact of connector.**

Precautions to prevent damages by electrostatic discharge

Electronic devices and modules can be damaged by electrostatic charge, which is conducted from the human body to components of the controller. Always take the following precautions, when handling the controller.



CAUTION:

- **Before touching a module of the controller, always touch grounded metal, etc. to discharge static electricity from human body. Failure to do so may cause the module to fail or malfunction.**
- **Wear isolating gloves when touching the powered controller, e. g. at maintenance during visual check.**
- **You shouldn't wear clothing made of synthetic fiber at low humidity. This clothing gets a very high rate of electrostatic charge.**

Design Precautions



DANGER:

- **When a communication error occurs on PROFIBUS DP, the status of the faulty station is as shown below.**

Create an interlock circuit in the sequence program using the communication status information to ensure the system operates safely (Input Xn1, buffer memory addresses 5A20H to 5B19H (23072 to 23321)).

An erroneous output or malfunction may cause accidents.

- **The ME1PB1-L holds the input data before the communication failure.**
- **When the ME1PB1-L has gone down, the output status of each DP-Slave is dependent on the ME1PB1-L parameter setting in the intelligent function utility.**
- **When a DP-Slave has gone down, the output status of the other DP-Slaves is dependent on the ME1PB1-L parameter setting in the intelligent function utility.**

- **Do not output the "use prohibited" signal as the output signal to an intelligent function module from the programmable controller CPU.**

Doing so may cause malfunction of the programmable controller system.

- **When a stop error has occurred to the CPU module, the communication status varies depending on the error time output mode setting of GX Works2 as shown below.**

Set the communication status for when a stop error has occurred to the CPU module according to the system specifications.

- **When "Error time output mode" is set to "Hold".**

Since the communication with the DP-Slave is continued, values at the time of the CPU module stop error occurrence are held as the output data sent to the DP-Slave from the ME1PB1-L.

Input data received from DP-Slaves are updated into the buffer memory of the ME1PB1-L.

- **When "Error time output mode" is set to "Clear".**

Communications with DP-Slaves are interrupted, and output data are not sent.

Input data received from DP-Slaves are held in the buffer memory of the ME1PB1-L.

Installation Precautions



CAUTION:

- **Do not install PROFIBUS cables together with the main circuit or power lines or bring them close to each other.**
Keep a distance of 100 mm or more between them.
Failure to do so may result in malfunction due to noise.
- **Use the programmable controller in an environment that meets the general specifications in the user's manual for the CPU module used.**
Failure to do so may result in electric shock, fire, malfunction, or damage to or deterioration of the product.
- **Shut off the external power supply (all phases) used in the system before mounting or removing the module.**
Failure to do so may result in damage to the product.
- **Do not directly touch any conductive parts and electronic components of the module.**
Doing so can cause malfunction or failure of the module.
- **To interconnect modules, engage the respective connectors and securely lock the module joint levers.**
Incorrect interconnection may cause malfunction, failure, or drop of the module.

Wiring precautions



CAUTION:

- **Be sure to shut off all phases of the external power supply used by the system before wiring PROFIBUS cables.**
Failure to do so may cause the module to fail or malfunction.
- **Prevent foreign matter such as dust or wire chips from entering the module.**
Such foreign matter can cause a fire, failure, or malfunction.
- **Be sure to place the PROFIBUS cables in a duct or clamp them.**
If not, dangling cable may swing or inadvertently be pulled, resulting in damage to the module or cables or malfunction due to poor contact.
- **When disconnecting the PROFIBUS cable, do not pull it by holding the cable part.**
Be sure to hold its connector which is plugged into the module. Pulling the cable with it connected to the module may damage the module and/or cable, or cause malfunctions due to poor contact of the cable.

Startup and maintenance precautions



DANGER:

Shut off the external power supply (all phases) used in the system before cleaning the module. Failure to do so may result in electric shock or cause the module to fail or malfunction.



CAUTION:

- ***Do not disassemble or modify the modules. Doing so may cause failure, malfunction, injury, or a fire.***
- ***Use any radio communication device such as a cellular phone or PHS (Personal Handy-phone System) more than 25 cm away in all directions from the programmable controller. Failure to do so may cause malfunction.***
- ***Shut off the external power supply (all phases) used in the system before mounting or removing the module. Failure to do so may cause the module to fail or malfunction.***
- ***Module installation to or removal from the base unit is limited to 50 times after the first use of the product (IEC61131-2 compliant). Exceeding 50 times may cause malfunctions.***
- ***Before handling modules, touch a grounded metal object to discharge the static electricity from the human body. Not doing so may cause failure or malfunctions of the module.***
- ***Set the ON/OFF select switch of the terminal resistor before the operation. If the setting is switched during the operation, network error may occur, or error detection may not be performed by error.***

Operating precautions



DANGER:

Do not write data into the "not usable" of the buffer memory of special function modules. Also, do not output the "not usable" signal as the output signal to a special function module from the PLC CPU.

Writing data into the "not usable area" or outputting an "not usable" signal may cause system malfunctions in the PLC.



CAUTION:

The online operations conducted for the CPU module being operated (especially when changing data or operation status), shall be conducted after the manual has been carefully read and a sufficient check of safety has been conducted.

Operation mistakes could cause breakdowns to or malfunction of the module.

Disposal precautions



CAUTION:

When disposing of this product, treat is as an industrial waste.

Symbols used in the manual

Use of notes

Notes concerning important information are marked separately and are displayed as follows:

NOTE

| Note text

Use of numbering in the figures

Numbering within the figures is displayed by white numbers within black circles and is explained in a table following it using the same number, e.g.:

① ② ③ ④

Use of handling instructions

Handling instructions are steps that must be carried out in their exact sequence during startup, operation, maintenance and similar operations.

They are numbered consecutively (black numbers in white circles):

- ① Text.
- ② Text.
- ③ Text.

Use of footnotes in tables

Instructions in tables are explained in footnotes underneath the tables (in superscript). There is a footnote character at the appropriate position in the table (in superscript).

If there are several footnotes for one table then these are numbered consecutively underneath the table (black numbers in white circle, in superscript):

- ① Text
- ② Text
- ③ Text

Writing conventions and guidance notes

Keys or key-combinations are indicated in square brackets, such as [Enter], [Shift] or [Ctrl]. Menu names of the menu bar, of the drop-down menus, options of a dialogue screen and buttons are indicated in italic bold letters, such as the drop down menu ***New*** in the ***Project*** menu or the option ***Serial USB*** in the "Transfer Setup Connection" screen.

Contents

1	Overview	
1.1	Features.....	1-2
1.1.1	DP-Master (class 1) on PROFIBUS DP.....	1-2
1.2	Abbreviations and Generic Terms	1-4
2	System Configuration	
2.1	Total Configuration.....	2-1
2.1.1	Applicable System	2-1
2.1.2	Restrictions when the ME1PB1-L is connected to a head module	2-1
2.1.3	How to check the function version and serial No. of the modules	2-1
2.2	PROFIBUS DP Network Configuration	2-2
2.2.1	Basic configuration of the PROFIBUS DP network	2-2
2.2.2	PROFIBUS DP Network Configuration Examples.....	2-3
3	Specifications	
3.1	General Specifications	3-1
3.2	Performance Specifications	3-2
3.3	Data and Signal Transfer	3-4
3.4	Function List	3-5
3.5	I/O-Signals for the PLC-CPU	3-6
3.5.1	List of I/O Signals	3-6
3.5.2	Details of I/O Signals.....	3-7
3.6	Buffer Memory	3-16
3.6.1	Buffer memory list	3-17
3.6.2	Local station information area.....	3-20
3.6.3	Operation mode change area	3-21
3.6.4	I/O data exchange area	3-22
3.6.5	Slave status area.....	3-27
3.6.6	Diagnostic information area.....	3-34
3.6.7	Extended diagnostic information read area.....	3-39
3.6.8	Bus cycle time area	3-40
3.6.9	Global control area	3-40
3.6.10	Acyclic communication area	3-42
3.6.11	Alarm area.....	3-46
3.6.12	Time control area.....	3-46
3.6.13	Temporary slave reservation area	3-47
3.7	Processing Times	3-49
3.7.1	Bus Cycle Time	3-49
3.7.2	Transmission delay time	3-53

4	Functions	
4.1	PROFIBUS DPV0 Functions	4-2
4.1.1	I/O Data Exchange	4-2
4.1.2	Acquisition of Diagnostic and/or Extended Diagnostic Information	4-4
4.1.3	Global Control Function	4-6
4.2	PROFIBUS DPV1 Functions	4-10
4.2.1	Acyclic Communication with DP-Slaves	4-10
4.2.2	Alarm Acquisition	4-12
4.3	PROFIBUS DPV2 Functions	4-15
4.3.1	Time Control over DP-Slaves	4-15
4.4	Data Swap Function	4-17
4.4.1	Data swap setting	4-17
4.4.2	Invalidating or validating data swap setting	4-18
4.5	Data Consistency Function	4-19
4.5.1	I/O data consistency function	4-19
4.5.2	How to prevent data inconsistency	4-20
4.5.3	Precautions	4-21
4.6	Output Status Setting for the Case of a CPU Stop Error	4-22
4.6.1	Output status setting for the case of a CPU stop error	4-22
4.6.2	Output status for the case of a CPU stop error	4-23
4.7	Temporary Slave Reservation Function	4-24
4.7.1	DP-Slaves that can be changed to temporarily reserved stations	4-24
4.7.2	Temporary slave reservation specification and cancellation	4-24
4.8	Mode Change Function	4-25
5	Settings and Procedures before System Operation	
5.1	Implementation and Installation	5-1
5.1.1	Handling precautions	5-1
5.2	Procedures Before System Operation	5-2
5.3	Part Names and Settings	5-3
5.3.1	Indicator LEDs	5-4
5.4	Self-diagnostics	5-5
5.4.1	Self-diagnostics execution procedure	5-5
5.4.2	Execution result of self-diagnostics	5-5
5.5	Wiring	5-6
5.5.1	Pin assignments of the PROFIBUS interface connector	5-6
5.5.2	PROFIBUS cable	5-6
5.5.3	Wiring precautions	5-8
5.6	Intelligent Function Utility (GX Works2)	5-9
5.6.1	Addition of a new module to the project	5-9
5.6.2	Parameter setting	5-11
5.6.3	Auto refresh settings	5-12
5.6.4	Writing the intelligent function module settings to the PLC	5-13

6	Parameter Setting	
6.1	Parameter Setting Procedure	6-1
6.2	Operation Mode Setting	6-2
6.2.1	Types of operation modes	6-2
6.2.2	Operation mode change	6-2
6.2.3	Error codes for the operation mode change failure	6-2
6.2.4	Precautions when changing the operation mode	6-3
6.3	Master Parameters	6-4
6.3.1	Start procedure	6-4
6.3.2	Setting items	6-4
6.4	Bus Parameters	6-6
6.4.1	Start procedure	6-6
6.4.2	Setting items	6-6
6.4.3	Precautions for bus parameter setting	6-7
6.5	Slave Parameters	6-8
6.5.1	Start procedure	6-8
6.5.2	Setting items	6-8
6.5.3	DP V1/V2 Slave Parameters screen	6-10
6.6	Automatic Refresh Parameters	6-12
6.6.1	Automatic refresh parameter setup procedure	6-12
6.6.2	Automatic refresh settings	6-14
6.6.3	Slave Specific Buffer Devices window	6-16
6.6.4	Writing automatic refresh parameters	6-17
6.6.5	Number of set automatic refresh parameters	6-18
6.7	PLC Parameter Setting by GX Works2	6-20
7	Programming	
7.1	I/O Data Exchange Program Examples	7-2
7.1.1	Program examples using automatic refresh	7-6
7.1.2	Program example using dedicated instructions	7-10
7.1.3	Program example using MOV instructions	7-12
7.2	Program Example for Acquisition of Extended Diagnostic Error Information	7-14
7.3	Program Example for Global Control Function	7-16
7.4	Program Example for Acyclic Communication with DP-Slaves	7-17
7.4.1	READ services (Class1_SERVICE, Class2_SERVICE)	7-19
7.4.2	WRITE services (Class1_SERVICE, Class2_SERVICE)	7-22
7.4.3	INITIATE service (Class2_SERVICE)	7-25
7.4.4	ABORT service (Class2_SERVICE)	7-28
7.4.5	Program example	7-30
7.5	Program Example for Alarm Acquisition	7-32
7.5.1	Alarm read request (without ACK)	7-33
7.5.2	Alarm ACK request	7-36
7.5.3	Alarm read request (with ACK)	7-41
7.5.4	Program example	7-47

7.6	Program Example for Time Control over DP-Slaves	7-49
7.6.1	Time data read request	7-50
7.6.2	Time data write request (UTC format).....	7-51
7.6.3	Time data write request.....	7-52
7.6.4	Program example.....	7-53
7.7	Program Example for Temporary Slave Reservation	7-55
7.8	Program Examples when the ME1PB1-L is Mounted to a CC-Link IE Field Network Head Module	7-56
7.8.1	System configuration for the examples	7-56
7.8.2	I/O Assignment for both examples	7-57
7.8.3	Use of auto refresh for transfer of input/output data	7-58
7.8.4	Use of REMTO/REMF instructions for transfer of input/output data	7-67

8 Dedicated Instructions

8.1	Precautions for Dedicated Instructions	8-2
8.2	G. BBLKRD.....	8-4
8.3	G. BBLKWR	8-6

9 Troubleshooting

9.1	Error Check Using the LEDs and Corrective Actions	9-2
9.1.1	Causes and actions	9-2
9.1.2	Checking the LED status on GX Works2	9-3
9.2	When Parameters cannot be Written from GX Works2	9-4
9.3	When Communication with DP-Slaves is not Possible.....	9-5
9.4	Error Codes.....	9-7
9.4.1	Error codes E200H to E2FFH (Error codes generated when reading extended diagnostic information)	9-8
9.4.2	Error codes E300H to E3A3H (Error codes generated when switching operation mode)	9-8
9.4.3	Error codes E400H to E4E3H (Error codes generated during acyclic communication)	9-9
9.4.4	Error codes E500H to E5A2H (Error codes generated when reading alarms)	9-13
9.4.5	Error codes E600H to E62DH (Error codes generated when executing time control).....	9-16
9.4.6	Error codes F100H to FFB1H (Local diagnostic information of the ME1PB1-L).....	9-17
9.5	How to Return the ME1PB1-L to its Factory-set Conditions	9-19

A Appendix

A.1	External Dimensions.....	A-1
-----	--------------------------	-----

1 Overview

This manual explains the specifications, functions, procedures before system operation, and troubleshooting for the ME1PB1-L PROFIBUS DP master module (hereinafter referred to as "ME1PB1-L").

The ME1PB1-L is used for connecting MELSEC-L series programmable controllers to PROFIBUS DP. The ME1PB1-L operates as a DP-Master (Class 1) on PROFIBUS DP networks.

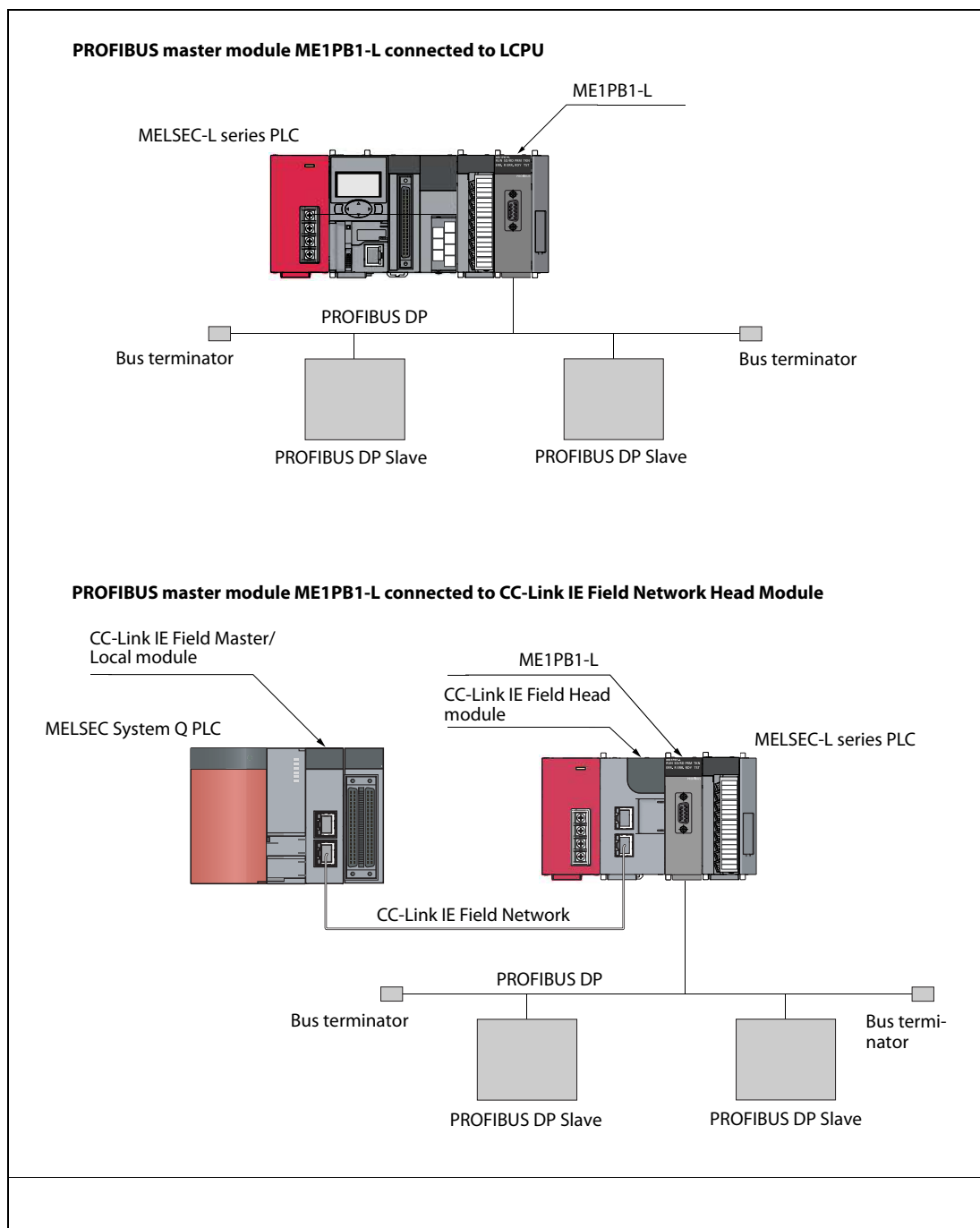

Fig. 1-1: PROFIBUS DP using ME1PB1-L

1.1 Features

The following describes the features of the ME1PB1-L.

1.1.1 DP-Master (class 1) on PROFIBUS DP

The ME1PB1-L complies with IEC 61158, and operates as a DP-Master (Class 1) on PROFIBUS DP systems.

Up to 125 DP-Slaves are connectable

Up to 125 DP-Slaves can be connected to a single ME1PB1-L, enabling exchange of I/O data up to 8192 bytes. (Refer to section 4.1.1)

Diagnostic information can be easily acquired

Diagnostic or extended diagnostic information of an error occurred on a DP-Slave during I/O data exchange can be easily acquired using the buffer memory and I/O signals. (Refer to section 4.1.2)

Supporting the global control function

By sending services (SYNC, UNSYNC, FREEZE, UNFREEZE) to each DP-Slave in a group, synchronous control of DP-Slave I/O data is available. (Refer to section 4.1.3)

Service name	Description
SYNC	This service is for synchronizing the output status of DP-Slaves. In the SYNC mode, the output status of a DP-Slave is refreshed each time it receives the SYNC service. While no SYNC service is received, the output status is held.
UNSYNC	This service is for ending the SYNC mode.
FREEZE	This service is for synchronizing the input status of DP-Slaves. In the FREEZE mode, the input status of a DP-Slave is refreshed each time it receives the FREEZE service. While no FREEZE service is received, the input status is held.
UNFREEZE	This service is for ending the FREEZE service.

Tab. 1-1: Descriptions of services

Supporting PROFIBUS DPV1 and PROFIBUS DPV2

PROFIBUS DPV1 and PROFIBUS DPV2, which are extended versions of PROFIBUS DP, are supported.

The ME1PB1-L supports the following:

- PROFIBUS DPV1
 - Acyclic communication with DP-Slaves (refer to section 4.2.1)
 - Alarm acquisition (refer to section 4.2.2)
- PROFIBUS DPV2
 - Time control function on DP-Slaves (refer to section 4.3.1)
- I/O data consistency

Using the automatic refresh setting in the intelligent function utility or dedicated instructions (BBLKRD/BBLKWR) ensures data consistency when reading/writing I/O data from the ME1PB1-L buffer memory. (Refer to section 4.5)

- Easy parameter setup
Use of intelligent function utility of GX Works2 enables bus parameters, master parameters, slave parameters, and various other parameters to be easily set up. (Refer to chapter 6)
- Swapping of I/O data
The upper and lower bytes can be reversed (swapped) in word units when I/O data is sent or received.
This simplifies programming as you no longer need to create a program for swapping the upper and lower bytes on the ME1PB1-L or DP-Slave. (Refer to section 4.4)
- Mountable on CC-Link IE Field network station
The ME1PB1-L can be mounted on a station in a CC-Link IE Field network. This allows you to install the ME1PB1-L at a remote site away from the PLC CPU. (Refer to section 7.8)
- Output status setting for the case of a CPU stop error (Stop/Continue of I/O data exchange)
For the case of a CPU stop error on a L series CPU or CC-Link IE station where the ME1PB1-L is mounted, whether to stop or continue I/O data exchange with DP-Slaves can be specified. (Refer to section 4.6)
- Changing DP-Slave setting to reserved station status temporarily
Without modifying the slave parameter in the intelligent function utility, the station type of DP-Slaves can be changed to "Reserved station" temporarily. (Refer to section 4.7)
Since there is no need to change slave parameters, changing a DP-Slave setting to a reserved station is easy.

1.2 Abbreviations and Generic Terms

Unless otherwise specified, this manual uses the following generic terms and abbreviations to describe the ME1PB1-L PROFIBUS DP Master Module.

General term / Abbreviation		Description
ME1PB1-L		Abbreviation for the ME1PB1-L PROFIBUS DP Master module.
PROFIBUS DP		Abbreviation of PROFIBUS DP network
CC-Link IE		Abbreviation of CC-Link IE network system
MELSEC-L CPU		Generic term for L series CPU modules, e.g. L02CPU, L02CPU-P, L26CPU-BT and L26CPU-PBT, etc.
L26CPU		
PLC CPU		
CPU module		Generic term for programmable controller.
GX Works2		Generic product name for the programming and configuration software GX Works2.
BBLKRD		Abbreviation for the G. BBLKRD instruction
BBLKWR		Abbreviation for the G. BBLKWR instruction
PROFIBUS DPV0		A basic version of PROFIBUS DP. The following functions are executable: <ul style="list-style-type: none"> • I/O data exchange • Diagnostic information notification etc.
PROFIBUS DPV1		A PROFIBUS DP version for which the following functions have been added to the basic functionality of PROFIBUS DPV0. <ul style="list-style-type: none"> • Acyclic communication • Alarm function etc.
PROFIBUS DPV2		A PROFIBUS DP version for which the following functions have been added to the PROFIBUS DPV1 functionality. <ul style="list-style-type: none"> • Time stamping etc.
DP-Master	Class 1	A device exchanging I/O data with a DP-Slave.
	Class 2	A device that communicates with DP-Slaves and checks their FDL address settings and/or operation states. The DP-Master (Class 2) is used as a DP-Master for supervising the network, which can start, maintain, and diagnose the system.
DP-Slave		A device that exchanges I/O data with a DP-Master (Class 1). (QJ71PB93D, ST1H-PB, etc.).
Repeater		A device used to connect different segments of PROFIBUS DP.
Bus terminator		A terminating resistor that is connected to either end of each segment on PROFIBUS DP.
GSD file		An electronic file that contains parameters of a DP-Slave. The GSD file is used to set up the slave parameters on the intelligent function utility.
FDL address		The numbers assigned to a DP-Master and DP-Slaves. The FDL address is set within the range from 0 to 125.
Bus parameter		The parameter used for the communication setting of PROFIBUS DP. The bus parameter is set up on the intelligent function utility.
Master parameter		The parameter used for the settings (FDL address, transmission speed, etc.) of the ME1PB1-L. The master parameter is set up on the intelligent function utility.
Slave parameter		The parameter for a DP-Slave, which is set on the DP-Master. The slave parameter is set up on the intelligent function utility. The setting items are described on the GSD File.
I/O configuration data		Information on input/output configuration of a DP-Slave
I/O data exchange		This function allows I/O data exchange between a DP-Master (Class 1) and DP-Slaves.
Global control		This function enables synchronization command transmission for I/O data from a DP-Master (Class 1) to DP-Slaves.
Diagnostic information		Diagnostic information of PROFIBUS DP, which is detected by a DP-Master or notified by a DP-Slave
Extended diagnostic error information		Diagnostic information specific to each DP-Slave Each of DP-Slaves notifies of it to the DP-Master when an error is detected.

Tab. 1-2: Abbreviations and general terms (1)

General term / Abbreviation	Description
Bus cycle time	PROFIBUS DP processing time for the DP-Master to perform cyclic communication with each DP-Slave
Ident No.	A specific number for each module that is connected to PROFIBUS DP. Ident No. is described in a GSD file of each module.
UTC	UTC stands for Coordinated Universal Time. UTC is the primary time standard by which the world regulates clocks and time. It is one of several closely related successors to Greenwich Mean Time (GMT).
Time master	A master station that can send a request for time control. (ME1PB1-L, etc.)

Tab. 1-2: *Abbreviations and general terms (2)*

2 System Configuration

This chapter describes the overall configuration, number of connectable modules, and compatible software version of the ME1PB1-L.

2.1 Total Configuration

The ME1PB1-L can be connected to a CPU module, an extension module or a CC-Link IE Field network head module.

2.1.1 Applicable System

For the number of connectable modules and the compatible software version, refer to the following.

- MELSEC-L CPU Module User's Manual (Hardware Design, Maintenance and Inspection)
- MELSEC-L CC-Link IE Field Network Head Module User's Manual

2.1.2 Restrictions when the ME1PB1-L is connected to a head module

When the ME1PB1-L is connected to a CC-Link IE Field network head module LJ72GF15-T2, dedicated instructions (BBLKWR, BBLKRD) cannot be used. Data consistency between the head module and the ME1PB1-L is also not supported.

2.1.3 How to check the function version and serial No. of the modules

The serial No. and function version can be checked on the label attached to the right side of the module.

Using the programming software GX Developer or GX Works2, the serial No. and the function version can be checked while the PLC is operating.

From the **Diagnostics** menu select **System Monitor** and then select **Product Information List**.

Block	Slot	Type	Series	Model Name	Point	I/O Address	Serial No.	Ver.	
0	CPU	Display Module	L	L6DSPU	-	-	1111100000000000	A	
0	CPU	CPU	L	L26CPU-BT	-	-	1111200000000000	A	11
0	CPU	Built-in I/O	L	L26CPU-BT	16Point	0000	1111200000000000	A	11
0	CPU	Built-in CC-Link	L	L26CPU-BT	32Point	0010	1111200000000000	A	11
0	0	Input	L	LX40C6	16Point	0030	-	-	-
0	1	Intelli.	L	026ME1PB1-L	32Point	0040	1502300000000000	A	-
0	-	END Cover	-	LbEC	-	-	-	-	-

Model name
Serial number (first 5 digits)
Function version

Fig. 2-1: Product Information List for a PLC with a ME1PB1-L

2.2 PROFIBUS DP Network Configuration

2.2.1 Basic configuration of the PROFIBUS DP network

This section explains the basic PROFIBUS DP configuration for using the ME1PB1-L as a DP-Master (Class 1).

System equipment

The following table shows the equipment required for the PROFIBUS DP system.

System equipment	Description
DP-Master (Class 1)	ME1PB1-L
Configuration tool	GX Works2 version 1.103H or later with GX Configurator DP version 7.09K or later installed.
DP-Slave	QJ71PB93D, ST1H-PB, etc.
Repeater	Required when 32 or more DP-Slaves are connected
PROFIBUS cable	Refer to section 5.5.2
Bus terminator	

Tab. 2-1: System equipment

* GX Configurator DP version 7.09K or later must be installed additionally. The ME1PB1-L can be configured in the intelligent function utility of GX Works2.

Network configuration

In the PROFIBUS DP system configuration, the following conditions must be satisfied:

- Number of connectable modules in an entire network (When repeaters are used)
 - DP-Master ^① + DP-Slaves ≤ 126
 - ^① Including the ME1PB1-L
- Number of connectable modules per segment
 - DP-Master ^① + DP-Slaves + repeaters ^② ≤ 32
 - ^① Including the ME1PB1-L
 - ^② A repeater is counted for both segments.
- Max. no. of repeaters
 - Up to 3 repeaters can be used for communication between the ME1PB1-L and any DP-Slave.
- Number of connectable DP-Slaves per ME1PB1-L
 - Up to 125 DP-Slaves can be connected to a single ME1PB1-L.
- Multi-master system
 - When a communication chip of ASPC2 STEP C mode or equivalent is used, the DP-Master cannot be connected to the PROFIBUS DP in which the ME1PB1-L is included.
 - To use a DP-Master with such a communication chip, configure another network.
 - For the communication chip currently used, consult its manufacturer.

2.2.2 PROFIBUS DP Network Configuration Examples

Maximum configuration with no repeater connected

DP-Master (ME1PB1-L): 1

DP-Slaves: 31

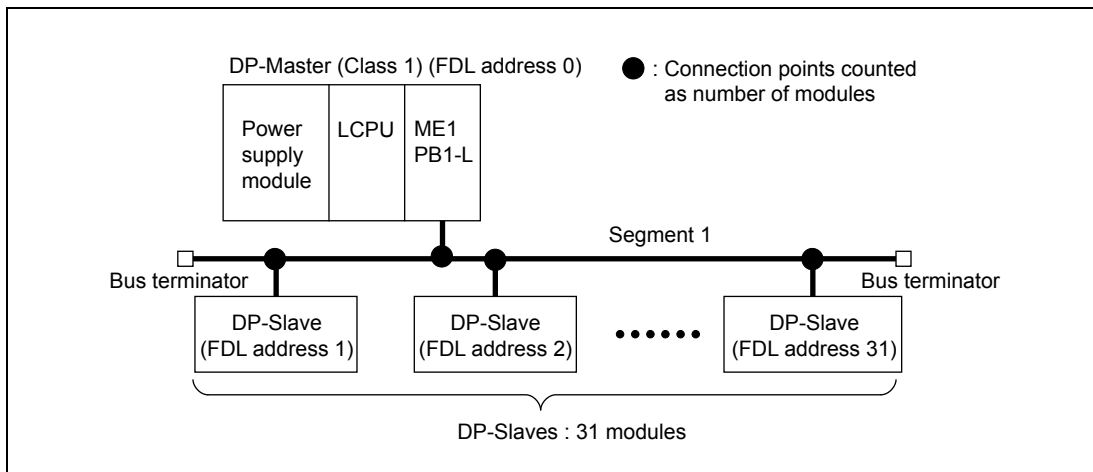

Fig. 2-2: With no repeater, up to 31 slaves can be connected

Maximum configuration with a repeater connected

DP-Master (ME1PB1-L): 1

DP-Slaves: 61

Repeater: 1

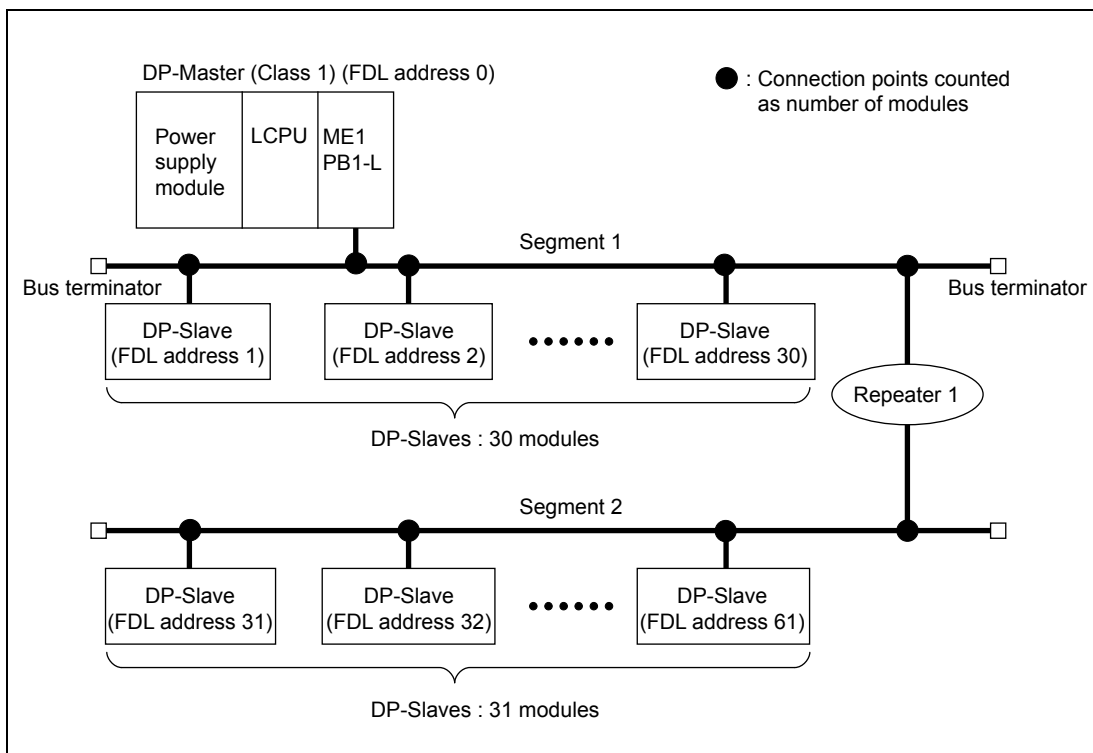

Fig. 2-3: With one repeater, up to 61 slaves can be connected

Maximum configuration when four repeaters are connected

DP-Master (ME1PB1-L): 1
 DP-Slaves: 125
 Repeater: 4

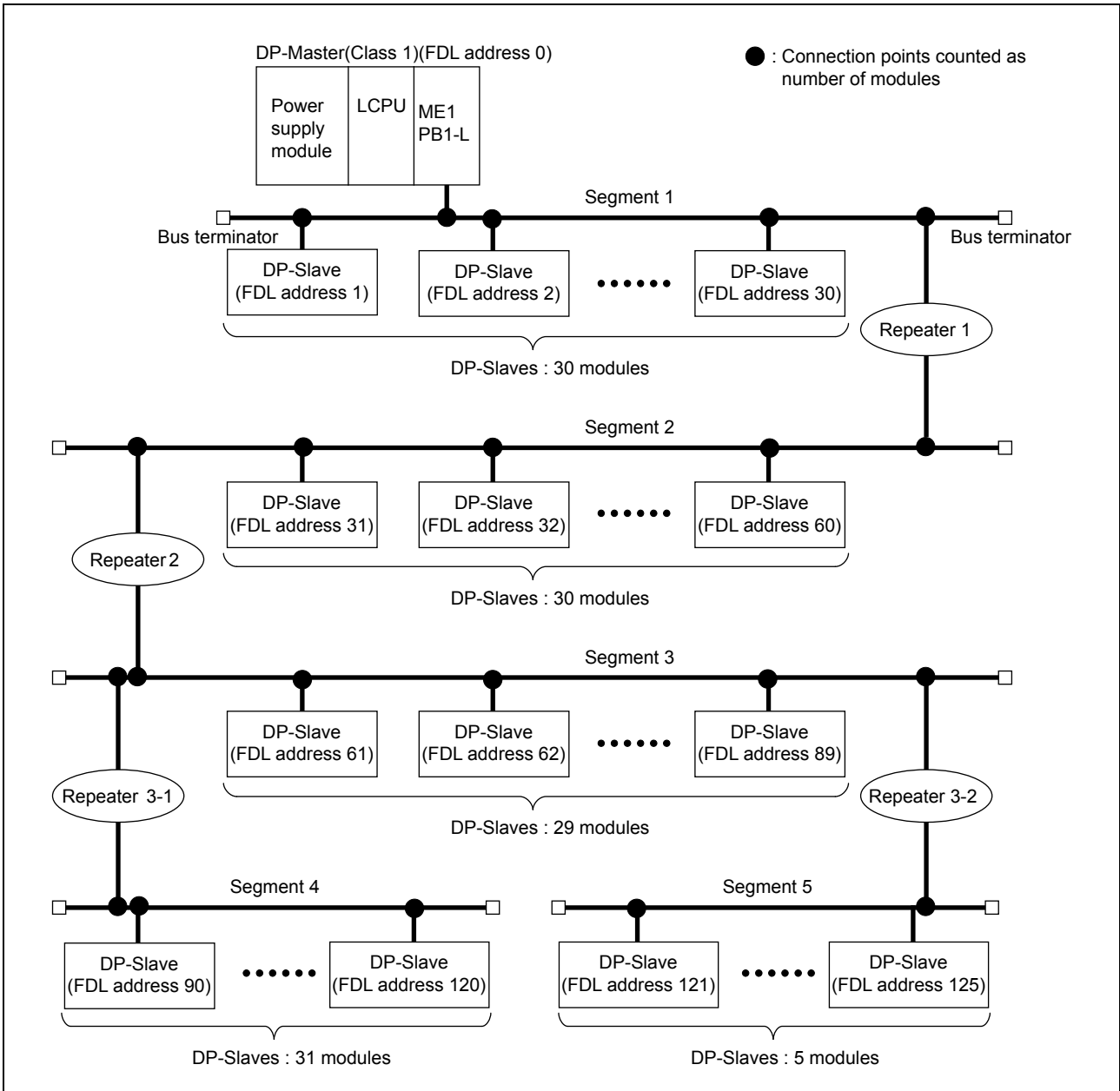

Fig. 2-4: When four repeaters are used, up to 125 DP-Slaves can be connected

When multiple DP-Masters are connected (Multi-master system)

More than one DP-Master with different FDL addresses can be connected to the same network.

3 Specifications

3.1 General Specifications

For the general specifications of the ME1PB1-L, refer to the manual "Safety Guidelines", the manual supplied with the CPU module or head module.

3.2 Performance Specifications

Item		Specifications	
PROFIBUS DP station type		DP-Master (Class 1)	
Transmission specifications	Electrical standard/ characteristics	EIA-RS485 compliant	
	Medium	Shielded twisted pair cable (refer to section 5.5.2)	
	Network topology	Bus topology	
	Data link method	<ul style="list-style-type: none"> Between DP-Master and DP-Master: Token passing method Between DP-Master and DP-Slave: Polling method 	
	Encoding method	NRZ	
	Transmission speed ^①	9.6 kbps to 12 Mbps (refer to tab. 3-2)	
	Transmission distance	Differs depending on the transmission speed (refer to tab. 3-2)	
	Max. No. of repeaters	3 repeaters in line	
	Number of connectable stations	Per segment	32 (including repeater(s))
		Per network	126 (total of DP-Masters and DP-Slaves (refer to section 2.2))
	Max. Number of DP-Slaves per ME1PB1-L	125 (refer to section 2.2)	
	Transmission data size	Input data	Max. 8192 bytes (Max. 244 bytes per DP-Slave)
Output data		Max. 8192 bytes (Max. 244 bytes per DP-Slave)	
Number of writes to flash ROM		Max. 100000 times	
No. of occupied I/O points		32 (I/O assignment: 32 intelligent points)	
Internal current consumption (5 V DC)		0.55 A	
Weight		0.14 kg	

Tab. 3-1: Performance specifications

^① The transmission speed is controlled within ± 0.2 %. (Compliant with IEC 61158-2)

Transmission distance

Transmission speed	Transmission distance per segment	Max. transmission distance per network when three repeaters are used ^①
9.6 kbps	1200 m	4800 m
19.2 kbps		
93.75 kbps		
187.5 kbps	1000 m	4000 m
500 kbps	400 m	1600 m
1.5 Mbps	200 m	800 m
3 Mbps	100 m	400 m
6 Mbps		
12 Mbps		

Tab. 3-2: *Transmission distance*

- ① The max. transmission distance in the table above is based on the case where 3 repeaters are used. The calculation formula for the transmission distance extended using a repeater(s) is:
 Max. transmission distance [m/network] = (Number of repeaters + 1) × Transmission distance [m/segment]

3.3 Data and Signal Transfer

ME1PB1-L mounted to a LCPU

When the ME1PB1-L is mounted to a LCPU, the buffer memory and the X/Y signals are used for control of the module.

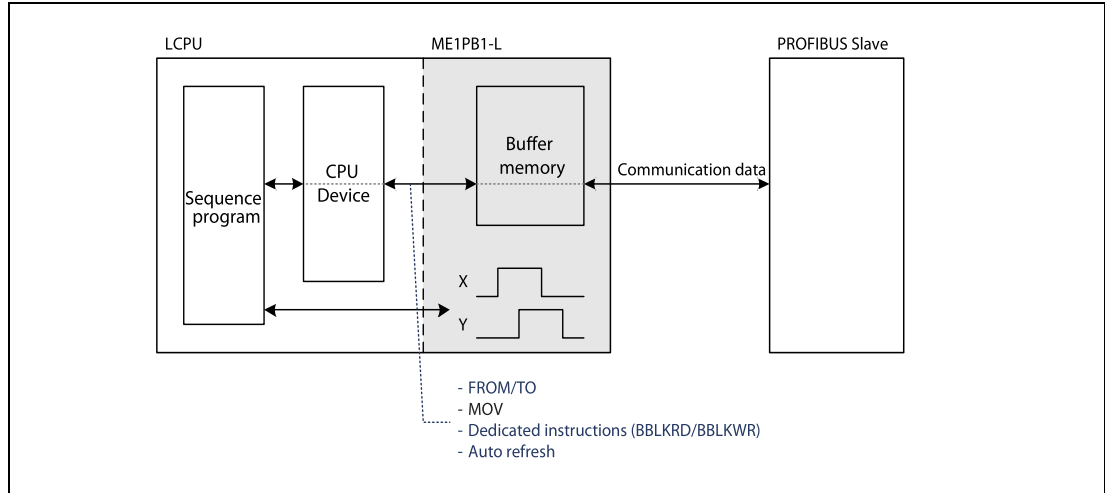

Fig. 3-1: Data flow when the ME1PB1-L is mounted to a LCPU

ME1PB1-L mounted to a CC-Link IE Field Network Head module

The ME1PB1-L doesn't support auto refresh with CC-Link IE Field head module. Therefore it is necessary to use dedicated instructions to access the buffer memory.

The X/Y signals can be accessed via RX/RX devices of the CC-Link IE Field network. Auto refresh for RX/RX is required in the network configuration setting in GX Works2.

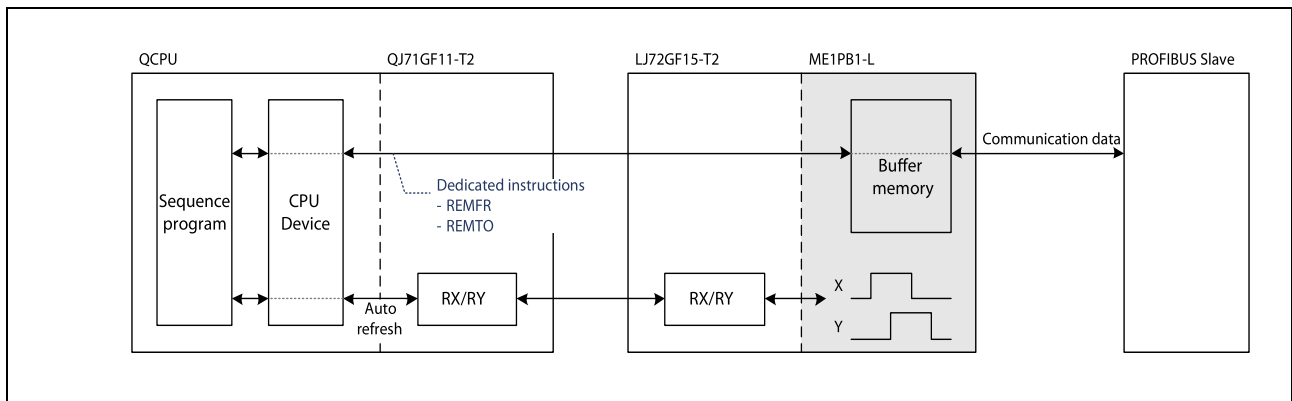

Fig. 3-2: Data flow when the ME1PB1-L is mounted to a CC-Link IE Field Network Head module

3.4 Function List

The following table gives an overview of the functions of the ME1PB1-L.

Function		Description	Reference (section)
PROFIBUS DPV0	I/O data exchange	Up to 125 DP-Slaves can be connected to a single ME1PB1-L, enabling the I/O data exchange of max. 8192 bytes.	4.1.1
	Acquisition of diagnostic and extended diagnostic information	Diagnostic or extended diagnostic information of an error occurred on a DP-Slaves during I/O data exchange can be easily acquired using the buffer memory and I/O signals.	4.1.2
	Global control function	By sending services (SYNC, UNSYNC, FREEZE, UNFREEZE) to each DP-Slave in a group, synchronous control of DP-Slave I/O data is available.	4.1.3
PROFIBUS DPV1	Acyclic communication with DP-Slaves	This function allows data reading/writing to DP-Slaves at any specific timing independently of I/O data exchange.	4.2.1
	Alarm acquisition	This function enables acquisition of up to 8 alarms or status information data that have been generated on any DP-Slave.	4.2.2
PROFIBUS DPV2	Time control over DP-Slaves	This function allows the ME1PB1-L to operate as the time master and set the time of each DP-Slave.	4.3.1
Data swap function		This function swaps the upper and lower bytes in word units when I/O data is sent and received.	4.4
Data consistency function		When I/O data from DP-Slaves are read from or written to the buffer memory, this function prevents the I/O data from being separated and incorrectly mixed. The data consistency function can be set by <ul style="list-style-type: none"> • Automatic refresh setting (Intelligent function utility) • Dedicated instructions (BBLKRD, BBLKWR) 	4.5
Output status setting for the case of a CPU stop error		This function sets whether to stop or continue I/O data exchange with DP-Slaves when a CPU stop error occurs on a MELSEC-L series CPU or CC-Link IE station where the ME1PB1-L is mounted.	4.6
Temporary slave reservation function		Without modifying the slave parameter in the intelligent function utility, this function allows the DP-Slave type to be changed to "Reserved station" temporarily.	4.7
Mode change function		It is possible to change the operation mode of the ME1PB1-L through the intelligent function utility or sequence program. The following modes are available: <ul style="list-style-type: none"> • Parameter setting mode (mode 1) • Self-diagnostics mode (mode 2) • Communication mode (mode 3) • Flash ROM clear mode (modes 9 → F → A) 	4.8
			9.5

Tab. 3-3: Functions of the ME1PB1-L

3.5 I/O-Signals for the PLC-CPU

3.5.1 List of I/O Signals

Note that the I/O numbers (X/Y) shown in this section and thereafter depend on the mounting position resp. on the start I/O number or head address of the ME1PB1-L. This head address has to be added to the shown I/O numbers.

For example, if the ME1PB1-L occupies the range from X/Y040 to Y/X05F the head address is X/Y040. However the least significant digit is omitted and the head address "n" in this case reads as "4". The "data exchange start completed signal" input (Xn0) will be X40 and the "operation mode signal" will be X50.

Signal Direction: ME1PB1-L → CPU module		Signal Direction: CPU module → ME1PB1-L	
Device no. (Input)	Signal name	Device no. (Output)	Signal name
Xn0	Data exchange start completed signal	Yn0	Data exchange start request signal
Xn1	Diagnostic information detection signal	Yn1	Diagnostic information detection reset request signal
Xn2	Diagnostic information area cleared signal	Yn2	Diagnostic information area clear request signal
Xn3	Use prohibited	Yn3	Use prohibited
Xn4	Global control completed signal	Yn4	Global control request signal
Xn5	Global control failed signal	Yn5	Use prohibited
Xn6	Extended diagnostic information read response signal	Yn6	Extended diagnostic information read request signal
Xn7	Use prohibited	Yn7	Use prohibited
Xn8		Yn8	
Xn9		Yn9	
XnA		YnA	
XnB		YnB	
XnC	Data consistency requesting signal	YnC	Data consistency start request signal
XnD	Use prohibited	YnD	Restart request signal
XnE		YnE	Use prohibited
XnF		YnF	
X(n+1)0	Operation mode signal	Y(n+1)0	
X(n+1)1	Operation mode change completed signal	Y(n+1)1	Operation mode change request signal
X(n+1)2	Use prohibited	Y(n+1)2	Use prohibited
X(n+1)3		Y(n+1)3	
X(n+1)4		Y(n+1)4	
X(n+1)5		Y(n+1)5	
X(n+1)6		Y(n+1)6	
X(n+1)7		Y(n+1)7	
X(n+1)8	Alarm read response signal	Y(n+1)8	Alarm read request signal
X(n+1)9	Time control start response signal	Y(n+1)9	Time control start request signal
X(n+1)A	Use prohibited	Y(n+1)A	Use prohibited
X(n+1)B	Communication READY signal	Y(n+1)B	
X(n+1)C	Use prohibited	Y(n+1)C	
X(n+1)D	Module READY signal	Y(n+1)D	
X(n+1)E	Use prohibited	Y(n+1)E	
X(n+1)F	Watchdog timer error signal	Y(n+1)F	

Tab. 3-4: I/O signals of the ME1PB1-L

NOTE

Among the I/O signals for the MELSEC-L series CPU, do not output (turn ON) the signals indicated as "Use prohibited."

If any of the "Use prohibited" signals is output, the programmable controller system may malfunction.

3.5.2 Details of I/O Signals

Data exchange start request signal (Yn0), data exchange start completed signal (Xn0)

- Turn ON the Data exchange start request signal (Yn0) to start I/O data exchange.
- When I/O data exchange is started after turning ON the Data exchange start request signal (Yn0), the Data exchange start completed signal (Xn0) turns ON.

The Data exchange start completed signal (Xn0) turns OFF in any of the following cases:

- When the Data exchange start request signal (Yn0) is turned OFF.
- When an error causing stop of I/O data exchange occurs.
- When parameters are currently being written to the ME1PB1-L from the configuration software.
- When the operation mode of the ME1PB1-L has been changed.
- When a communication error has occurred on a DP-Slave. (Only when the master parameter "Error action flag" is checked)

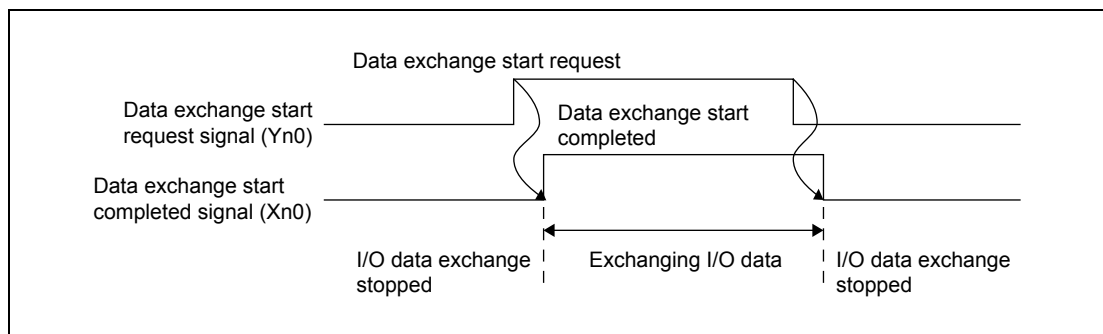

Fig. 3-3: Data exchange start request signal (Yn0), Data exchange start completed signal (Xn0)

- Use these signals as interlock signals when reading/writing I/O data.
- Write the initial values of the output data to the buffer memory before turning ON the Data exchange start request signal (Yn0).
- Turning OFF the Data exchange start request signal (Yn0) clears the information in the following areas.

- Slave status area (Normal communication detection) (Un\G23040 to Un\G23047)
- Slave status area (Diagnostic information detection) (Un\G23056 to Un\G23064)

The information in the other buffer memory areas is held.

Diagnostic information detection reset request signal (Yn1), Diagnostic information detection signal (Xn1)

- The Diagnostic information detection signal (Xn1) turns ON when a communication error is detected after the time preset in Diagnostic information non-notification time setting area (Un\G2084) has elapsed.

The following processing is performed at the same time that the Diagnostic information detection signal (Xn1) turns ON:

- The R ERR. LED turns ON.
The diagnostic information is stored in the Diagnostic information area (for mode 3) (Un\G23072 to Un\G23321).
- The extended diagnostic information is stored in the Extended diagnostic information area (for mode 3) (Un\G23328 to Un\G23454).
- The corresponding bit in the Slave status area (Diagnostic information detection) (Un\G23056 to Un\G23064) of the station that sent the diagnostic information turns ON.
- The error information of the ME1PB1-L is stored in the Local station error information area (Un\G23071).

- Turning ON the Diagnostic information detection reset request signal (Yn1) turns OFF the Diagnostic information detection signal (Xn1).

The following processing is performed at the same time that the Diagnostic information detection signal (Xn1) turns OFF:

- The R ERR. LED turns OFF.
- The corresponding bit in the slave status area (Diagnostic information detection) (Un\G23056 to Un\G23064) of the station that sent the diagnostic information turns ON.

- When new diagnostics information is generated while the Diagnostic information detection reset request signal (Yn1) is ON, the behavior is as follows:

- The Diagnostic information detection signal (Xn1) does not turn ON.
- The R ERR. LED does not turn ON.
- The corresponding bit in the Slave status area (Diagnostic information detection) (Un\G23056 to Un\G23064) of the station that sent the diagnostic information does not turn ON.

- After the Diagnostic information detection signal (Xn1) turns OFF, take actions for the error cause and turn OFF the Diagnostic information detection reset request signal (Yn1).

- After the Diagnostic information detection signal (Xn1) is turned OFF, the ME1PB1-L checks for diagnostic information again.

If any diagnostic information has been generated, the Diagnostic information detection signal (Xn1) turns ON, and processing as described on top of this page is performed.

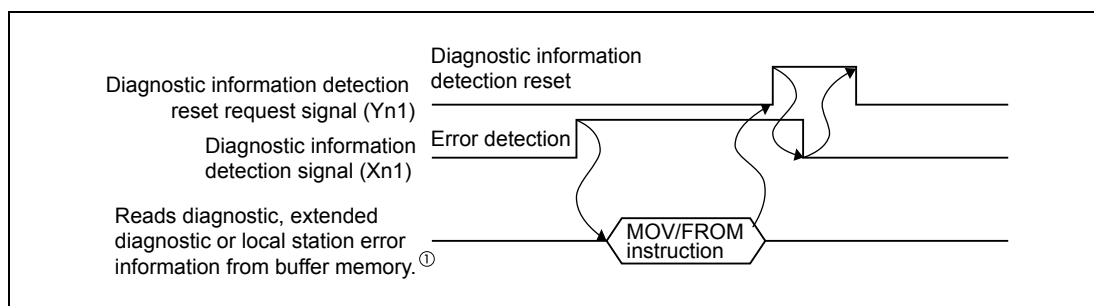

Fig. 3-4: Diagnostic information detection reset request signal (Yn1), Diagnostic information detection signal (Xn1)

- ① – Diagnostic information area (for mode 3) (Un\G23072 to Un\G23321)
 – Extended diagnostic information area (for mode 3) (Un\G23328 to Un\G23454)
 – Local station error information area (Un\G23071)

NOTE

Turning ON the Diagnostic information detection reset request signal (Yn1) does not clear the information shown below.

- Diagnostic information area (for mode 3) (Un\G23072 to Un\G23321)
- Extended diagnostic information area (for mode 3) (Un\G23328 to Un\G23454)
- Local station error information area (Un\G23071)

To clear the information in this areas, turn ON the Diagnostic information area clear request signal (Yn2).

Diagnostic information area clear request signal (Yn2), Diagnostic information area cleared signal (Xn2)

- Turn ON the Diagnostic information area clear request signal (Yn2) when clearing the following information:
 - Diagnostic information area (for mode 3) (Un\G23072 to Un\G23321)
 - Extended diagnostic information area (for mode 3) (Un\G23328 to Un\G23454)
 - Local station error information area (Un\G23071)
- When the Diagnostic information area clear request signal (Yn2) is turned ON, and the processing as described above is completed, the Diagnostic information area cleared signal (Xn2) turns ON.
- When new diagnostics information is generated while the Diagnostic information area clear request signal (Yn2) is ON, the following information stays cleared. (No diagnostic, extended diagnostic or local station error information is stored.)
 - Diagnostic information area (for mode 3) (Un\G23072 to Un\G23321)
 - Extended diagnostic information area (for mode 3) (Un\G23328 to Un\G23454)
 - Local station error information area (Un\G23071)
- After the Diagnostic information area cleared signal (Xn2) has turned ON, turn OFF the Diagnostic information area clear request signal (Yn2).
- Taking corrective actions for the error and turning OFF the Diagnostic information area clear request signal (Yn2) turns OFF the Diagnostic information area cleared signal (Xn2).
- After the Diagnostic information area clear request signal (Yn2) is turned OFF, the ME1PB1-L checks for diagnostic information again. If any diagnostic information has been generated, the diagnostic information, extended diagnostic information and/or local station error information is stored in the buffer memory.

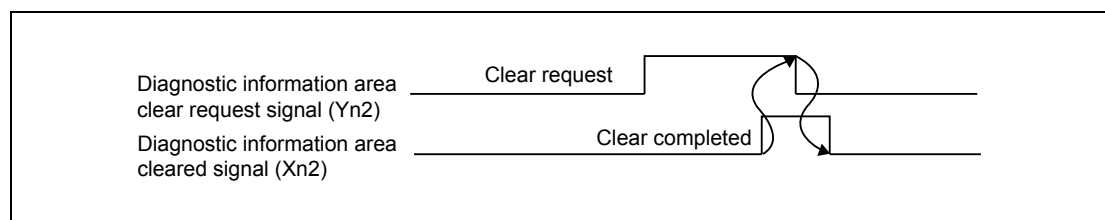

Fig. 3-5: Diagnostic information area clear request signal (Yn2), Diagnostic Information area cleared signal (Xn2)

Global control request signal (Yn4), Global control completed signal (Xn4)

- Turn ON the Global control request signal (Yn4) when executing the global control.
- When the Global control request signal (Yn4) is turned ON, and global control processing is completed, the Global control completed signal (Xn4) turns ON.
- After the Global control completed signal (Xn4) has turned ON, turn OFF the Global control request signal (Yn4).
- Turning OFF the Global control request signal (Yn4) turns OFF the Global control completed signal (Xn4).
- Turn ON the Global control request signal (Yn4) while the Data exchange start completed signal (Xn0) is ON.

If the Global control request signal (Yn4) is turned ON with the Data exchange start completed signal (Xn0) OFF, both of the Global control completed signal (Xn4) and Global control failed signal (Xn5) turn ON.

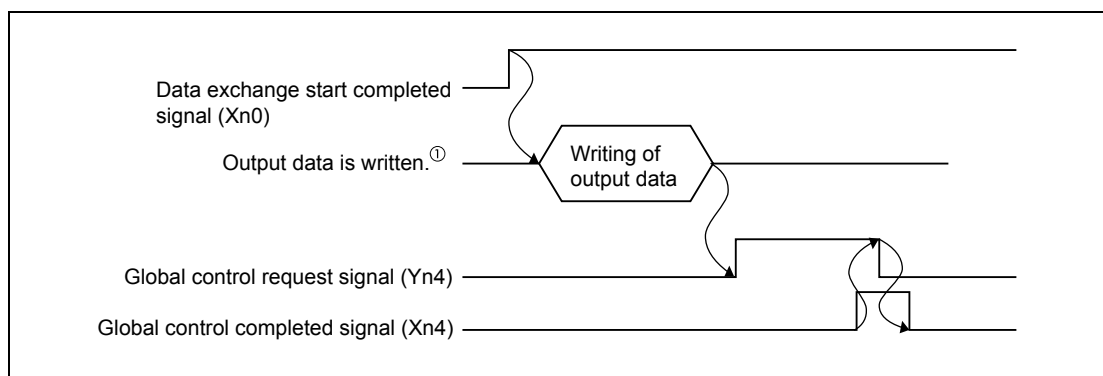

Fig. 3-6: Global control request signal (Yn4), Global control completed signal (Xn4)

① Output data area (for mode 3) (Un\G14336 to Un\G18431)

Global control failed signal (Xn5)

- If the Global control request signal (Yn4) is turned ON while the Data exchange start completed signal (Xn0) is OFF, both the Global control completed signal (Xn4) and Global control failed signal (Xn5) turn ON.
- The ON status of the Global control failed signal (Xn5) means that the global control has failed. Remedy the cause of the error, and execute the global control again.
- Turning OFF the Global control request signal (Yn4) turns OFF the Global control failed signal (Xn5).

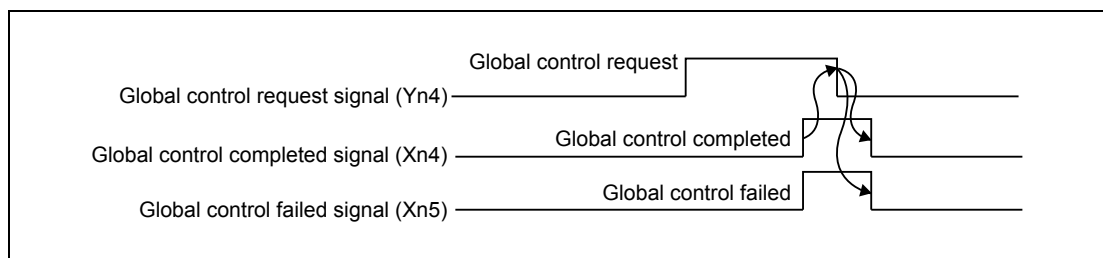

Fig. 3-7: Global control failed signal (Xn5)

For details off the global control, refer to section 4.1.3.

Extended diagnostic information read request signal (Yn6), Extended diagnostic information read response signal (Xn6)

- Turn ON the Extended diagnostic information read request signal (Yn6) when reading the extended diagnostic information of the FDL address specified in the Extended diagnostic information read request area (Un\G23456).
- Turning ON the Extended diagnostic information read request signal (Yn6) clears the information of the Extended diagnostic information read response area (Un\G23457 to Un\G23583).
- When the Extended diagnostic information read request signal (Yn6) is turned ON, and reading of the extended diagnostic information of the specified FDL address is completed, the Extended diagnostic information read response signal (Xn6) turns ON.
- After the Extended diagnostic information read response signal (Xn6) has turned ON, turn OFF the Extended diagnostic information read request signal (Yn6).
- Turning OFF the Extended diagnostic information read request signal (Yn6) turns OFF the Extended diagnostic information read response signal (Xn6).

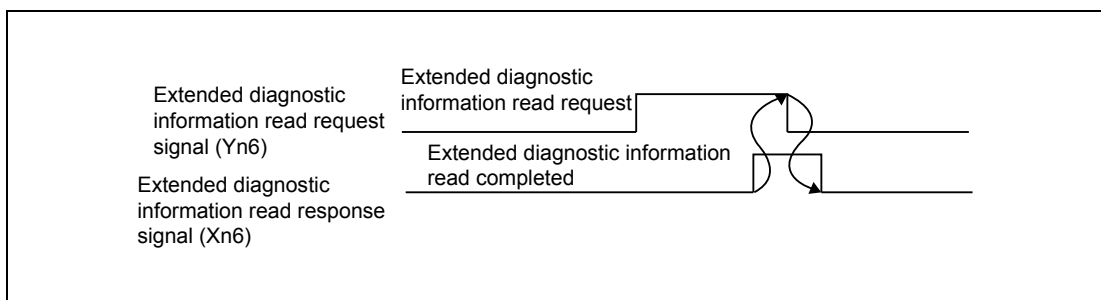

Fig. 3-8: Extended diagnostic information read request signal (Yn6), Extended diagnostic information read response signal (Xn6)

For details on acquisition of extended diagnostics information, refer to section 4.1.2.

Data consistency start request signal (YnC), Data consistency requesting signal (XnC)

- The Data consistency start request signal (YnC) is used to enable the data consistency function for dedicated instructions.

ON/OFF status	Description
ON	Enables read/write executed by dedicated instructions. Turning ON the Data consistency start request signal (YnC) turns ON the Data consistency requesting signal (XnC).
OFF	Disables read/write executed by dedicated instructions. Turning OFF the Data consistency start request signal (YnC) turns OFF the Data consistency requesting signal (XnC), and the BBLKRD and BBLKWR instructions are not executed.

Tab. 3-5: Data consistency start request signal (YnC)

- Use the Data consistency start request signal (YnC) and Data consistency requesting signal (XnC) as interlock signals for dedicated instructions.
- When using the data consistency function (automatic refresh) by the intelligent function utility, turn OFF the Data consistency start request signal (YnC).

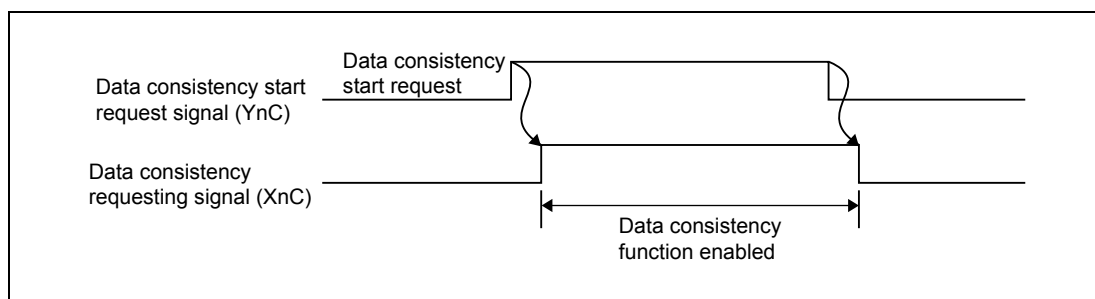

Fig. 3-9: Data consistency start request signal (YnC), Data consistency requesting signal (XnC)

Restart request signal (YnD)

- If the ME1PB1-L has gone down for some reason (In this case the ERR. LED is ON and the module READY signal (X(n+1)D) is OFF), turning the Restart request signal (YnD) OFF, ON and OFF again restarts the ME1PB1-L.
- After the ME1PB1-L is restarted, the status is the same as the one after:
 - The programmable controller is turned OFF and back ON again.
 - The MELSEC-L series CPU is reset.

Operation mode signal (X(n+1)0)

This signal indicates whether or not the current operation mode is Communication mode (mode 3).

ON/OFF status	Description
ON	Other than Communication mode (mode 3)
OFF	Communication mode (mode 3)

Tab. 3-6: Operation mode signal (X(n+1)0)

Operation mode change request signal (Y(n+1)1), Operation mode change completed signal (X(n+1)1)

- Turn ON the Operation mode change request signal (Y(n+1)1) when changing the operation mode to the one set in the Operation mode change request area (Un\G2255). The operation mode can be changed without resetting the PLC CPU.
- Turning ON the Operation mode change request signal (Y(n+1)1) clears the information of the Operation mode change result area (Un\G2256).
- The Operation mode change completed signal (X(n+1)1) turns ON when the operation mode is changed, and the result of the change is stored to the Operation mode change result area (Un\G2256).
- Make sure that A300H (Normally completed) is stored in the Operation mode change result area (Un\G2256), and turn OFF the Operation mode change request signal (Y(n+1)1).
- Turning OFF the Operation mode change request signal (Y(n+1)1) turns OFF the Operation mode change completed signal (X(n+1)1).

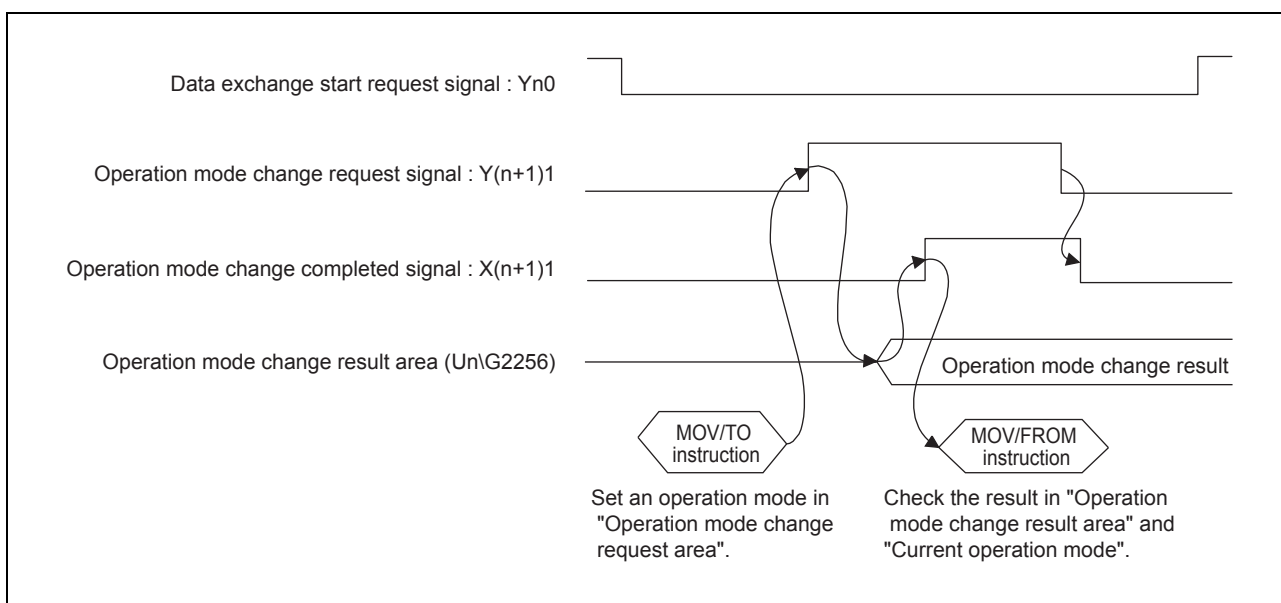

Fig. 3-10: Operation mode change request signal (Y(n+1)1), Operation mode change completed signal (X(n+1)1)

For a description of the operation mode change function, refer to section 4.8.

NOTE

Do not turn the power OFF or reset the MELSEC-L series CPU during the operation mode registration to the flash ROM by turning ON the Operation mode change request signal (Y(n+1)1).

Turn the power OFF or reset the MELSEC-L series CPU after the Operation mode change completed signal (X(n+1)1) has turned ON. If the power is turned OFF or the MELSEC-L series CPU is reset by mistake, register the operation mode to the flash ROM again.

Alarm read request signal (Y(n+1)8), Alarm read response signal (X(n+1)8)

- Turn ON the Alarm read request signal (Y(n+1)8) when reading alarms on the specified DP-Slave according to the information set in the Alarm request area (Un\G26432 to Un\G26434).
- Turning ON the Alarm read request signal (Y(n+1)8) clears the information in the Alarm response area (Un\G26446 to Un\G26768). Note, however, that the information in the following areas are not cleared when the alarm ACK request (request code: 1501H) is executed:

Buffer memory address DEC (HEX)	Description
26449 to 26484 (6751H to 6774H)	Area to which alarm data of alarm data No.1 is stored
26489 to 26524 (6779H to 679CH)	Area to which alarm data of alarm data No.2 is stored
26529 to 26564 (67A1H to 67C4H)	Area to which alarm data of alarm data No.3 is stored
26569 to 26604 (67C9H to 67ECH)	Area to which alarm data of alarm data No.4 is stored
26609 to 26644 (67F1H to 6814H)	Area to which alarm data of alarm data No.5 is stored
26649 to 26684 (6819H to 683CH)	Area to which alarm data of alarm data No.6 is stored
26689 to 26724 (6841H to 6864H)	Area to which alarm data of alarm data No.7 is stored
26729 to 26764 (6869H to 688CH)	Area to which alarm data of alarm data No.8 is stored

Tab. 3-7: Areas not cleared at alarm ACK request execution

- The Alarm read response signal (X(n+1)8) turns ON when alarms on the specified DP-Slave are read, and the execution result is stored to the Alarm response area (Un\G26446 to Un\G26768).
- Read the alarm information from the Alarm response area (Un\G26446 to Un\G26768), and turn OFF the Alarm read request signal (Y(n+1)8).
- Turning OFF the Alarm read request signal (Y(n+1)8) turns OFF the Alarm read response signal (X(n+1)8).

For details of the acquisition of alarms, refer to section 4.2.2.

Time control start request signal (Y(n+1)9), Time control start response signal (X(n+1)9)

- Turn ON the Time control start request signal (Y(n+1)9) when executing the time control over DP-Slaves according to the information set in the Time control setting request area (Un\G26784 to Un\G26792).
- Turning ON the Time control start request signal (Y(n+1)9) clears the information in the Time control setting response area (Un\G26800 to Un\G26812).
- The Time control start response signal (X(n+1)9) turns ON when the time control over DP-Slaves is executed, and the execution result is stored in the Time control setting response area (Un\G26800 to Un\G26812).
- Read the execution result from the Time control setting response area (Un\G26800 to Un\G26812), and turn OFF the Time control start request signal (Y(n+1)9).
- Turning OFF the Time control start request signal (Y(n+1)9) turns OFF the Time control start response signal (X(n+1)9).

For details off time control over DP-Slaves, refer to section 4.1.3.

Communication READY signal (X(n+1)B)

- The Communication READY signal (X(n+1)B) turns ON when the Module READY signal (X(n+1)D) turns ON and I/O data exchange is ready to be started. (The signal turns ON only in the Communication mode (mode 3).)
- The signal turns OFF when an error disabling I/O data exchange occurs on the ME1PB1-L.
- Use the signal as an interlock signal for when turning ON the Data exchange start request signal (Yn0).

Module READY signal (X(n+1)D)

- This signal turns ON when the ME1PB1-L is started up. (This signal turns ON regardless of the operation mode.)
- While the ME1PB1-L is not ready, this signal is OFF.

Watchdog timer error signal (X(n+1)F)

- This signal turns ON when a watchdog timer error occurs on the ME1PB1-L.
- The Watchdog timer error signal (X(n+1)F) does not turn OFF until:
 - The programmable controller is turned OFF and back ON again, or
 - The MELSEC-L series CPU is reset.

3.6 Buffer Memory

The ME1PB1-L has a memory range assigned as a buffer for temporary storage of data, such as communication related data or error information. The PLC CPU can access this buffer and both read the stored values from it and write new values to it which the module can then process.

Each buffer memory address consists of 16 bits.

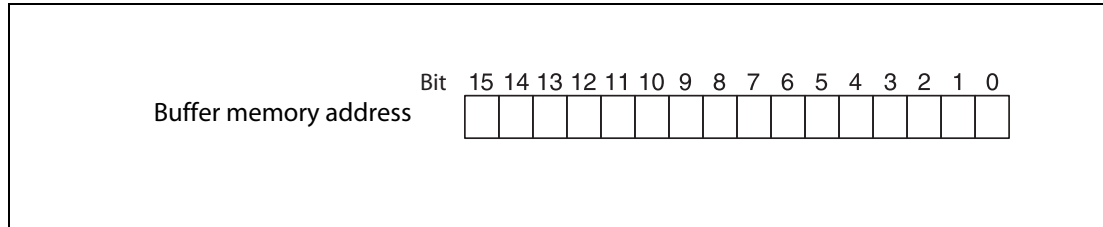

Fig. 3-11: Assignments of bits to a buffer memory address

NOTE

Do not write data in the "system areas" of the buffer memory. If data is written to any of the system areas, the PLC system may not be operated properly. Some of the user areas contain partially system areas. Care must be taken when reading/writing to the buffer memory. Also, do not write data (e.g. in a sequence program) to the buffer memory area where writing is disabled. Doing so may cause malfunction.

The "Default" value indicated in the following tables is the initial value set after the power is turned on or the PLC CPU is reset.

Instructions for data exchange with the buffer memory

Communication between the PLC CPU and the buffer memory of special function modules is performed with FROM and TO instructions. The buffer memory of a special function module can also be accessed directly, e. g. with a MOV instruction.

Format of the device address: Un\Gn

- Un: Head address of the special function module
- Gn: Buffer memory address (decimal)

For example the device address U3\G11 designates the buffer memory address 11 in the special function module with the head address 3 (X/Y30 to X/Y3F).

In this User's Manual the latter form of addressing is used widely.

For full documentation of all the instructions used with examples please refer to the Programming Manual for the MELSEC System Q and the MELSEC-L series.

3.6.1 Buffer memory list

Address DEC (HEX)	Name	Description	Default value	Read/ Write ^①	Reference (section)
0 to 2079 (0H to 81FH)	System area (Use prohibited)	—	—	—	—
2080 (820H)	Diagnostic information invalid setting area	Values for masking (invalidating) diagnostic information from DP-Slaves are set in this area.	02B9H	R/W	3.6.6
2081 (821H)	Global control area	The global control function to be executed is set in this area.	0	R/W	3.6.9
2082 to 2083 (822H to 823H)	System area (Use prohibited)	—	—	—	—
2084 (824H)	Diagnostic information non-notification time setting area	This area is used to set the time during which no diagnostic information is notified after communication start.	20	R/W	3.6.6
2085 (825H)	Current diagnostic information non-notification time area	This area stores the time (remaining time) during which no diagnostic information is notified after communication start.	0	R	
2086 to 2253 (826H to 8CDH)	System area (Use prohibited)	—	—	—	—
2254 (8CEH)	Current operation mode area	This area stores data of the currently operating mode.	0001H	R	3.6.2
2255 (8CFH)	Operation mode change request area	When executing the operation mode change request, a desired operation mode is set in this area.	FFFEH	R/W	3.6.3
2256 (8D0H)	Operation mode change result area	This area stores the execution result of the operation mode change request.	0	R	
2257 (8D1H)	Local FDL address display area	This area stores the FDL address of the local station.	FFFFH	R	3.6.2
2258 (8D2H)	Offline test status area	This area stores the details or result of the self-diagnostic test.	0	R	
2259 (8D3H)	Flash ROM storage mode	This area stores the operation mode currently stored in the flash ROM.	FFFFH	R	
2260 to 2271 (8D4H to 8DFH)	System area (Use prohibited)	—	—	—	—
2272 (8E0H)	Current bus cycle time	This area stores the current bus cycle time.	0	R	3.6.8
2273 (8E1H)	Min. bus cycle time	This area stores the minimum value of the bus cycle time.	0	R	
2274 (8E2H)	Max. bus cycle time	This area stores the maximum value of the bus cycle time.	0	R	
2275 to 6143 (8E3H to 17FFH)	System area (Use prohibited)	—	—	—	—
6144 to 10239 (1800H to 27FFH)	Input data area (for mode 3)	In Communication mode (mode 3), this area is used to store the input data received from each DP-Slave.	0	R	3.6.4
10240 to 14335 (2800H to 37FFH)	System area (Use prohibited)	—	—	—	—
14336 to 18431 (3800H to 47FFH)	Output data area (for mode 3)	In Communication mode (mode 3), this area is used to set the output data to be sent to each DP-Slave.	0	R/W	3.6.4
18432 to 22527 (4800H to 57FFH)	System area (Use prohibited)	—	—	—	—
22528 to 22777 (5800H to 58F9H)	Address information area (for mode 3)	In Communication mode (mode 3), this area is used to store the FDL address of each DP-Slave and I/O data length.	FFFFH	R	3.6.4
22778 to 22783 (58FAH to 58FFH)	System area (Use prohibited)	—	—	—	—

Tab. 3-8: Buffer memory list (1)

Address DEC (HEX)	Name	Description	Default value	Read/ Write ①	Reference (section)
22784 to 22908 (5900H to 597C _H)	Input data start address area (for mode 3)	In Communication mode (mode 3), this area is used to store the start address (buffer memory address) of the input data of each DP-Slave.	0	R	3.6.4
22909 to 22911 (597D _H to 597F _H)	System area (Use prohibited)	—	—	—	—
22912 to 23036 (5980 _H to 59FC _H)	Output data start address area (for mode 3)	In Communication mode (mode 3), this area is used to store the start address (buffer memory address) of the output data of each DP-Slave.	0	R	3.6.4
23037 to 23039 (59FD _H to 59FF _H)	System area (Use prohibited)	—	—	—	—
23040 to 23047 (5A00 _H to 5A07 _H)	Slave status area (Normal communication detection)	This area stores the communication status of each DP-Slave.	0	R	3.6.5
23048 to 23055 (5A08 _H to 5A0F _H)	Slave status area (Reserved station setting status)	This area stores the reserved or temporary slave reservation setting of each DP-Slave.	0	R	
23056 to 23064 (5A10 _H to 5A18 _H)	Slave status area (Diagnostic information detection)	This area stores the diagnostic information generation status of each DP-Slave.	0	R	
23065 to 23070 (5A19 _H to 5A1E _H)	System area (Use prohibited)	—	—	—	—
23071 (5A1F _H)	Local station error information area	This area stores the error information of the local station (ME1PB1-L).	0	R	3.6.2
23072 to 23321 (5A20 _H to 5B19 _H)	Diagnostic information area (for mode 3)	In Communication mode (mode 3), this area is used to store the diagnostic information of the error occurred on each DP-Slave during communication.	0	R	3.6.6
23322 to 23327 (5B1A _H to 5B1F _H)	System area (Use prohibited)	—	—	—	—
23328 to 23454 (5B20 _H to 5B9E _H)	Extended diagnostic information area (for mode 3)	In Communication mode (mode 3), this area is used to store the extended diagnostic information of the error occurred on each DP-Slave during communication.	0	R	3.6.6
23455 (5B9F _H)	System area (Use prohibited)	—	—	—	—
23456 (5BA0 _H)	Extended diagnostic information read request area	This area is used to set the FDL address of the station from which the extended diagnostic information is read.	FFFF _H	R/W	3.6.7
23457 to 23583 (5BA1 _H to 5C1F _H)	Extended diagnostic information read response area	This area stores the execution result of the extended diagnostic information read request.	0	R	
23584 to 23591 (5C20 _H to 5C27 _H)	Parameter setting status area (Active station)	This area stores data of the DP-Slaves that are set to Normal DP-Slave by the slave parameters.	0	R	3.6.5
23592 to 23599 (5C28 _H to 5C2F _H)	Parameter setting status area (Reserved station)	This area stores data of the DP-Slaves that are set to Reserved station by the slave parameters.	0	R	
23600 to 23607 (5C30 _H to 5C37 _H)	Temporary slave reservation status area	This area stores data of the DP-Slaves that are set to Temporary slave reservation by the temporary slave reservation function.	0	R	
23608 to 23615 (5C38 _H to 5C3F _H)	Temporary slave reservation request area	This area is used to set DP-Slaves to Temporary slave reservation using the temporary slave reservation function.	0	R/W	3.6.13
23616 to 23807 (5C40 _H to 5CFF _H)	System area (Use prohibited)	—	—	—	—
23808 (5D00 _H)	Acyclic communication request execution instruction area	This area is used to set which request is to be executed in acyclic communications.	0	R/W	3.6.10
23809 to 24832 (5D01 _H to 6100 _H)	Acyclic communication request area	This area is used to set the request data for acyclic communications.	0	R/W	
24833 to 25119 (6101 _H to 621F _H)	System area (Use prohibited)	—	—	—	—
25120 (6220 _H)	Acyclic communication request result area	This area stores the request acceptance status and execution completion status in acyclic communications.	0	R	3.6.10

Tab. 3-8: Buffer memory list (2)

Address DEC (HEX)	Name	Description	Default value	Read/ Write ①	Reference (section)
25121 to 26144 (6221 _H to 6620 _H)	Acyclic communication response area	This area stores the execution result of acyclic communication.	0	R	3.6.10
26145 to 26415 (6621 _H to 672F _H)	System area (Use prohibited)	—	—	—	—
26416 to 26424 (6730 _H to 6738 _H)	Slave status area (Alarm detection)	This area stores the alarm status of each DP-Slave.	0	R	3.6.5
26425 to 26431 (6739 _H to 673F _H)	System area (Use prohibited)	—	—	—	—
26432 to 26434 (6740 _H to 6742 _H)	Alarm request area	This area is used to set the request data for alarm acquisition.	0	R/W	3.6.11
26435 to 26445 (6743 _H to 674D _H)	System area (Use prohibited)	—	—	—	—
26446 to 26768 (674E _H to 6890 _H)	Alarm response area	This area stores the execution result of alarm acquisition.	0	R	3.6.11
26769 to 26783 (6891 _H to 689F _H)	System area (Use prohibited)	—	—	—	—
26784 to 26792 (68A0 _H to 68A8 _H)	Time control setting request area	This area is used to set the request data for time control.	0	R/W	3.6.12
26793 to 26799 (68A9 _H to 68AF _H)	System area (Use prohibited)	—	—	—	—
26800 to 26812 (68B0 _H to 68BC _H)	Time control setting response area	This area stores the execution result of time control.	0	R	3.6.12
26813 to 32767 (68BD _H to 7FFF _H)	System area (Use prohibited)	—	—	—	—

Tab. 3-8: Buffer memory list (3)

① This indicates whether or not read/write is possible from the sequence program.

R: Read only

R/W: Read/write executable

3.6.2 Local station information area

The information of the local station (ME1PB1-L) is stored in this area.

Local station error information area (Un\G23071)

This area stores the error information of the local station (ME1PB1-L).

Stored value	Description
0000H	Normal
Other than 0000H	Error (Error code (refer to section 9.4.6))

Tab. 3-9: Local station error information area (Un\G23071)

NOTE

The information in the Local station error information area (Un\G23071) is not cleared even if the problem occurred on the ME1PB1-L has been solved.

To clear the Local station error information area (Un\G23071), turn ON the Diagnostic information area clear request signal (Yn2).

Current operation mode area (Un\G2254)

This area stores the current operation mode value.

Stored value	Description
0001H	Parameter setting mode
0002H	Self-diagnostic mode
0003H	Communication mode (mode 3)
0009H	Flash ROM initialization mode
0101H	Parameter setting mode ^①
0103H	Communication mode (mode 3) ^①

Tab. 3-10: Current operation mode area (Un\G2254)

^① Operation mode currently registered to flash ROM

Flash ROM storage mode (Un\G2259)

This area stores the operation mode currently stored to flash ROM.

Stored value	Description
0101H	Parameter setting mode
0103H	Communication mode (mode 3)
FFFFH	Not registered (No operation mode has been registered to the flash ROM.)

Tab. 3-11: Flash ROM storage mode (Un\G2259)

Local FDL address display area (Un\G2257)

The FDL address of the local station is stored.

Stored value	Description
0000H to 007DH (0 to 125)	The FDL address of the local station
FFFFH	Parameter not set

Tab. 3-12: Local FDL address display area (Un\G2257)

Offline test status area (Un\G2258)

The self-diagnostics test details or test result is stored in this area.

For details on the self-diagnostics test, refer to section 5.4.

3.6.3 Operation mode change area

This area is used to change the operation mode of the local station (ME1PB1-L).

For changing the operation mode, refer to section 6.2.

Operation mode change request area (Un\G2255)

For execution of the operation mode change request, set a desired operation mode. (Initial value: FFFE_H). The initial value (FFFE_H) is used for malfunction prevention.

If the Operation mode change request signal (Y(n+)₁) is turned ON with the initial value stored in the Operation mode change request area (Un\G2255), E300_H is stored in the Operation mode change result area (Un\G2256) and the operation mode is not changed.

Set value	Description
0001H	The mode is changed to Parameter setting mode.
0002H	The mode is changed to Self-diagnostics mode.
0003H	The mode is changed to Communication mode (mode 3).
0009H	The mode is changed to Flash ROM initialization mode.
0101H	The mode is changed to Parameter setting mode. The Parameter setting mode is registered to the flash ROM at the same time as the operation mode change.
0103H	The mode is changed to Communication mode (mode 3). The Communication mode (mode 3) is registered to the flash ROM at the same time as the operation mode change.
FFFFH	The mode is changed to Parameter setting mode. The mode registered to the flash ROM is deleted at the same time as the operation mode change.

Tab. 3-13: Operation mode change request area (Un\G2255)

Operation mode change result area (Un\G2256)

This area stores the execution result of the operation mode change request.

Stored value	Description
A300H	Normally completed
Other than A300H	Failed (Error code (refer to section 9.4.2))

Tab. 3-14: Operation mode change result area (Un\G2256)

3.6.4 I/O data exchange area

This area is used for the I/O data exchange function.

NOTES

Data are assigned to the I/O data exchange area in the order of parameters set with the intelligent function utility (in the order of FDL addresses).

The actual order of assignment can be checked in Address information area (for mode 3) (Un\G22528 to Un\G22777) or in "Documentation of I/O-Mapping" of the intelligent function utility.

FDL Addr.	Name	Model
3	Slave_Nr_002	ST1H-PB
10	Slave_Nr_001	QJ71PB93D
32	Slave_Nr_003	AJ95TB32-16DT 8 DI / 8DO

Order of assignment

When parameters have been modified (deletion or addition of DP-Slave(s)) by the intelligent function utility, the buffer memory is reassigned.

After modifying parameters, review the sequence program.

If some DP-Slaves are expected to be connected to the network in the future, setting them as Reserved stations in the parameter setting eliminates the need to check the sequence program. (Refer to section 6.5)

Input data of a DP-Slave^①, which has failed in I/O data exchange, are not stored in the Input data area of the ME1PB1-L.

Data stored before the fault are held in the relevant Input data area for the DP-Slave.

^① DP-Slave corresponding to the bit that is turned OFF in the Slave status area (Normal communication detection) (Un\G23040 to Un\G23047)

Input data area (for mode 3) (Un\G6144 to Un\G10239)

When the operation mode is Communication mode (mode 3), input data from DP-Slaves are stored in this area.

- Data length setting

The data length (unit: byte) for each station is variable and assigned based on the slave parameter ("Slave Modules" window) set using the intelligent function utility.

For the DP-Slave that has a fixed data length, the slave parameter setting will be ignored.

- Data length range

The maximum data length per module is 244 bytes, and the total data length for all DP-Slaves can be set up to 8192 bytes.

When the data length is an odd number of bytes, 00H is stored to the final high byte. The input data of the next station is assigned starting from the next buffer memory address.

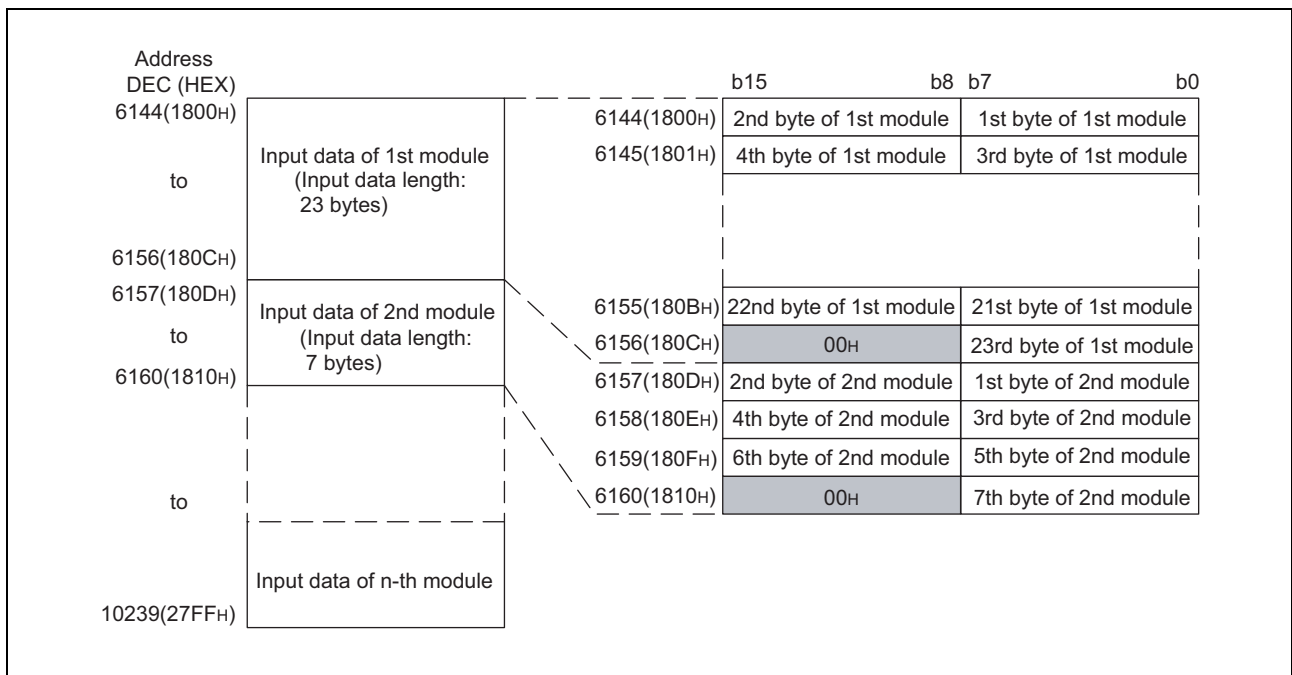
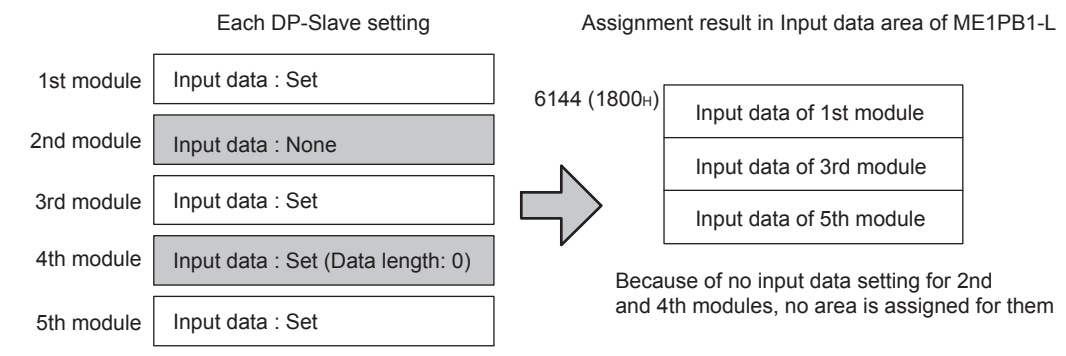

Fig. 3-12: Example of input data assignment (1st module: 23 bytes, 2nd module: 7 bytes)

NOTE

If a DP-Slave with no input data is assigned, its space in the input data area is taken over by the next station with input data, as shown below.



Output data area (for mode 3) (Un\G14336 to Un\G18431)

When the operation mode is Communication mode (mode 3), output data to DP-Slaves are set.

● Data length setting

The data length (unit: byte) for each station is variable and assigned based on the slave parameter ("Slave Modules" window) set using the intelligent function utility.

For the DP-Slave that has a fixed data length, the slave parameter setting will be ignored.

● Data length range

The maximum data length per module is 244 bytes, and the total data length for all DP-Slaves can be set up to 8192 bytes.

When the data length is an odd number of bytes, the final high byte is occupied. Set 00H to the final high byte.

The output data of the next station is assigned starting from the next buffer address.

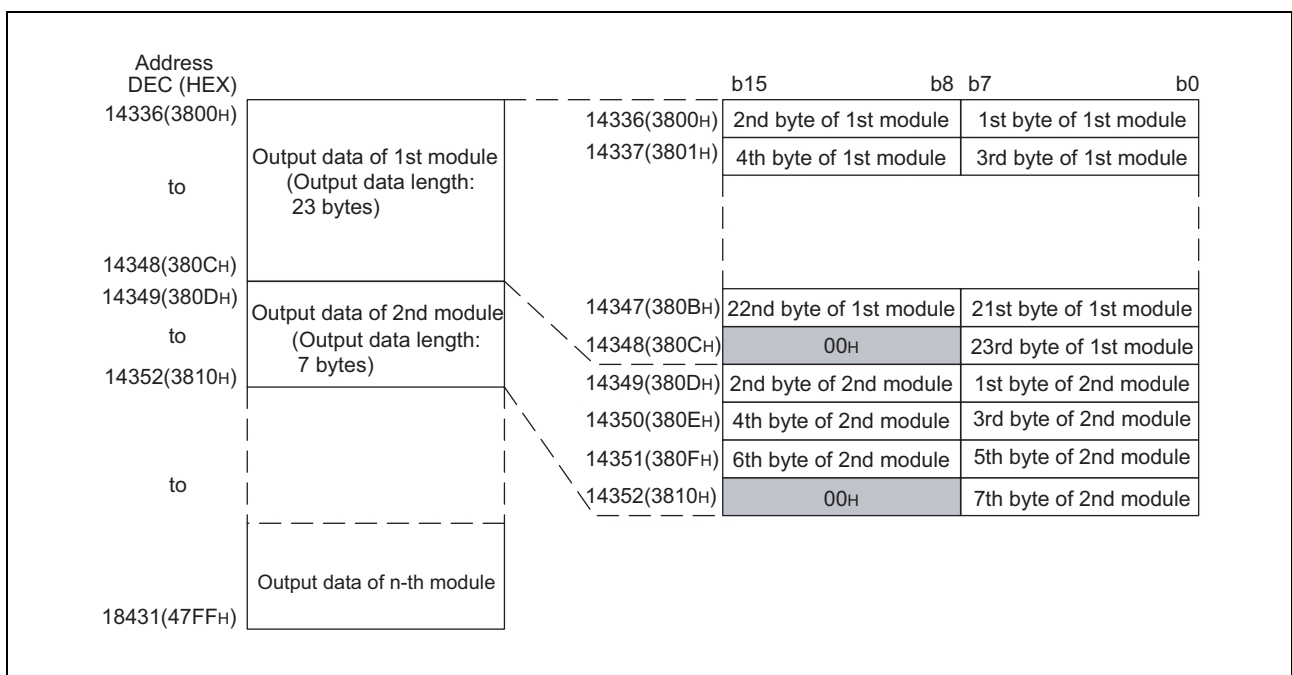
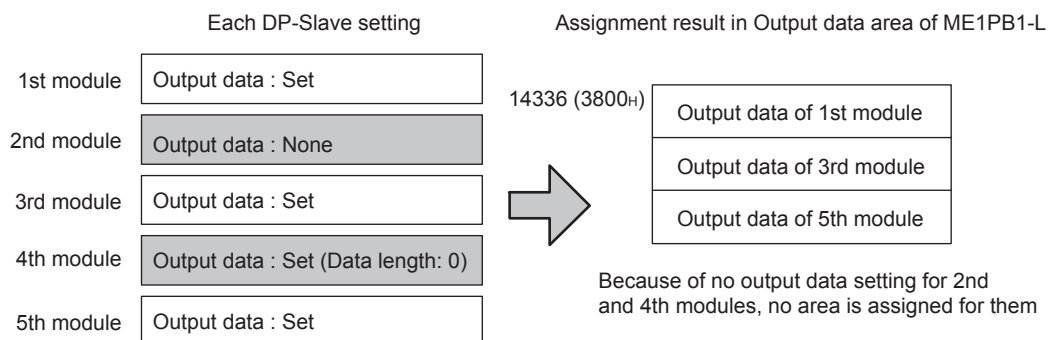

Fig. 3-13: Example of output data assignment (1st module: 23 bytes, 2nd module: 7 bytes)

NOTE

If a DP-Slave with no output data is assigned, its space in the output data area is taken over by the next station with output data, as shown below.



Address information area (for mode 3) (Un\G22528 to Un\G22777)

When the operation mode is Communication mode (mode 3), the FDL address and I/O data length of each DP-Slave are stored in this area.

Information of 125 modules is stored in the Address information area (for mode 3) in the same order for each module.

Information for reserved or temporary slave reservation is also stored.

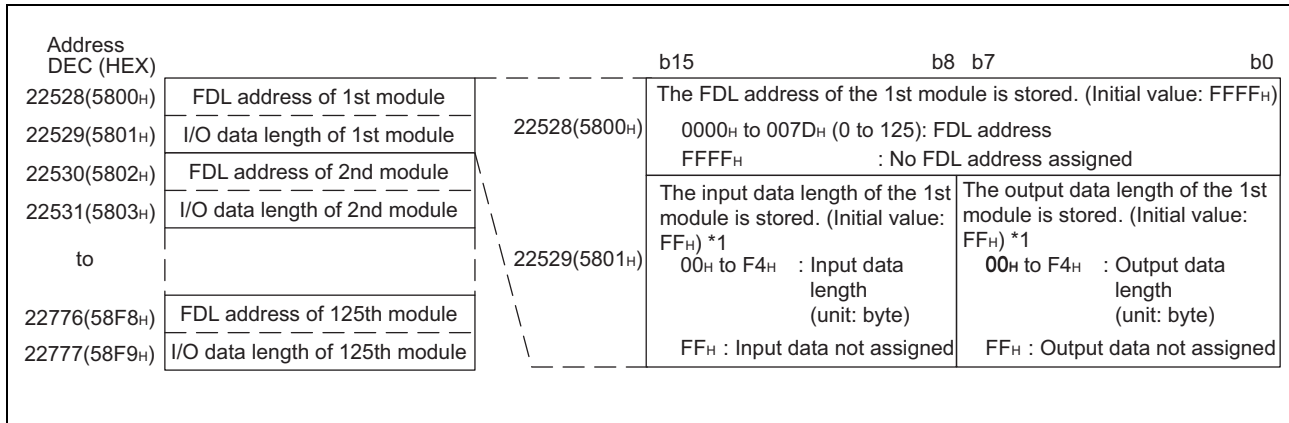

Fig. 3-14: Address information area (for mode 3) (Un\G22528 to Un\G22777)

- ① The difference between 00_H and FF_H is as follows:
 00_H means that input or output data are assigned with the data length set to 0.
 FF_H shows that assigned input or output data do **not** exist.

Input data start address area (for mode 3) (Un\G22784 to Un\G22908)

When the operation mode is Communication mode (mode 3), the start address (buffer memory address) for each DP-Slave's input data is stored in this area.

Creating a sequence program utilizing the Input data start address area (for mode 3) (Un\G22784 to Un\G22908) allows address specification of the Input data area without consideration of the input points for each DP-Slave.

Information of 125 modules is stored in the Input data start address area (for mode 3) in the same order for each module.

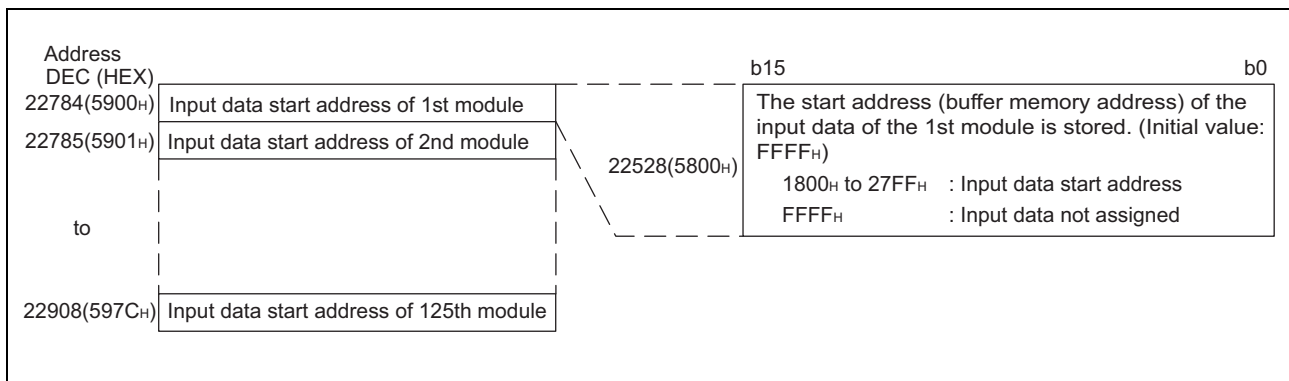

Fig. 3-15: Input data start address area (for mode 3) (Un\G22784 to Un\G22908)

Output data start address area (for mode 3) (Un\G22912 to Un\G23036)

When the operation mode is Communication mode (mode 3), the start address (buffer memory address) for each DP-Slave's output data is stored in this area.

Creating a sequence program utilizing the Output data start address area (for mode 3) (Un\G22912 to Un\G23036) allows address specification of the Output data area without consideration of the output points for each DP-Slave.

Information of 125 modules is stored in the Output data start address area (for mode 3) in the same order for each module.

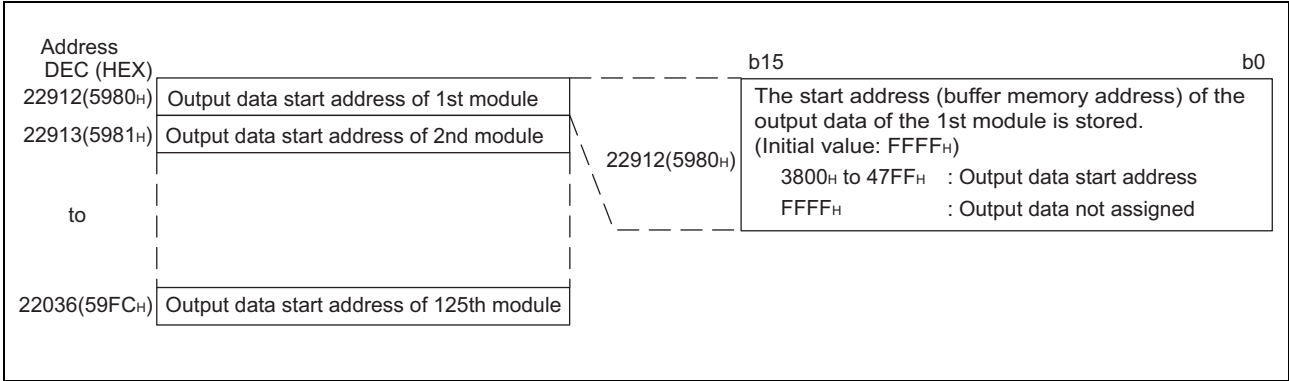

Fig. 3-16: Output data start address area (for mode 3) (Un\G22912 to Un\G23036)

3.6.5 Slave status area

This area stores the operation status of each DP-Slave.

NOTES

The corresponding bits of the Slave status area are assigned in order of the parameters set in the intelligent function utility (in order of the FDL address).

The actual order of assignment can be checked in the Address information area (for mode 3) (Un\G22528 to Un\G22777) or in "Documentation of I/O-Mapping" of the intelligent function utility.

FDL Addr.	Name	Model
3	Slave_Nr_002	ST1H-PB
10	Slave_Nr_001	QJ71PB93D
32	Slave_Nr_003	AJ95TB32-16DT 8 DI / 8DO

Order of assignment →

When parameters have been modified (deletion or addition of DP-Slave(s)) using the intelligent function utility, the buffer memory is reassigned.

After modifying parameters, review the sequence program.

If some DP-Slaves are expected to be connected to the network in the future, setting them as Reserved stations in the parameter setting eliminates the need to check the sequence program. (Refer to section 6.5)

Slave status area (Normal communication detection) (Un\G23040 to Un\G23047)

The communication status of each DP-Slave is stored in this area. (Initial value: 0000H)

When the Data exchange start request signal (Yn0) is turned OFF, all the information of the Slave status area (Normal communication detection) (Un\G23040 to Un\G23047) is cleared.

- 0: I/O data communication error, or no communication (including reserved, temporary slave reservation and/or not-configured stations)
- 1: Exchanging I/O data

Address DEC (HEX)	b15 b14 b13 b12 b11 b10 b9 b8 b7 b6 b5 b4 b3 b2 b1 b0															
	23040 (5A00H)	16	15	14	13	12	11	10	9	8	7	6	5	4	3	2
23041 (5A01H)	32	31	30	29	28	27	26	25	24	23	22	21	20	19	18	17
23042 (5A02H)	48	47	46	45	44	43	42	41	40	39	38	37	36	35	34	33
23043 (5A03H)	64	63	62	61	60	59	58	57	56	55	54	53	52	51	50	49
23044 (5A04H)	80	79	78	77	76	75	74	73	72	71	70	69	68	67	66	65
23045 (5A05H)	96	95	94	93	92	91	90	89	88	87	86	85	84	83	82	81
23046 (5A06H)	112	111	110	109	108	107	106	105	104	103	102	101	100	99	98	97
23047 (5A07H)	①	①	①	125	124	123	122	121	120	119	118	117	116	115	114	113

← Each bit indicates the n-th DP-Slave

Fig. 3-17: Slave status area (normal communication detection) (Un\G23040 to Un\G23047)

① Bits b13 to b15 of address 23047 (5A07H) are fixed to 0.

Turning ON the Data exchange start request signal (Yn0) updates the information in the Slave status area (Normal communication detection) (Un\G23040 to Un\G23047), turning ON (1) the bits of the DP-Slave currently exchanging I/O data.

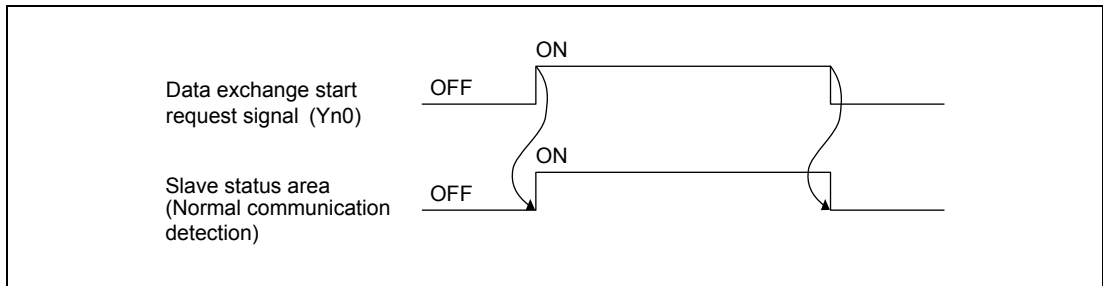

Fig. 3-18: Operation in slave status area (normal communication detection) (when I/O data exchange is normal)

When an I/O data communication error occurs on a DP-Slave, the corresponding bit turns OFF (0), and it turns ON (1) again when normal status is restored.

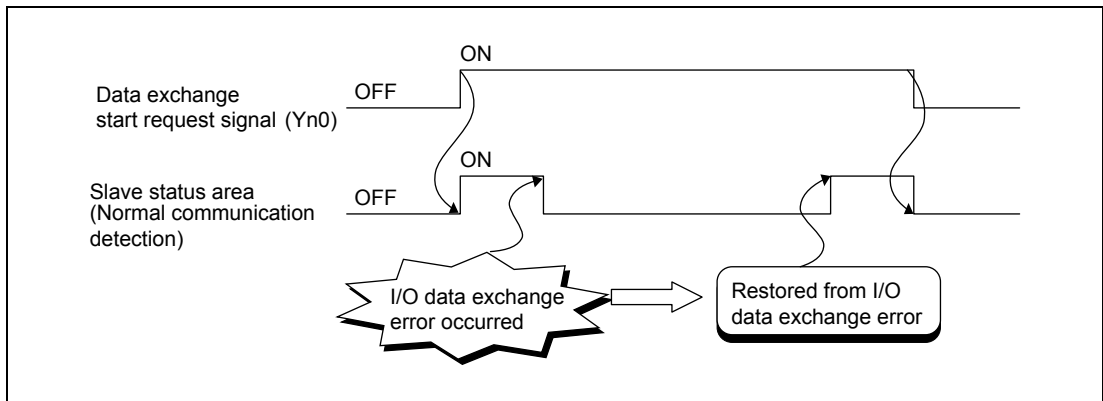

Fig. 3-19: Operation in slave status area (normal communication detection) (when I/O data exchange error occurred)

Slave status area (Reserved station setting status) (Un\G23048 to Un\G23055)

This area stores the reserved or temporary slave reservation setting of each DP-Slave. (Initial value: 0000H)

- 0: Normal DP-Slave or not-configured station
- 1: Reserved or temporary slave reservation

Address DEC (HEX)	b15	b14	b13	b12	b11	b10	b9	b8	b7	b6	b5	b4	b3	b2	b1	b0
23048 (5A08H)	16	15	14	13	12	11	10	9	8	7	6	5	4	3	2	1
23049 (5A09H)	32	31	30	29	28	27	26	25	24	23	22	21	20	19	18	17
23050 (5A0AH)	48	47	46	45	44	43	42	41	40	39	38	37	36	35	34	33
23051 (5A0BH)	64	63	62	61	60	59	58	57	56	55	54	53	52	51	50	49
23052 (5A0CH)	80	79	78	77	76	75	74	73	72	71	70	69	68	67	66	65
23053 (5A0DH)	96	95	94	93	92	91	90	89	88	87	86	85	84	83	82	81
23054 (5A0EH)	112	111	110	109	108	107	106	105	104	103	102	101	100	99	98	97
23055 (5A0FH)	①	①	①	125	124	123	122	121	120	119	118	117	116	115	114	113

← Each bit indicates the n-th DP-Slave

Fig. 3-20: Slave status area (reserved station setting status) (Un\G23048 to Un\G23055)

① Bits b13 to b15 of address 23055 (5A0FH) are fixed to 0.

When the Data exchange start completed signal (Xn0) is turned ON, the data in the Slave status area (Reserved station setting status) (Un\G23048 to Un\G23055) are updated.

The following is an example.

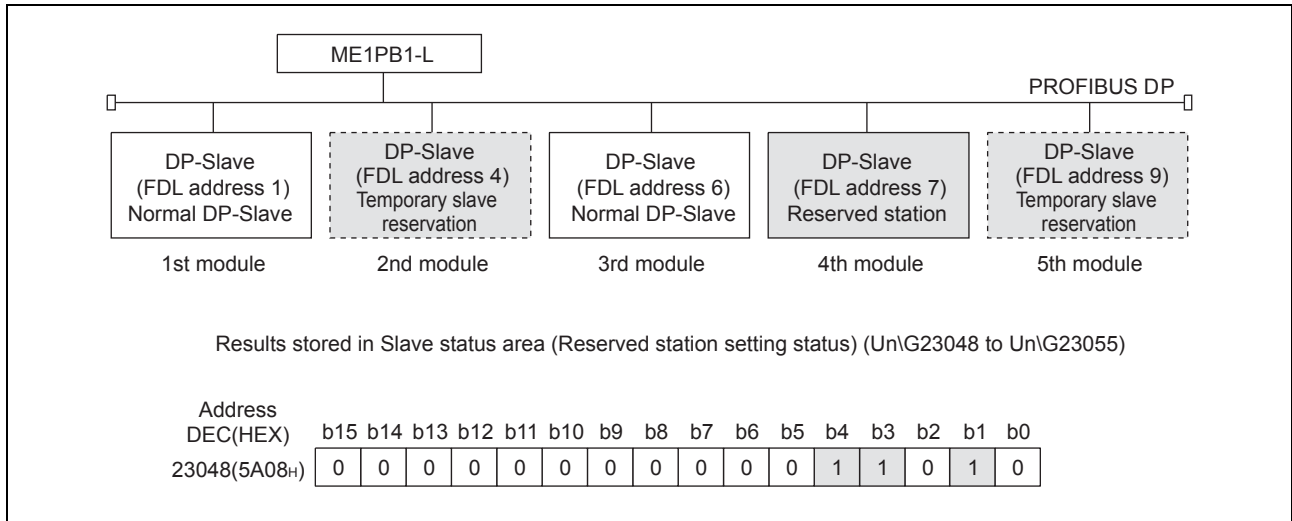

Fig. 3-21: Example for the entry in the slave status area (Reserved Station Setting Status)

Slave status area (Diagnostic information detection) (Un\G23056 to Un\G23064)

The information on diagnostic status of each DP-Slave is stored in this area.

When the Data exchange start request signal (Yn0) is turned OFF, all the information of the Slave status area (Diagnostic information detection) (Un\G23056 to Un\G23064) is cleared.

- All stations' diagnostic status (Un\G23056)

This area stores the diagnostic information detection status of all DP-Slaves. (Initial value: 0000H)

If diagnostic information is detected in any one of the stations in Each station's diagnostic status (Un\G23057 to Un\G23064), 1 is stored in All stations' diagnostic status (Un\G23056).

- 0: All DP-Slaves normal
- 1: Diagnostic error information detected

- Each station's diagnostic status (Un\G23057 to Un\G23064)

This area stores the diagnostic information detection status of each DP-Slave. (Initial value: 0000H)

- 0: Normal (including reserved, temporary slave reservation and/or not-configured stations)
- 1: Diagnostic information detected

Address DEC (HEX)	b15	b14	b13	b12	b11	b10	b9	b8	b7	b6	b5	b4	b3	b2	b1	b0
23057 (5A11H)	16	15	14	13	12	11	10	9	8	7	6	5	4	3	2	1
23058 (5A12H)	32	31	30	29	28	27	26	25	24	23	22	21	20	19	18	17
23059 (5A13H)	48	47	46	45	44	43	42	41	40	39	38	37	36	35	34	33
23060 (5A14H)	64	63	62	61	60	59	58	57	56	55	54	53	52	51	50	49
23061 (5A15H)	80	79	78	77	76	75	74	73	72	71	70	69	68	67	66	65
23062 (5A16H)	96	95	94	93	92	91	90	89	88	87	86	85	84	83	82	81
23063 (5A17H)	112	111	110	109	108	107	106	105	104	103	102	101	100	99	98	97
23064 (5A18H)	①	①	①	125	124	123	122	121	120	119	118	117	116	115	114	113

← Each bit indicates the n-th DP-Slave

Fig. 3-22: Each station's diagnostic status (Un\G23057 to Un\G23064)

① Bits b13 to b15 of address 23064 (5A18H) are fixed to 0.

Parameter setting status area (Active station) (Un\G23584 to Un\G23591)

This area stores data of the DP-Slaves that are set to Normal DP-Slave by the slave parameters. (Initial value: 0000H)

The set data are stored when the Communication READY signal (X(n+1)B) turns ON.

- 0: Reserved or not-configured station
- 1: Normal DP-Slave

Address DEC (HEX)	b15	b14	b13	b12	b11	b10	b9	b8	b7	b6	b5	b4	b3	b2	b1	b0
23584 (5C20H)	16	15	14	13	12	11	10	9	8	7	6	5	4	3	2	1
23585 (5C21H)	32	31	30	29	28	27	26	25	24	23	22	21	20	19	18	17
23586 (5C22H)	48	47	46	45	44	43	42	41	40	39	38	37	36	35	34	33
23587 (5C23H)	64	63	62	61	60	59	58	57	56	55	54	53	52	51	50	49
23588 (5C24H)	80	79	78	77	76	75	74	73	72	71	70	69	68	67	66	65
23589 (5C25H)	96	95	94	93	92	91	90	89	88	87	86	85	84	83	82	81
23590 (5C26H)	112	111	110	109	108	107	106	105	104	103	102	101	100	99	98	97
23591 (5C27H)	①	①	①	125	124	123	122	121	120	119	118	117	116	115	114	113

← Each bit represents the n-th DP-Slave

Fig. 3-23: Parameter setting status area (active station) (Un\G23584 to Un\G23591)

① Bits b13 to b15 of address 23591 (5C27H) are fixed to 0.

Parameter setting status area (Reserved station) (Un\G23592 to Un\G23599)

This area stores data of the DP-Slaves that are set to Reserved station by the slave parameters. (Initial value: 0000H)

The set data are stored when the Communication READY signal (X(n+1)B) turns ON.

- 0: Normal DP-Slave or not-configured station
- 1: Reserved station

Address DEC (HEX)	b15	b14	b13	b12	b11	b10	b9	b8	b7	b6	b5	b4	b3	b2	b1	b0
23592 (5C28H)	16	15	14	13	12	11	10	9	8	7	6	5	4	3	2	1
23593 (5C29H)	32	31	30	29	28	27	26	25	24	23	22	21	20	19	18	17
23594 (5C2AH)	48	47	46	45	44	43	42	41	40	39	38	37	36	35	34	33
23595 (5C2BH)	64	63	62	61	60	59	58	57	56	55	54	53	52	51	50	49
23596 (5C2CH)	80	79	78	77	76	75	74	73	72	71	70	69	68	67	66	65
23597 (5C2DH)	96	95	94	93	92	91	90	89	88	87	86	85	84	83	82	81
23598 (5C2EH)	112	111	110	109	108	107	106	105	104	103	102	101	100	99	98	97
23599 (5C2FH)	①	①	①	125	124	123	122	121	120	119	118	117	116	115	114	113

← Each bit represents the n-th DP-Slave

Fig. 3-24: Parameter setting status area (reserved station) (Un\G23592 to Un\G23599)

① Bits b13 to b15 of address 23599 (5C2FH) are fixed to 0.

Temporary slave reservation status area (Un\G23600 to Un\G23607)

This area stores data of the DP-Slaves that are set to temporary slave reservation by the temporary slave reservation function. (Initial value: 0000H)

The setting is stored when the Data exchange start completed signal (Xn0) turns ON. (Refer to section 3.6.13)

- 0: Normal DP-Slave, reserved or not-configured station
- 1: Temporary slave reservation

Address DEC (HEX)	b15	b14	b13	b12	b11	b10	b9	b8	b7	b6	b5	b4	b3	b2	b1	b0
23600 (5C30H)	16	15	14	13	12	11	10	9	8	7	6	5	4	3	2	1
23601 (5C31H)	32	31	30	29	28	27	26	25	24	23	22	21	20	19	18	17
23602 (5C32H)	48	47	46	45	44	43	42	41	40	39	38	37	36	35	34	33
23603 (5C33H)	64	63	62	61	60	59	58	57	56	55	54	53	52	51	50	49
23604 (5C34H)	80	79	78	77	76	75	74	73	72	71	70	69	68	67	66	65
23605 (5C35H)	96	95	94	93	92	91	90	89	88	87	86	85	84	83	82	81
23606 (5C36H)	112	111	110	109	108	107	106	105	104	103	102	101	100	99	98	97
23607 (5C37H)	①	①	①	125	124	123	122	121	120	119	118	117	116	115	114	113

← Each bit represents the n-th DP-Slave

Fig. 3-25: Temporary slave reservation status area (Un\G23600 to Un\G23607)

① Bits b13 to b15 of address 23607 (5C37H) are fixed to 0.

Slave status area (Alarm detection) (Un\G26416 to Un\G26424)

The information on alarm status of each DP-Slave is stored in this area.

- All stations' alarm status (Un\G26416)

This area stores the alarm detection status of all DP-Slaves. (Initial value: 0000H)

If an alarm is detected in any one of the stations in Each station's alarm status (Un\G26417 to Un\G26424), 1 is stored in All stations' alarm status (Un\G26416).

- 0: No alarm in all DP-Slaves
- 1: Alarm detected

- Each station's alarm status (Un\G26417 to Un\G26424)

This area stores the alarm detection status of each DP-Slave. (Initial value: 0000H)

If an alarm is detected in any one of the stations and the corresponding bit turns ON (1) in Each station's alarm status (Un\G26417 to Un\G26424), the RSP ERR.LED turns ON.

- 0: No alarm (including reserved, temporary slave reservation, not-configured and/or non-alarm-ready stations)
- 1: Alarm generated

Address DEC (HEX)	b15	b14	b13	b12	b11	b10	b9	b8	b7	b6	b5	b4	b3	b2	b1	b0
26417 (6731H)	16	15	14	13	12	11	10	9	8	7	6	5	4	3	2	1
26418 (6732H)	32	31	30	29	28	27	26	25	24	23	22	21	20	19	18	17
26419 (6733H)	48	47	46	45	44	43	42	41	40	39	38	37	36	35	34	33
26420 (6734H)	64	63	62	61	60	59	58	57	56	55	54	53	52	51	50	49
26421 (6735H)	80	79	78	77	76	75	74	73	72	71	70	69	68	67	66	65
26422 (6736H)	96	95	94	93	92	91	90	89	88	87	86	85	84	83	82	81
26423 (6737H)	112	111	110	109	108	107	106	105	104	103	102	101	100	99	98	97
26424 (6738H)	①	①	①	125	124	123	122	121	120	119	118	117	116	115	114	113

← Each bit indicates the n-th DP-Slave

Fig. 3-26: Each station's alarm status (Un\G26417 to Un\G26424)

① Bits b13 to b15 of address 23424 (6738H) are fixed to 0.

3.6.6 Diagnostic information area

This area stores diagnostic information settings and actual diagnostic information.

Diagnostic information non-notification time setting area (Un\G2084)

The time during which no diagnostic information is notified after communication start (after Data exchange start completed signal (Xn0) turns ON) is set in this area. (Initial value: 20 seconds)

Set value	Description
0 to 65535	Set the time during which diagnostic information is not notified. (Unit: seconds)

Tab. 3-15: Diagnostic information non-notification time setting area (Un\G2084)

This setting prevents temporary error detection. (e.g. when turning ON a DP-Slave after turning ON the ME1PB1-L)

When diagnostic information is generated within the time duration set by this setting, the conditions are as follows:

- The Diagnostic information detection signal (Xn1) does not turn ON.
- The R ERR. LED does not turn ON.
- No error code and detailed data is stored in the Diagnostic information area (for mode 3) (Un\G2307 to Un\G23321) and/or Extended diagnostic information area (for mode 3) (Un\G23328 to Un\G23454).
- The bit corresponding to the station that sent the diagnostic information does not turn ON in the Slave status area (Diagnostic information detection) (Un\G23056 to Un\G23064).

NOTES

Set a value into the Diagnostic information non-notification time setting area (Un\G2084) when the Data exchange start request signal (Yn0) is OFF.

Values set with the Data exchange start request signal (Yn0) ON are ignored.

The time (remaining time) during which no diagnostic information is notified after communication start (after Data exchange start completed signal (Xn0) turns ON) can be checked in the Current diagnostic information non-notification time area (Un\G2085).

Current diagnostic information non-notification time area (Un\G2085)

This area stores the remaining time during which no diagnostic information is notified after communication start (after Data exchange start completed signal (Xn0) turns ON). (initial value: 0 seconds)

The non-notification time is set in the Diagnostic information non-notification time setting area (Un\G2084).

Stored value	Description
0 to 65535	A countdown time (remaining time), during which no diagnostic information is notified, is stored. (Unit: seconds) No diagnostic information is notified until the value reaches 0.

Tab. 3-16: Current diagnostic information non-notification time area (Un\G2085)

When the time set in the Diagnostic information non-notification time setting area (Un\G2084) has elapsed after communication start (after Data exchange start completed signal (Xn0) turns ON), the value in the Current diagnostic information non-notification time area (Un\G2085) becomes 0.

While communication is stopped (Data exchange start request signal (Yn0): OFF), the remaining time is held until the Data exchange start request signal (Yn0) is turned ON again.

Diagnostic information invalid setting area (Un\G2080)

Setting some values to this area can mask (invalidate) any data of the diagnostic information that is sent from a DP-Slave during communication. (Initial value: 02B9_H)

- 0: Validates the diagnostic information.
- 1: Invalidates the diagnostic information.

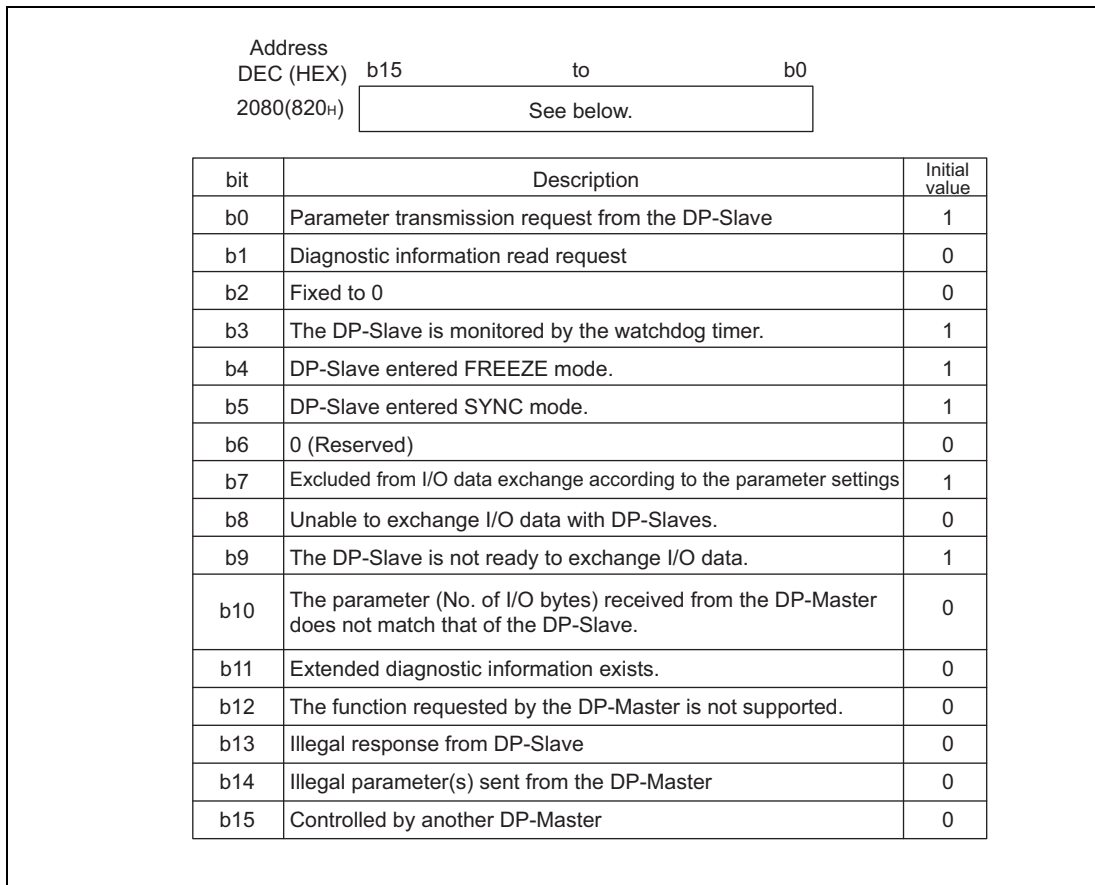

Fig. 3-27: Diagnostic information invalid setting area (Un\G2080)

Even if diagnostic information corresponding to each bit is generated on a DP-Slave, it is not recognized as diagnostic information, and the status of the ME1PB1-L is as follows:

- The Diagnostic information detection signal (Xn1) does not turn ON.
- The R ERR. LED does not turn ON.
- No error code and detailed data is stored in the Diagnostic information area (for mode 3) (Un\G2307 to Un\G23321) and/or Extended diagnostic information area (for mode 3) (Un\G23328 to Un\G23454).
- The bit corresponding to the station that sent the diagnostic information does not turn ON in the Slave status area (Diagnostic information detection) (Un\G23056 to Un\G23064).

NOTE

Set values into the Diagnostic information invalid setting area (Un\G2080) when the Data exchange start request signal (Yn0) is OFF.
 Values set with the Data exchange start request signal (Yn0) ON are ignored.

Diagnostic information area (for mode 3) (Un\G23072 to Un\G23321)

- ① This area stores the diagnostic information generated on DP-Slaves during communication. Information of 125 modules is stored in Diagnostic information area (for mode 3) in the same order for each module.

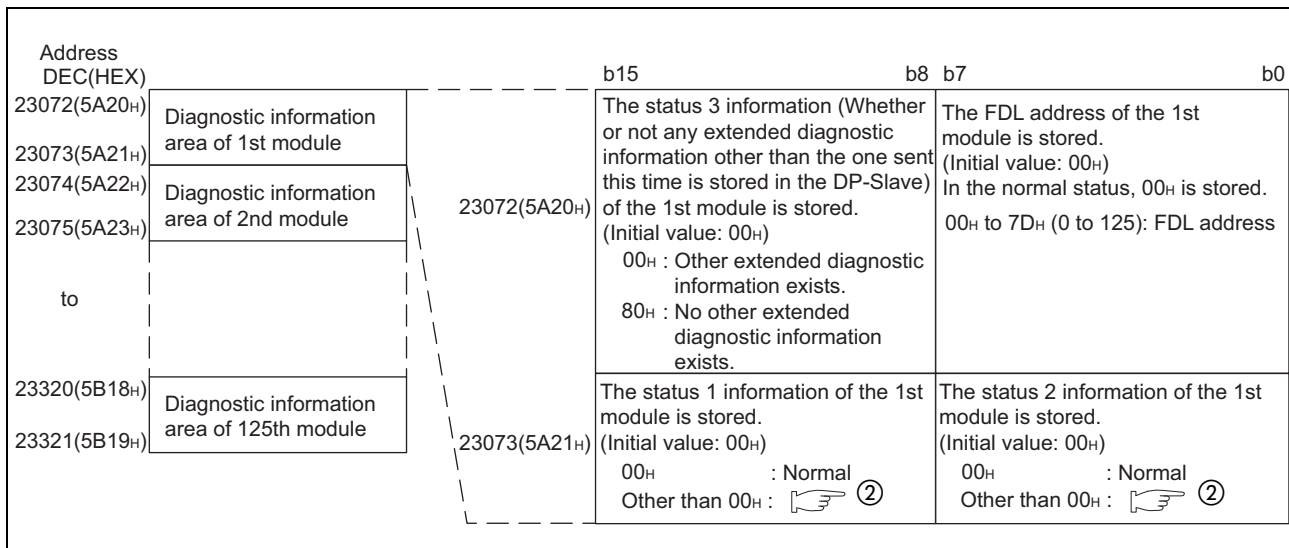

Fig. 3-28: Diagnostic information area (for mode 3) (Un\G23072 to Un\G23321)

NOTES

Data are assigned to the Diagnostic information area (for mode 3) in the order of the parameters set with the intelligent function utility (in the order of FDL addresses).

The actual order of assignment can be checked in Address information area (for mode 3) (Un\G22528 to Un\G22777) or in "Documentation of I/O-Mapping" of the intelligent function utility.

FDL Addr.	Name	Model
3	Slave_Nr_002	ST1H-PB
10	Slave_Nr_001	QJ71PB93D
32	Slave_Nr_003	AJ95TB32-16DT 8 DI / 8DO

Order of assignment →

When parameters have been modified (deletion or addition of DP-Slave(s)) by the intelligent function utility, the buffer memory is reassigned.

After modifying parameters, review the sequence program.

If some DP-Slaves are expected to be connected to the network in the future, setting them as Reserved stations in the parameter setting eliminates the need to check the sequence program. (Refer to section 6.5)

The information in Diagnostic information area (for mode 3) (Un\G23072 to Un\G23321) is not cleared even if the problem occurred on the DP-Slave has been solved.

To clear the information in Diagnostic information area (for mode 3) (Un\G23072 to Un\G23321), turn ON the Diagnostic information area clear request signal (Yn2).

② Information of status 1 and 2

The diagnostic information generated on DP-Slaves is stored to status 1 and 2, and corresponding bits turn ON (1).

I/O data exchange between a DP-Master and DP-Slaves is continued even if any of the following errors occurs.

The following table lists the meaning of each bit, actions to be taken, and the station where the diagnostic information is detected.

Item	Bit	Description	Action	Detected in
Status 2	b0	Requesting transmission of parameters from DP-Slave	<ul style="list-style-type: none"> When I/O data exchange is started Normally operating (This occurs every time I/O data exchange is started.) While I/O data are exchanged Check the DP-Slave status and communication line. 	DP-Slave
	b1	Diagnostic information read request	Check the DP-Slave status.	DP-Slave
	b2	0 (Fixed)	—	—
	b3	The DP-Slave is monitored by the watchdog timer.	Normally operating	DP-Slave
	b4	The DP-Slave entered FREEZE mode.		
	b5	The DP-Slave entered SYNC mode.		
	b6	0 (Reserved)	—	—
b7	Excluded from I/O data exchange according to the parameter settings	<ul style="list-style-type: none"> When I/O data exchange is stopped Normally operating (This occurs every time I/O data exchange is stopped.) While I/O data are exchanged Check if any parameter has been changed from the DP-Master (Class 2) on the network. 	DP-Master	
Status 1	b8	Unable to exchange I/O data with DP-Slaves.	Check the DP-Slave status and communication line. Check the parameters.	DP-Master
	b9	The DP-Slave is not ready to exchange I/O data.	<ul style="list-style-type: none"> When I/O data exchange is started Normally operating (This occurs every time I/O data exchange is started.) While I/O data are exchanged Check the DP-Slave status and communication line. 	DP-Slave
	b10	The parameter (No. of I/O bytes) received from the DP-Master does not match that of the DP-Slave.	Check the slave parameters.	DP-Slave
	b11	There is some extended diagnostic information.	Check the DP-Slave status.	DP-Master
	b12	The function requested by the DP-Master is not supported.	Check if the DP-Slave supports the global control function or not. Verify the DP-Slave specifications.	DP-Slave
	b13	Illegal response from DP-Slave	Check the DP-Slave or network status.	DP-Master
	b14	Illegal parameter(s) sent from the DP-Master	Check the parameters.	DP-Slave
b15	Controlled by another DP-Master.	Check if more than one DP-Master are communicating with the same DP-Slave. Check the parameters.	DP-Master	

Tab. 3-17: Diagnostic information

Extended diagnostic information area (for mode 3) (Un\G23328 to Un\G23454)

This area stores the latest extended diagnostic information occurred during communication.



Address DEC(HEX)	b15	b8 b7	b0
23328(5B20 _H)	The FDL address of the DP-Slave that notified of the latest extended diagnostic information in addresses 23329 to 23454 (5B21 _H to 5B9E _H), is stored. (Initial value: 0000 _H) 0000 _H to 007D _H (0 to 125) : FDL address		
23329(5B21 _H)	The data size of the latest extended diagnostic information in addresses 23330 to 23454 (5B22 _H to 5B9E _H) is stored. (Initial value : 0000 _H) 0006 _H to 00F4 _H : Data size of extended diagnostic information (unit: byte)		
23330(5B22 _H)	The latest information of status 1 is stored. (Initial value : 00 _H) 00 _H : Normal Other than 00 _H :  page 3-37 Point ②	The latest information of status 2 is stored. (Initial value : 00 _H) 00 _H : Normal Other than 00 _H :  page 3-37 Point ②	
23331(5B23 _H)	The latest status 3 information (Whether or not any extended diagnostic information other than the one sent this time is stored in the DP-Slave) is stored. (Initial value : 00 _H) 00 _H : No other extended diagnostic information exists. 80 _H : Other extended diagnostic information exists.	The latest FDL address of the DP-Master is stored. (Initial value : 00 _H) For the DP-Slave that has not started I/O data exchange, FF _H is stored. 00 _H to 7D _H (0 to 125) : FDL address	
23332(5B24 _H)	The latest ident No. of the DP-Slave is stored. (Initial value : 0000 _H)		
23333(5B25 _H)	The latest extended diagnostic information (max. 244 bytes) is stored. (Initial value : 0000 _H)		
to			
23454(5B9E _H)			

Fig. 3-29: Extended diagnostic information area (for mode 3) (Un\G23328 to Un\G23454)

NOTES

The information in Extended diagnostic information area (for mode 3) (Un\G23328 to Un\G23454) is not cleared even if corrective action is taken for the relevant error that has occurred on a DP-Slave.

To clear the information in Extended diagnostic information area (for mode 3) (Un\G23328 to Un\G23454), turn ON the Diagnostic information area clear request signal (Yn2).

When b11 of the Diagnostic information invalid setting area (Un\G2080) is set to ON (1), information is not stored in the Extended diagnostic information area (for mode 3) (Un\G23328 to Un\G23454).

3.6.7 Extended diagnostic information read area

This area is used to read the extended diagnostic information from DP-Slaves.

Extended diagnostic information read request area (Un\G23456)

Set the FDL address of the DP-Slave whose extended diagnostic information is to be read. (Initial value: FFFF_H)

Set value	Description
0000 _H to 007D _H (0 to 125)	Set the FDL address of the DP-Slave.

Tab. 3-18: Extended diagnostic information read request area (Un\G23456)

By setting the FDL address is set in the Extended diagnostic information read request area (Un\G23456) and turning ON the Extended diagnostic information read request signal (Yn6), the extended diagnostic information is stored in the Extended diagnostic information read response area (Un\G23457 to Un\G23583).

Extended diagnostic information read response area (Un\G23457 to Un\G23583)

The execution result of the extended diagnostic information read request is stored in this area.

If the request failed, the values in address 23458 to 23583 (5BA2_H to 5C1F_H) become 0_H.



Address DEC (HEX)	b15	b8	b7	b0
23457(5BA1 _H)	The read result is stored. (Initial value : 0000 _H) A200 _H : Normally completed Other than A200 _H : Failed (Error code  section 9.4.1)			
23458(5BA2 _H)	The data size of the extended diagnostic information in addresses 23459 to 23583 (5BA3 _H to 5C1F _H) is stored. (Initial value : 0000 _H) 0006 _H to 00F4 _H : Data size of extended diagnostic information (unit : byte)			
23459(5BA3 _H)	The information of status 1 is stored. (Initial value: 00 _H) 00 _H : Normal Other than 00 _H :  page 3-37 point ②		The latest information of status 2 is stored. (Initial value : 00 _H) 00 _H : Normal Other than 00 _H :  page 3-37 point ②	
23460(5BA4 _H)	The status 3 information (Whether or not any extended diagnostic information other than the one sent this time is stored in the DP-Slave) is stored. (Initial value : 00 _H) 00 _H : No other extended diagnostic information exists. 80 _H : Other extended diagnostic information exists.		The FDL address of the DP-Master is stored. (Initial value: 00 _H) For the DP-Slave that has not started I/O data exchange, FF _H is stored. 00 _H to 7D _H (0 to 125) : FDL address	
23461(5BA5 _H)	The ident No. of the DP-Slave is stored. (Initial value : 0000 _H)			
23462(5BA6 _H) to 23583(5C1F _H)	The extended diagnostic information (max. 244 bytes) is stored. (Initial value : 0000 _H)			

Fig. 3-30: Extended diagnostic information read response area (Un\G23457 to Un\G23583)

3.6.8 Bus cycle time area

This area stores the bus cycle time.

Current bus cycle time (Un\G2272)

The current bus cycle time is stored in this area. (Unit: × 1ms)

Min. bus cycle time (Un\G2273)

The minimum value of the bus cycle time is stored in this area. (Unit: × 1ms)

Max. bus cycle time (Un\G2274)

The maximum value of the bus cycle time is stored in this area. (Unit: × 1ms)

3.6.9 Global control area

This area is used for the global control function.

Global control area (Un\G2081)

● **Set the global control function to be executed.**

Specify the global control service to be sent by bits b5 to b2 in the Global control area, and set the target group No. by bits b15 to b8. (Initial value: 0000H)

0: Not execute

1: Execute



bit	Description	Initial value	Reference Section
b0	Unused (Fixed to 0)	0	—
b1	Unused (Fixed to 0)	0	 page 3-41 (Setting global control services)
b2	UNFREEZE (Retention of the actual input data is disabled.)	0	
b3	FREEZE (Actual input data is held and read.)	0	
b4	UNSYNC (Retention of the actual input data is disabled.)	0	
b5	SYNC (Actual output data is written and held.)	0	—
b6	Unused (Fixed to 0)	0	 page 3-41 (Setting the target group No.)
b7	Unused (Fixed to 0)	0	
b8	Executed on DP-Slaves in group 1	0	
b9	Executed on DP-Slaves in group 2	0	
b10	Executed on DP-Slaves in group 3	0	
b11	Executed on DP-Slaves in group 4	0	
b12	Executed on DP-Slaves in group 5	0	
b13	Executed on DP-Slaves in group 6	0	
b14	Executed on DP-Slaves in group 7	0	
b15	Executed on DP-Slaves in group 8	0	

Fig. 3-31: Global control area (Un\G2081)

● **Setting global control services (b5 to b2)**

The following service combinations are not executable at the same time.

- SYNC and UNSYNC (If both services are attempted concurrently, UNSYNC only is enabled.)
- FREEZE and UNFREEZE (If both services are attempted concurrently, UNFREEZE only is enabled.)

The following shows the services and their set values for b5 to b2.

● **Setting for execution of the SYNC and UNSYNC services**

Service to be executed	Set value	
	b5	b4
SYNC	1	0
UNSYNC	0 ^①	1

Tab. 3-19: SYNC/UNSYNC settings (b5, b4)

① When 1 is set to this bit, it is handled as an invalid value. (The operation is the same as when the value is set to 0.)

● **Setting for execution of the FREEZE and UNFREEZE services**

Service to be executed	Set value	
	b3	b2
FREEZE	1	0
UNFREEZE	0 ^①	1

Tab. 3-20: FREEZE/UNFREEZE settings (b3, b2)

① When 1 is set to this bit, it is handled as an invalid value. (The operation is the same as when the value is set to 0.)

● **Setting the target group No. (b15 to b8)**

Multiple group Nos. can be set for the target group No.

When 0s are set to all of b8 to b15, the set global control service is sent to all DP-Slaves (including DP-Slaves for which group No. is not set).

NOTE

For details on the global control, refer to section 4.1.3.

3.6.10 Acyclic communication area

This area is used for acyclic communications.

Acyclic communication request area (Un\G23809 to Un\G24832)

Set the request instruction of acyclic communication in this area. (Initial value: 0000H)

Up to eight request instructions can be set.

For the format for request instructions, refer to section 7.3.

Address DEC (HEX)	
23809 (5D01H) to 23936 (5D80H)	Request instruction No. 1 area (Data size: 128 words)
23937 (5D81H) to 24064 (5E00H)	Request instruction No. 2 area (Data size 128 words)
24065 (5E01H) to 24192 (5E80H)	Request instruction No. 3 area (Data size 128 words)
24193 (5E81H) to 24320 (5F00H)	Request instruction No. 4 area (Data size 128 words)
24321 (5F01H) to 24448 (5F80H)	Request instruction No. 5 area (Data size 128 words)
24449 (5F81H) to 24576 (6000H)	Request instruction No. 6 area (Data size 128 words)
24577 (6001H) to 24704 (6080H)	Request instruction No. 7 area (Data size 128 words)
24705 (6081H) to 24832 (6100H)	Request instruction No. 8 area (Data size 128 words)

Fig. 3-32: Acyclic communication request area (Un\G23809 to Un\G24832)

Acyclic communication request execution instruction area (Un\G23808)

Set the execution instruction for acyclic communication in this area.

When a bit is turned ON (1), the request instruction corresponding to the bit is executed. (Initial value: 0000H)

0: Not execute

1: Execute

Address DEC (HEX)	Bit	Description	Initial value
23808 (5D00H)	b0	Execution instruction of request instruction No. 1	0
	b1	Execution instruction of request instruction No. 2	0
	b2	Execution instruction of request instruction No. 3	0
	b3	Execution instruction of request instruction No. 4	0
	b4	Execution instruction of request instruction No. 5	0
	b5	Execution instruction of request instruction No. 6	0
	b6	Execution instruction of request instruction No. 7	0
	b7	Execution instruction of request instruction No. 8	0
	b8	00H (Fixed)	0
	b9		0
	b10		0
	b11		0
	b12		0
	b13		0
	b14		0
	b15		0

Tab. 3-21: Acyclic communication request execution instruction area (Un\G23808)

Acyclic communication request result area (Un\G25120)

This area stores the request acceptance status and request execution completion status of acyclic communication.

Bits b0 to b7

- 0: Not accepted
- 1: Accepted

Bits b8 to b15

- 0: Not executed or in execution
- 1: Execution completed

Address DEC (HEX)	Bit	Description	Initial value
25120 (6220H)	b0	Acceptance status of request instruction No. 1	0
	b1	Acceptance status of request instruction No. 2	0
	b2	Acceptance status of request instruction No. 3	0
	b3	Acceptance status of request instruction No. 4	0
	b4	Acceptance status of request instruction No. 5	0
	b5	Acceptance status of request instruction No. 6	0
	b6	Acceptance status of request instruction No. 7	0
	b7	Acceptance status of request instruction No. 8	0
	b8	Completion status of request instruction No. 1	0
	b9	Completion status of request instruction No. 2	0
	b10	Completion status of request instruction No. 3	0
	b11	Completion status of request instruction No. 4	0
	b12	Completion status of request instruction No. 5	0
	b13	Completion status of request instruction No. 6	0
	b14	Completion status of request instruction No. 7	0
	b15	Completion status of request instruction No. 8	0

Tab. 3-22: *Acyclic communication request result area (Un\G25120)*

Acyclic communication response area (Un\G25121 to Un\G26144)

The execution result of acyclic communication is stored in this area. (Initial value: 0000H)

For the response format for the execution result, refer to section 7.3.

Address DEC (HEX)	
25121 (6221H) to 25248 (62A0H)	Response area for request instruction No. 1 (Data size: 128 words)
25249 (62A1H) to 25376 (6320H)	Response area for request instruction No. 2 (Data size: 128 words)
25377 (6321H) to 25504 (63A0H)	Response area for request instruction No. 3 (Data size: 128 words)
25505 (63A1H) to 25632 (6420H)	Response area for request instruction No. 4 (Data size: 128 words)
25633 (6421H) to 25760 (64A0H)	Response area for request instruction No. 5 (Data size: 128 words)
25761 (64A1H) to 25888 (6520H)	Response area for request instruction No. 6 (Data size: 128 words)
25889 (6521H) to 26016 (65A0H)	Response area for request instruction No. 7 (Data size: 128 words)
26017 (65A1H) to 26144 (6620H)	Response area for request instruction No. 8 (Data size: 128 words)

Fig. 3-33: Acyclic communication response area (Un\G25121 to Un\G26144)

3.6.11 Alarm area

This area is used for the alarm acquisition.

Alarm request area (Un\G26432 to Un\G26434)

Set request data for alarm acquisition in this area. (Initial value: 0000H)

For the request format, refer to section 7.4.

Alarm response area (Un\G26446 to Un\G26768)

The execution result of alarm acquisition is stored in this area. (Initial value: 0000H)

For the response format for the execution result, refer to section 7.4.

3.6.12 Time control area

This area is used for the time control.

Time control setting request area (Un\G26784 to Un\G26792)

Set request data for the time control setting in this area. (Initial value: 0000H)

For the request format, refer to section 7.5.

Time control setting response area (Un\G26800 to Un\G26812)

The execution result of the time control setting is stored in this area. (Initial value: 0000H)

For the response format for the execution result, refer to section 7.5.

3.6.13 Temporary slave reservation area

This area is used for the temporary slave reservation function.

NOTES

The corresponding bits of the Temporary slave reservation area are assigned in order of the parameters set with the intelligent function utility (in order of the FDL address).

The actual order of assignment can be checked in Address information area (for mode 3) (Un\G22528 to Un\G22777) or in "Documentation of I/O-Mapping" of the intelligent function utility.

FDL Addr.	Name	Model
3	Slave_Nr_002	ST1H-PB
10	Slave_Nr_001	QJ71PB93D
32	Slave_Nr_003	AJ95TB32-16DT 8 DI / 8DO

Order of assignment →

When parameters have been modified (deletion or addition of DP-Slave(s)) with the intelligent function utility, the order of the assigned DP-Slaves is changed.

After modifying parameters, check the sequence program.

If some DP-Slaves are expected to be connected to the network in the future, setting them as Reserved stations in the parameter setting eliminates the need to check the sequence program. (Refer to section 6.5)

Temporary slave reservation request area (Un\G23608 to Un\G23615)

This area is used to set DP-Slaves to Temporary slave reservation using the temporary slave reservation function. (Initial value: 0000H)

0: Not specify the DP-Slave to Temporary slave reservation

1: Specify the DP-Slave to Temporary slave reservation

Address DEC (HEX)	b15	b14	b13	b12	b11	b10	b9	b8	b7	b6	b5	b4	b3	b2	b1	b0
23608 (5C38H)	16	15	14	13	12	11	10	9	8	7	6	5	4	3	2	1
23609 (5C39H)	32	31	30	29	28	27	26	25	24	23	22	21	20	19	18	17
23610 (5C3AH)	48	47	46	45	44	43	42	41	40	39	38	37	36	35	34	33
23611 (5C3BH)	64	63	62	61	60	59	58	57	56	55	54	53	52	51	50	49
23612 (5C3CH)	80	79	78	77	76	75	74	73	72	71	70	69	68	67	66	65
23613 (5C3DH)	96	95	94	93	92	91	90	89	88	87	86	85	84	83	82	81
23614 (5C3EH)	112	111	110	109	108	107	106	105	104	103	102	101	100	99	98	97
23615 (5C3FH)	①	①	①	125	124	123	122	121	120	119	118	117	116	115	114	113

← Each bit indicates the n-th DP-Slave

Fig. 3-34: Temporary slave reservation request area (Un\G23608 to Un\G23615)

① Bits b13 to b15 of address 23615 (5C3FH) are fixed to 0.

When the Data exchange start request signal (Yn0) is turned ON, the DP-Slaves specified in the Temporary slave reservation request area (Un\G23608 to Un\G23615) become temporary slave reservation.

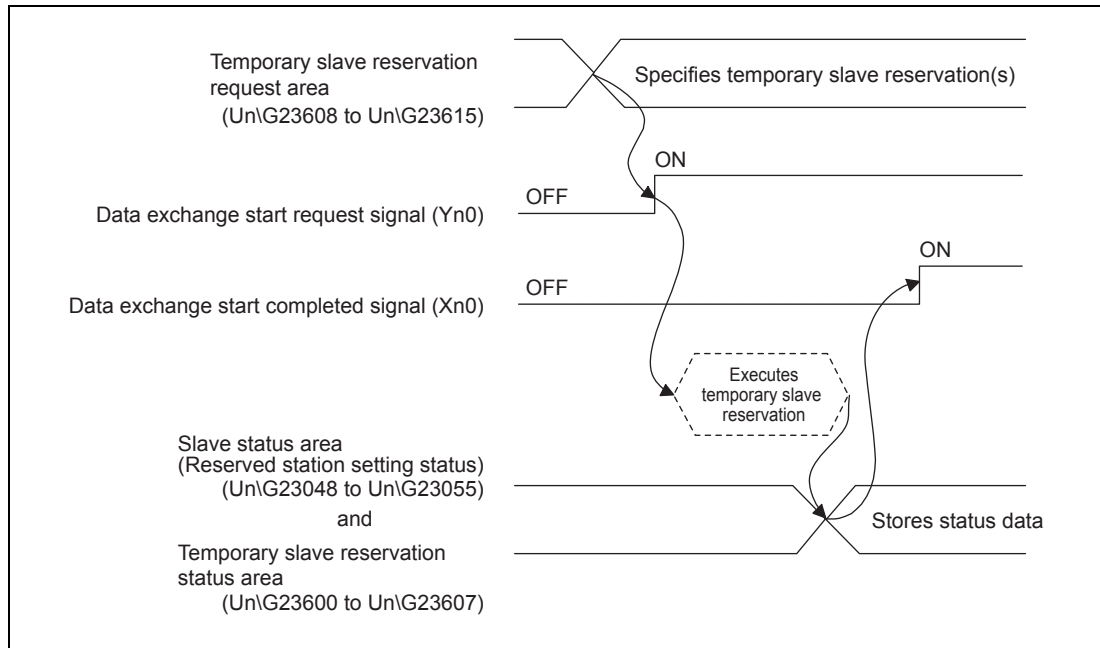

Fig. 3-35: Operation in temporary slave reservation request area

NOTES

Set values in the Temporary slave reservation request area (Un\G23608 to Un\G23615) while the Data exchange start request signal (Yn0) is OFF.

Values set with the Data exchange start request signal (Yn0) ON are ignored.

Normal DP-Slaves can be changed to Temporary slave reservations.

Changing Reserved stations (DP-Slaves set as reserved stations with slave parameters) to Normal DP-Slave status is not allowed.

For the temporary slave reservation function, refer to section 4.7.

3.7 Processing Times

This section explains the bus cycle time and transmission delay time.

3.7.1 Bus Cycle Time

When a single DP-Master is used

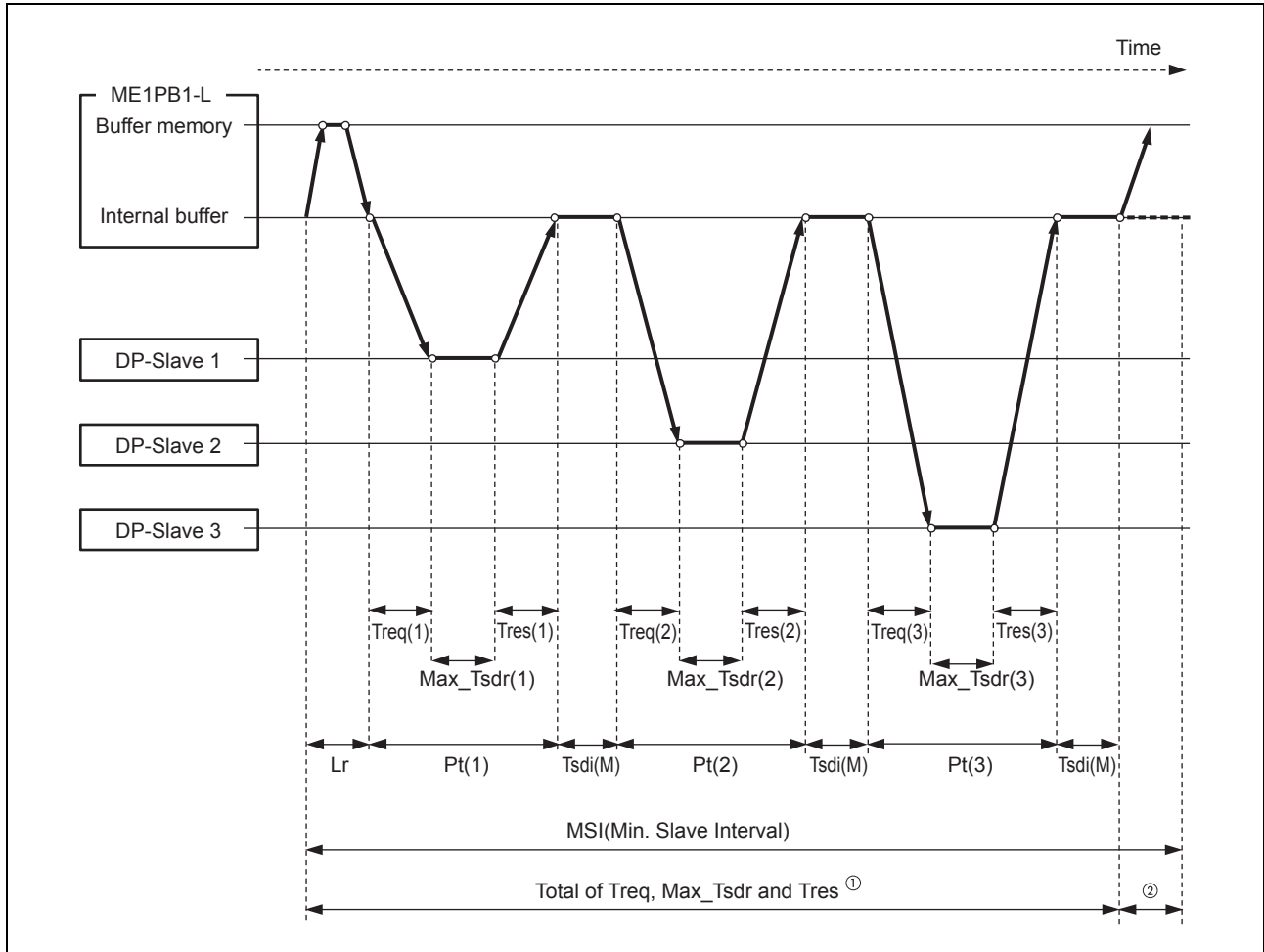

Fig. 3-36: Bus cycle time (DP-Master: 1, DP-Slave: 3)

- ① "MSI (Minimum polling cycle)" or "Total of Treq, Max_Tsdr and Tres", whichever is greater is Bc (Bus cycle time). (Refer to page 3-50)
- ② If "MSI (Minimum polling cycle)" is greater than "Total of Treq, Max_Tsdr and Tres", the ME1PB1-L transfers data from the internal buffer to the buffer memory within the "MSI (Minimum polling cycle)".

Bus cycle time (Bc) calculation formula

The bus cycle time (Bc) of the DP-Master can be obtained from the following calculation formula. The symbols within the brackets [] indicate units.

$$Bc[ms] = \text{Max} \left(\text{MSI}, \sum_{i=1}^n (Pt_{(i)} + Tsd_{i(M)}) + Lr \right)$$

n = number of DB-Slaves

Max (A, B) = A or B, whichever is greater

Item	Description
MSI [ms]	Minimum polling cycle (Min. slave interval) ①
Pt _(i) [ms]	(Polling time to i-th station) = Treq _(i) + Max_Tsdr _(i) + Tres _(i) • Treq _(i) [ms] = (Request transmission time of i-th station) = [{(Number of bytes output to i-th station) + 9} × 11[bit]] × 10 ³ / (Transmission speed [bps]) • Max_Tsdr _(i) [ms] = (Response time [T _{Bit}] of i-th station) ②③ × 10 ³ / (Transmission speed [bps]) • Tres _(i) [ms] = (Response transmission time of i-th station) = [{(Number of bytes input from i-th station) + 9} × 11 [bit]] × 10 ³ / (Transmission speed [bps])
Tsdi _(M) [ms]	(Request/response processing time [T _{Bit}] of DP-Master(ME1PB1-L) ④ × 10 ³ / (Transmission speed [bps])
Lr [ms]	(Data refresh time) = 5.50 + (Number of DP-Slaves) × 150 × 10 ⁻³

Tab. 3-23: Items in the bus cycle time (Bc) calculation formula

- ① The value set on the "Master Settings" screen of the intelligent function utility.
- ② The MaxTsdr value described in the GSD (DDB) file of the DP-Slave
- ③ [T_{Bit}] (Bit Time) is a unit that expresses the time required for 1-bit data transmission as "1".
 The actual processing time differs as shown below depending on the transmission speed:
Transmission speed is 1.5 Mbps:
 $1 [T_{Bit}] = 1 / (1.5 \times 10^6) = 0.667 \times 10^{-6} s = 0.667 \times 10^{-3} ms$
Transmission speed is 12 Mbps:
 $1 [T_{Bit}] = 1 / (12 \times 10^6) = 0.083 \times 10^{-6} s = 0.083 \times 10^{-3} ms$
- ④ The Tsdi value described in the GSD (DDB) file of the ME1PB1-L.
 The Tsdi value varies as shown below depending on the transmission speed.
 Refer to ③ for the unit [T_{Bit}].

Transmission speed	Request/Response processing time of DP-Master
9.6 kbps, 19.2 kbps, 93.75 kbps, 187.5 kbps	70T _{Bit}
500 kbps	150T _{Bit}
1.5 Mbps	200T _{Bit}
3 Mbps	250T _{Bit}
6 Mbps	450T _{Bit}
12 Mbps	800T _{Bit}

Tab. 3-24: Request/response processing time of DP-Master

Example ▽ Bus cycle time calculation example

The following shows a calculation example of the bus cycle time:

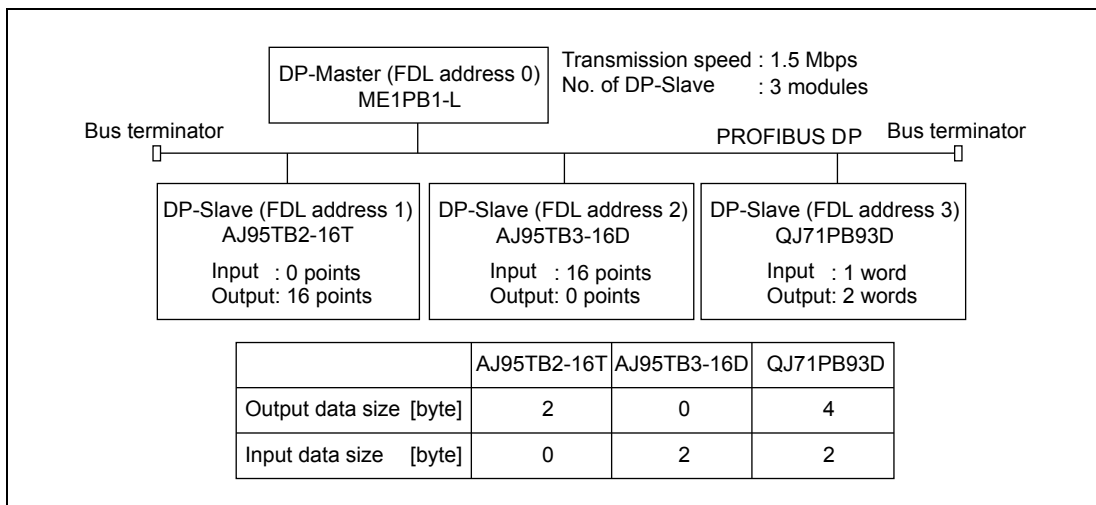

Fig. 3-37: System configuration example

- ① MSI [ms] value: $MSI [ms] = 80 \times 100 [\mu s] = 8.0 [ms]$
- ② $Pt_{(i)}$ [ms] value

Item	DP-Slave		
	AJ95TB2-16T (FDL address 1)	AJ95TB3-16D (FDL address 2)	QJ71PB93D (FDL address 3)
a $Tred_{(i)}$ [ms]	$\{(2 + 9) \times 11\} \times 10^3 / (1.5 \times 10^6) = 0.081$	$\{(0 + 9) \times 11\} \times 10^3 / (1.5 \times 10^6) = 0.066$	$\{(4 + 9) \times 11\} \times 10^3 / (1.5 \times 10^6) = 0.095$
Response time [T_{Bit}] of i-th station	150	150	150
b $Max_Tsd_{r(i)}$ [ms]	$150 \times 10^3 / (1.5 \times 10^6) = 0.1$	$150 \times 10^3 / (1.5 \times 10^6) = 0.1$	$150 \times 10^3 / (1.5 \times 10^6) = 0.1$
c $Tres_{(i)}$ [ms]	$\{(0 + 9) \times 11\} \times 10^3 / (1.5 \times 10^6) = 0.066$	$\{(2 + 9) \times 11\} \times 10^3 / (1.5 \times 10^6) = 0.081$	$\{(2 + 9) \times 11\} \times 10^3 / (1.5 \times 10^6) = 0.081$
$Pt_{(i)}$ [ms] ① + ② + ③	$0.081 + 0.1 + 0.066 = 0.247$	$0.066 + 0.1 + 0.081 = 0.247$	$0.095 + 0.1 + 0.081 = 0.276$

Tab. 3-25: $Pt_{(i)}$ value

- ③ $Tsdi_{(M)}$ [ms] value: Request/response processing time [T_{Bit}] of DP-Master (ME1PB1-L)=200
 $Tsdi_{(M)} [ms] = 200 \times 10^3 / (1.5 \times 10^6) = 0.13$
- ④ Lr [ms] value: $Lr [ms] = 5.50 + 3 \times 150 \times 10^{-3} = 5.95$

Using the values obtained in above ① to ④:

$$\begin{aligned} \sum_{i=1}^3 (Pt_{(i)} + Tsdi_{(M)}) + Lr &= \{(Pt_{(1)} + Tsdi_{(M)}) + (Pt_{(2)} + Tsdi_{(M)}) + (Pt_{(3)} + Tsdi_{(M)})\} + Lr \\ &= \{0.377 \text{ ms} + 0.377 \text{ ms} + 0.406 \text{ ms}\} + 5.95 \text{ ms} \\ &= 1.16 \text{ ms} + 5.95 \text{ ms} \\ &= \underline{7.11 \text{ ms}} \end{aligned}$$

Therefore, the bus cycle time (Bc) value is as follows:

$$\begin{aligned} \text{Max} \left(MSI, \sum_{i=1}^3 (Pt_{(i)} + Tsdi_{(M)}) + Lr \right) &= \text{Max} (8 \text{ ms}, 7.11 \text{ ms}) \\ &= \underline{8 \text{ ms}} \end{aligned}$$



When multiple DP-Masters are used

The bus cycle time (Bc) can be obtained by the following calculation formula when there are multiple DP-Masters on the same network:

$$TBc[ms] = \sum_{i=1}^n Bc(i)$$

n = Number of DP-Masters

BC = Bus cycle time of each DP-Master (refer to fig. 3-36)

The following shows an example where two DP-Masters exist on the same network.

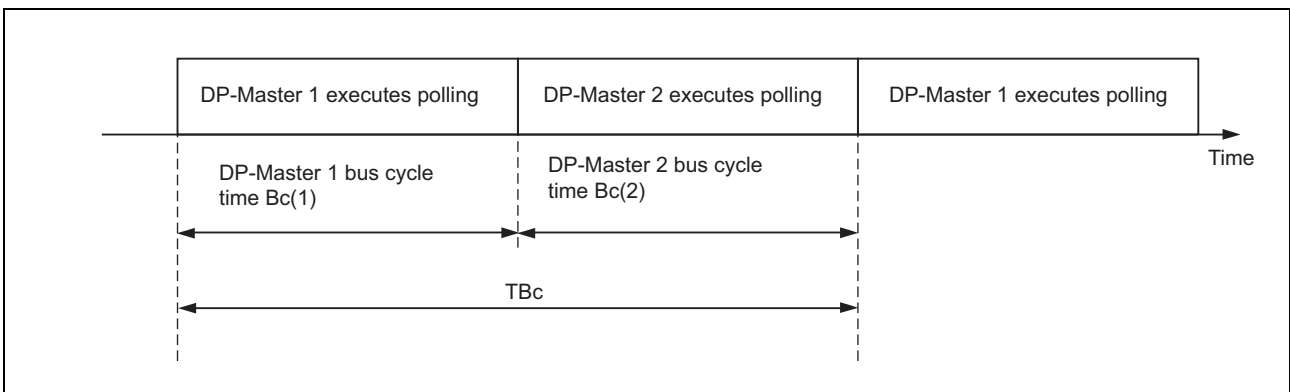

Fig. 3-38: Bus cycle time when two DP-Masters exist on the same network

3.7.2 Transmission delay time

The transmission delay times of the input data and output data vary depending on the data consistency setting.

The calculation formulas for the transmission delay time are shown below.

Note that the following symbols are used in the calculation formulas:

- Bc: Bus cycle time ^①
- Scan: Scan time

^① When multiple DP-Masters exist on the same network, replace Bc with TBc.

When the data consistency function is disabled

When reading/writing I/O data by automatic refresh (data consistency function disabled), the MOV instruction or FROM/TO instruction, the transmission delay time is as shown below.

● Output data delay time

Item	Transmission delay time
Normal value	$Bc \times 1.5$
Max. value	$Bc \times 2$

Tab. 3-26: Output data delay time (data consistency function disabled)

● Input data delay time

Item	Transmission delay time
Normal value	$Scan + Bc$
Max. value	$Scan + Bc \times 2$

Tab. 3-27: Input data delay time (data consistency function disabled)

When the data consistency function is enabled

The reading/writing I/O data by automatic refresh is set (data consistency function enabled) or dedicated instructions, the transmission delay time is as shown below.

● Output data delay time

Item	Condition	Transmission delay time
Normal value	—	$Scan + Bc$
Max. value	$Scan \times 2 \leq Bc$	$Bc \times 3$
	$Scan \times 2 > Bc$	$Scan \times 2 + Bc \times 2$

Tab. 3-28: Output data delay time (data consistency function enabled)

● Input data delay time

Item	Condition	Transmission delay time
Normal value	—	$Scan + Bc$
Max. value	$Scan \times 2 \leq Bc$	$Scan + Bc$
	$Scan \leq Bc < Scan \times 2$	$Scan + Bc \times 2$
	$Scan > Bc$	$Scan \times 3$

Tab. 3-29: Input data delay time (data consistency function enabled)

4 Functions

The following table gives an overview of the functions of the ME1PB1-L.

Function		Description	Reference (section)
PROFIBUS DPV0	I/O data exchange	Up to 125 DP-Slaves can be connected to a single ME1PB1-L, enabling the I/O data exchange of max. 8192 bytes.	4.1.1
	Acquisition of diagnostic and extended diagnostic information	Diagnostic or extended diagnostic information of an error occurred on a DP-Slaves during I/O data exchange can be easily acquired using the buffer memory and I/O signals.	4.1.2
	Global control function	By sending services (SYNC, UNSYNC, FREEZE, UNFREEZE) to each DP-Slave in a group, synchronous control of DP-Slave I/O data is available.	4.1.3
PROFIBUS DPV1	Acyclic communication with DP-Slaves	This function allows data reading/writing to DP-Slaves at any specific timing independently of I/O data exchange.	4.2.1
	Alarm acquisition	This function enables acquisition of up to 8 alarms or status information data that have been generated on any DP-Slave.	4.2.2
PROFIBUS DPV2	Time control over DP-Slaves	This function allows the ME1PB1-L to operate as the time master and set the time of each DP-Slave.	4.3.1
Data swap function		This function swaps the upper and lower bytes in word units when I/O data is sent and received.	4.4
Data consistency function		When I/O data from DP-Slaves are read from or written to the buffer memory, this function prevents the I/O data from being separated and incorrectly mixed. The data consistency function can be set by <ul style="list-style-type: none"> • Automatic refresh setting (intelligent function utility) • Dedicated instructions (BBLKRD, BBLKWR) 	4.5
Output status setting for the case of a CPU stop error		This function sets whether to stop or continue I/O data exchange with DP-Slaves when a CPU stop error occurs on a MELSEC-L series CPU or CC-Link IE station where the ME1PB1-L is mounted.	4.6
Temporary slave reservation function		Without modifying the slave parameter in the intelligent function utility, this function allows the DP-Slave type to be changed to "Reserved station" temporarily.	4.7
Mode change function		It is possible to change the operation mode of the ME1PB1-L through the intelligent function utility or sequence program. The following modes are available: <ul style="list-style-type: none"> • Parameter setting mode (mode 1) • Self-diagnostics mode (mode 2) • Communication mode (mode 3) • Flash ROM clear mode (modes 9 → F → A) 	4.8
			9.5

Tab. 4-1: Functions of the ME1PB1-L

4.1 PROFIBUS DPV0 Functions

4.1.1 I/O Data Exchange

The ME1PB1-L can operate as a DP-Master (Class 1) on the PROFIBUS DP system and perform I/O data exchange with DP-Slaves.

Up to 125 DP-Slaves can be connected to a single ME1PB1-L, enabling the exchange of I/O data up to 8192 bytes.

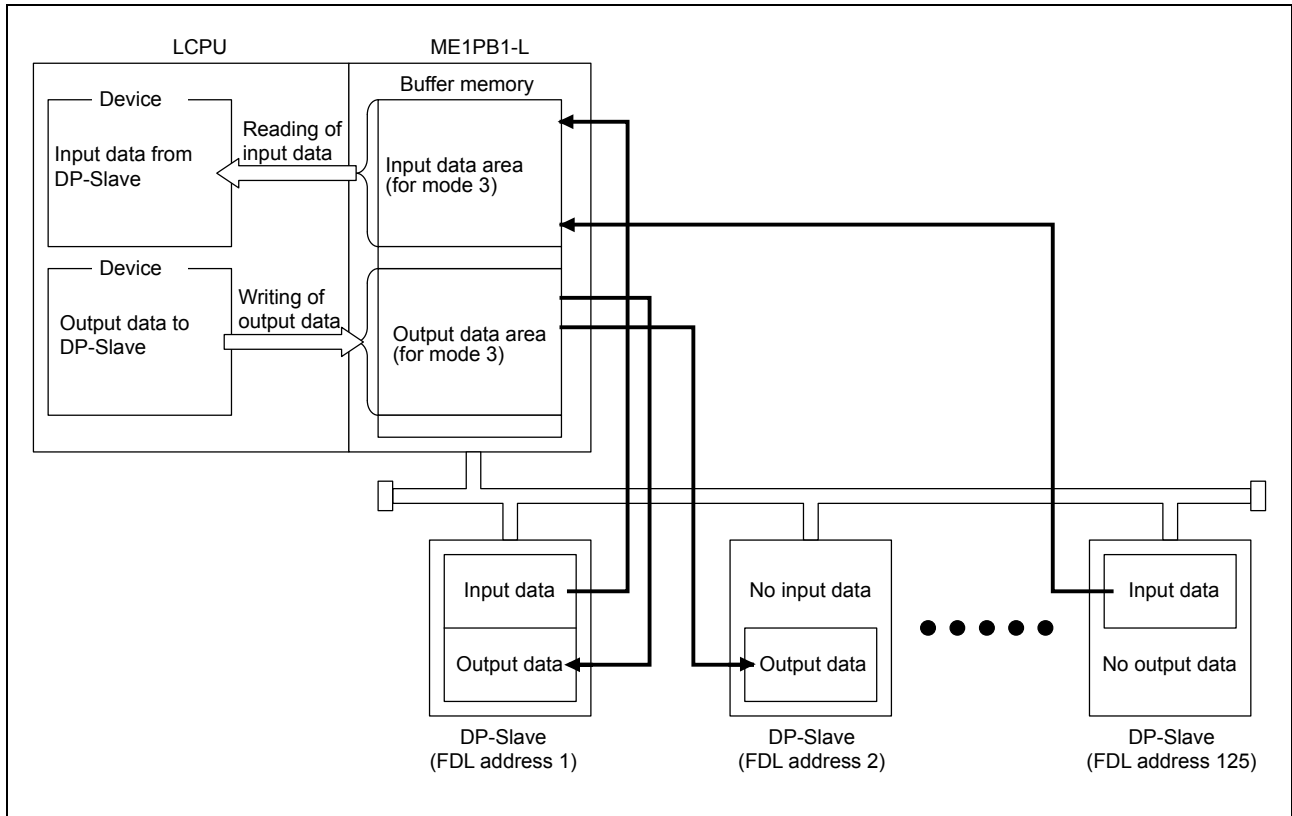

Fig. 4-1: I/O data exchange

Reading/writing I/O data

- Buffer memory

Read or write I/O data from the following buffer memory in the ME1PB1-L:

- Input data: Input data area (for mode 3) (Un\G6144 to Un\G10239)
- Output data: Output data area (for mode 3) (Un\G14336 to Un\G18431)

- Read/write methods

Read or write I/O data (from the buffer memory) to devices in the LCPU by the following methods.

Read/write methods	Setting location	Data consistency function
Automatic refresh	Intelligent function utility	Available
Dedicated instructions (BBLKRD, BBLKWR)	Sequence program	
MOV or FROM/TO instructions	Sequence program	Not available

Tab. 4-2: Read/write methods for I/O data

Starting and stopping I/O data exchange

- ① Write the initial value of the output data to the Output data area (for mode 3) (Un\G14336 to Un\G18431).
- ② Turn ON the Data exchange start request signal (Yn0).
- ③ When I/O data exchange is started after turning ON the Data exchange start request signal (Yn0), the Data exchange start completed signal (Xn0) turns ON.
- ④ Input data from DP-Slaves are stored in the Input data area (for mode 3) (Un\G6144 to Un\G10239).
- ⑤ Turning OFF the Data exchange start request signal (Yn0) turns OFF the Data exchange start request signal (Xn0), and I/O data exchange is stopped.

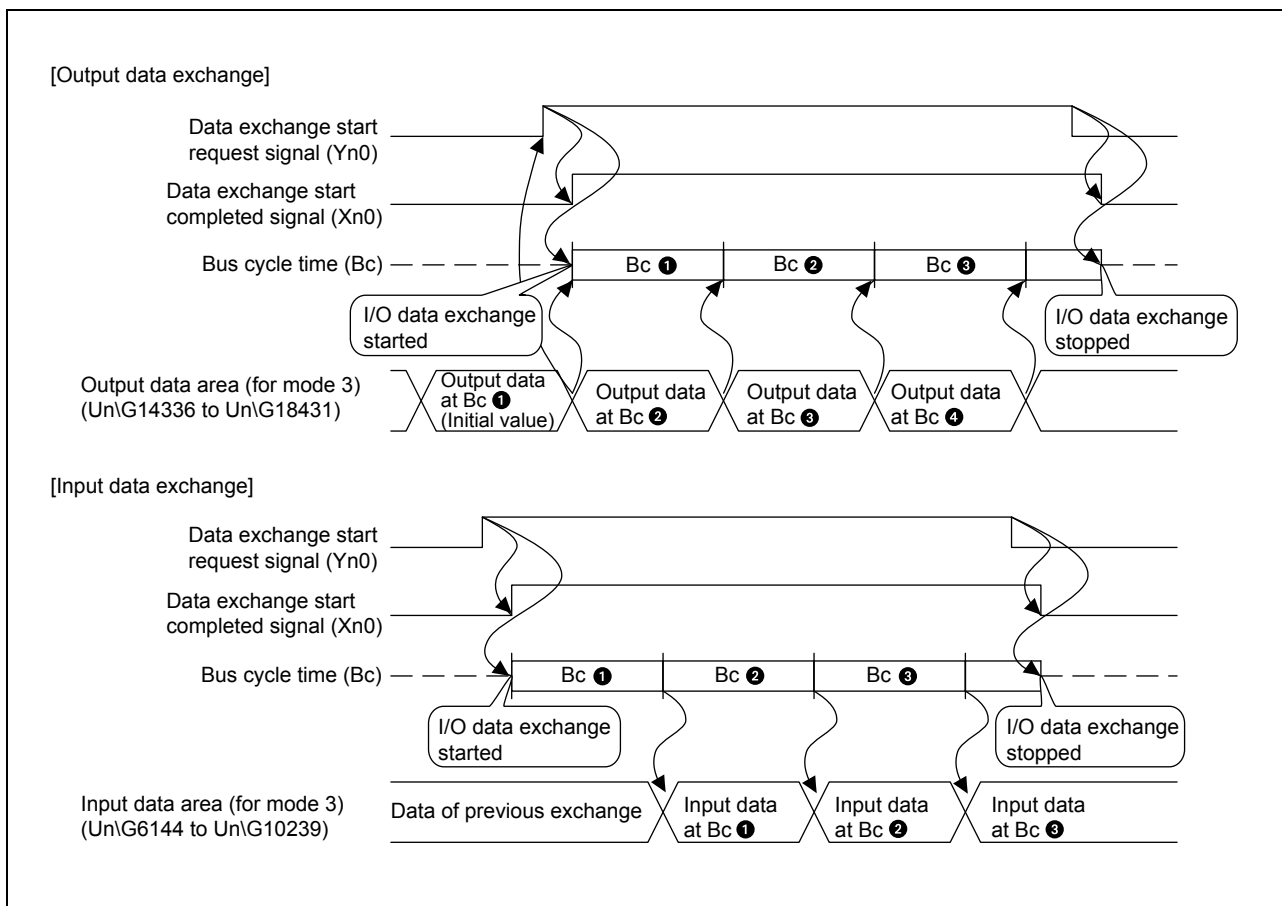

Fig. 4-2: I/O data exchange processing

NOTE

For program examples of the I/O data exchange, refer to section 7.1

4.1.2 Acquisition of Diagnostic and/or Extended Diagnostic Information

Diagnostic and/or extended diagnostic information of an error occurred on DP-Slaves during I/O data exchange can be easily acquired using buffer memory and I/O signals. The cause of errors occurring on DP-Slaves can be checked on the ME1PB1-L from the diagnostic and/or extended diagnostic information.

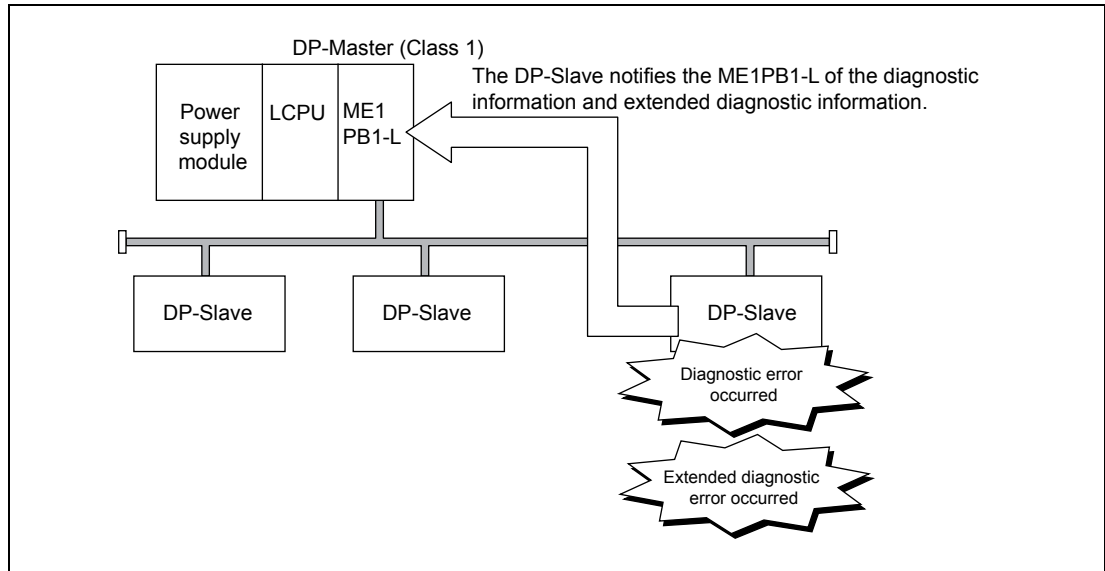

Fig. 4-3: Acquisition of diagnostic and/or extended diagnostic information

Procedure for acquiring diagnostic and/or extended diagnostic information

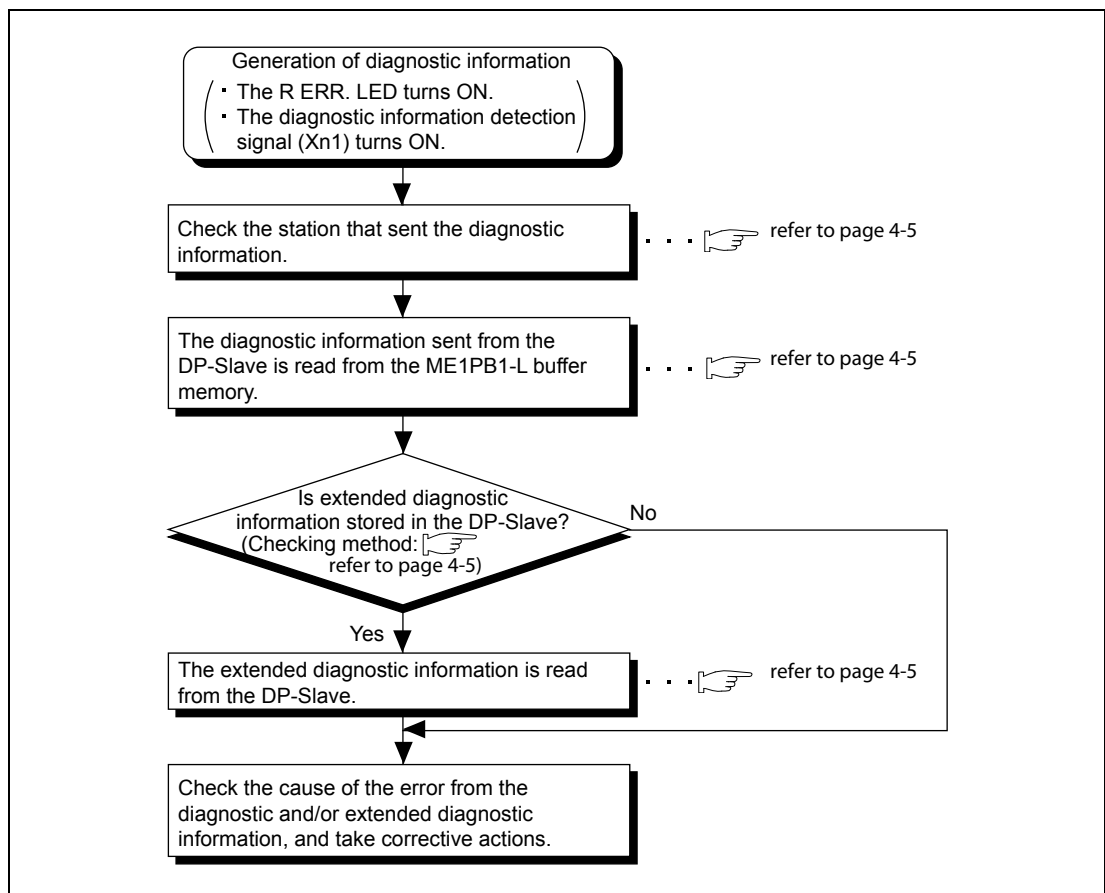

Fig. 4-4: Acquisition of diagnostic and/or extended diagnostic information

Checking the station generating diagnostic information

The data showing where diagnostic information of each DP-Slave is occurring are stored in the Slave status area (Diagnostic information detection) (Un\G23056 to Un\G23064). The bit corresponding to the station that sent the diagnostic information turns ON in the Each station's diagnostic status area (Un\G23057 to Un\G23064).

Acquiring diagnostic information

The diagnostic information of DP-Slaves is stored in the buffer memory of the ME1PB1-L. Read the diagnostic information from the following buffer memory:

Diagnostic information area (for mode 3) (Un\G23072 to Un\G23321)

Acquiring extended diagnostic information

● Checking the station generating extended diagnostic information

For whether extended diagnostic information is stored in any of DP-Slaves or not, check each DP-Slave's Status 1 information that is stored in the Diagnostic information area (for mode 3) (Un\G23072 to Un\G23321).

In the case of the 1st DP-Slave, check Bit b11 of buffer memory address 23073 (5A21H).

● Acquiring extended diagnostic information from DP-Slaves

Perform the following procedure to acquire extended diagnostic information:

- ① Write the FDL address of the DP-Slave, from which extended diagnostic information is read, to the Extended diagnostic information read request area (Un\G23456).
- ② Turn ON the Extended diagnostic information read request signal (Yn6).
- ③ When reading of the extended diagnostic information is completed, the Extended diagnostic information read response signal (Xn6) turns ON, and the extended diagnostic information is stored in the Extended diagnostic information read response area (Un\G23457 to Un\G23583).
- ④ Check the read extended diagnostic information, and turn OFF the Extended diagnostic information read request signal (Yn6).

NOTES

The latest extended diagnostic information that occurred during I/O data exchange is stored in the buffer memory of the ME1PB1-L.

To check the latest extended diagnostic information, read it from the following buffer memory area: Extended diagnostic information area (for mode 3) (Un\G23328 to Un\G23454)

For program examples on acquisition of extended diagnostic information, refer to section 7.2

4.1.3 Global Control Function

By multicasting (broadcasting) data, the ME1PB1-L can simultaneously control I/O data of each DP-Slave in a specified group.

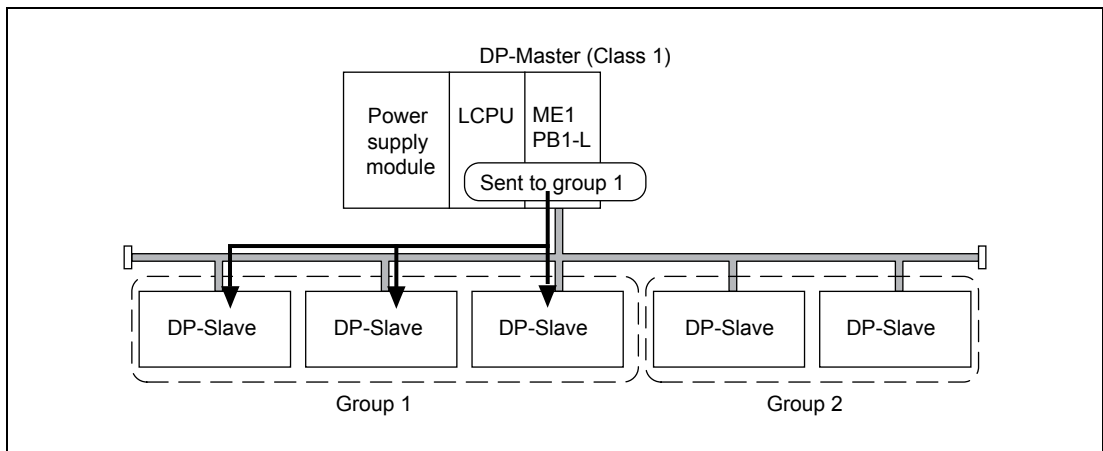

Fig. 4-5: The global control function is used to send data to the slaves of group 1

Global control services SYNC and UNSYNC

● SYNC

This service starts the SYNC (output synchronization) mode. In the SYNC mode, the output status is refreshed every time a DP-Slave receives the SYNC service.

If no SYNC service is received, the output status is held.

● UNSYNC

This service ends the SYNC (output synchronization) mode.

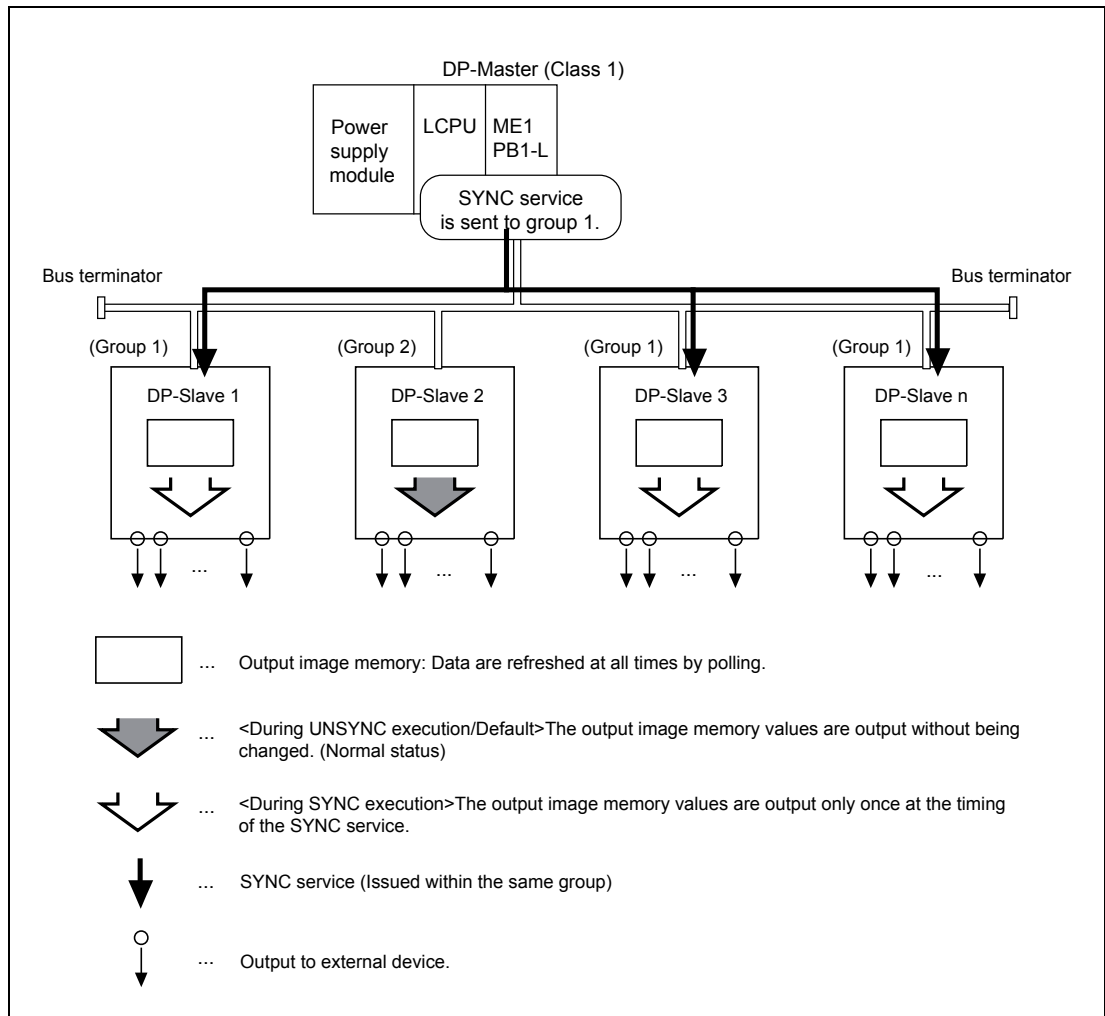

Fig. 4-6: Global control services SYNC and UNSYNC

Global control services FREEZE and UNFREEZE

● FREEZE

This service starts the FREEZE (input synchronization) mode. In the FREEZE mode, the input status is refreshed every time a DP-Slave receives the FREEZE service.

If no FREEZE service is received, the input status is held.

● UNFREEZE

This service ends the FREEZE (input synchronization) mode.

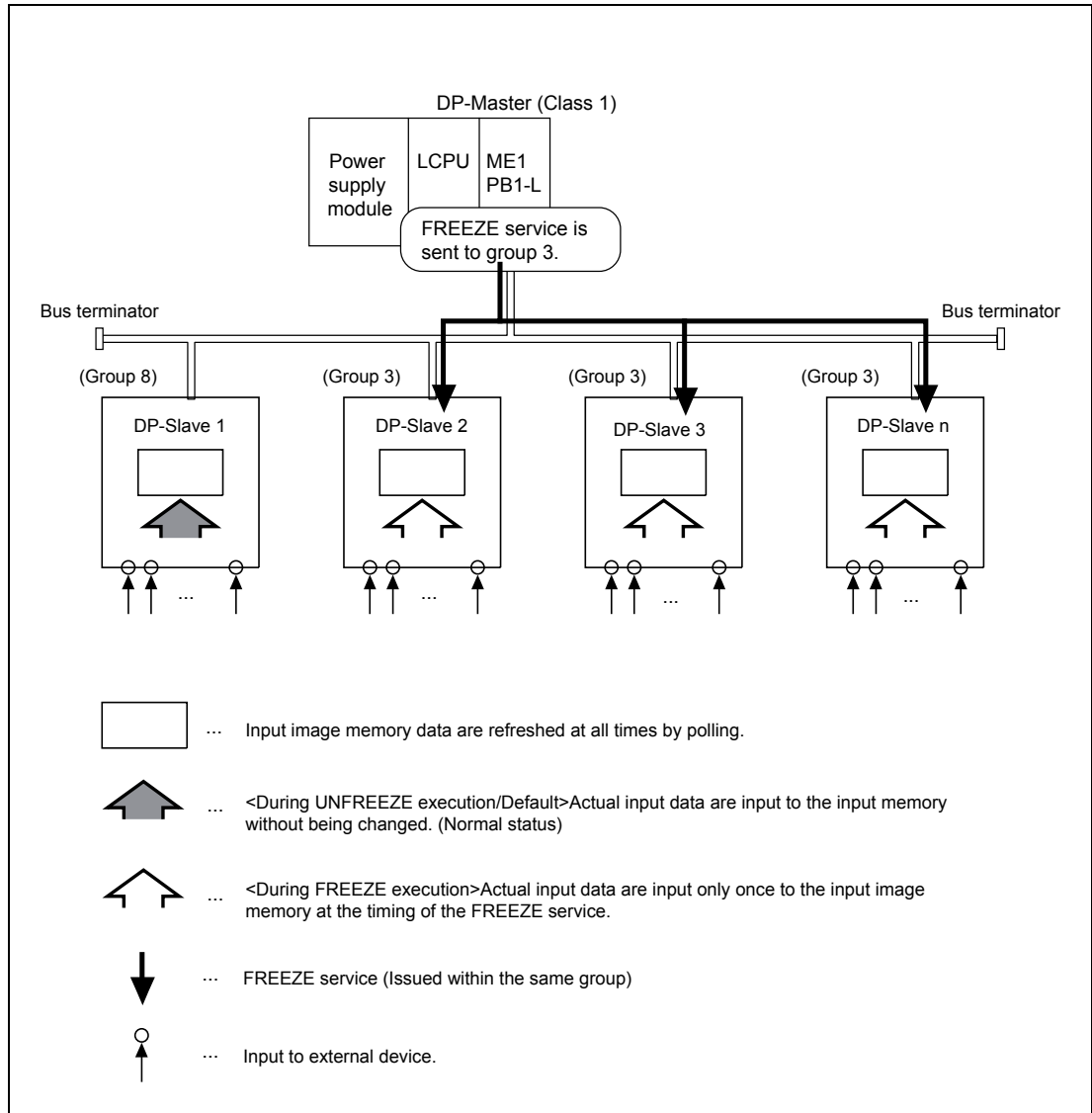

Fig. 4-7: Global control services FREEZE and UNFREEZE

Group setting

Set groups using the slave parameter ("Slave Settings" window in the intelligent function utility).

Up to eight groups, groups 1 to 8, can be set.

Multiple groups can also be assigned to a single DP-Slave.

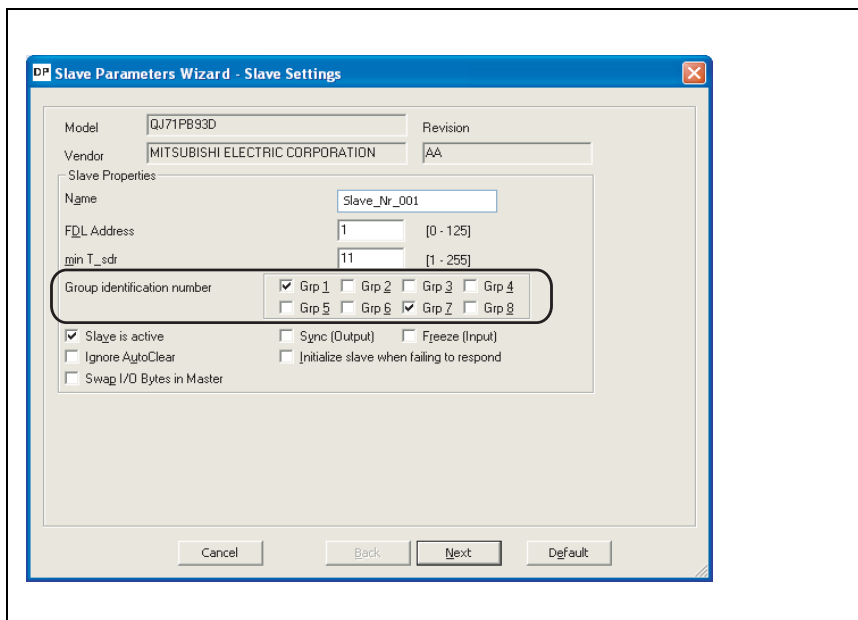

Fig. 4-8: Group settings

Executing the global control function

Execute the global control function by the following procedure:

- ① Write the service to be sent and the target group to the Global control area (Un\G2081).
- ② Turn ON the Global control request signal (Yn4).
- ③ When global control processing is completed, the Global control completed signal (Xn4) turns ON. If the processing failed, the Global control failed signal (Xn5) turns ON.
- ④ After confirming completion of the global control, turn OFF the Global control request signal (Yn4).

NOTES

To execute the global control function to all DP-Slaves (including DP-Slaves for which group No. is not set), set 0s to all bits from b15 to b8 in the Global control area (Un\G2081).

For program examples on the global control function, refer to section 7.3

4.2 PROFIBUS DPV1 Functions

NOTES

To utilize PROFIBUS DPV1 functions, use a DP-Slave that supports the PROFIBUS DPV1. For details, refer to the manual for the DP-Slave.

When using the PROFIBUS DPV1 function, set a "Min. slave interval" value greater than the bus cycle time calculated from Pt, Tsd and Lr. (Refer to section 3.7)

If the "Min. slave interval" is less than the value calculated from Pt, Tsd and Lr, the processing of the PROFIBUS DPV1 function may take time.

4.2.1 Acyclic Communication with DP-Slaves

This function allows data reading/writing to DP-Slaves at any specific timing independently of I/O data exchange.

Up to eight requests are executable.

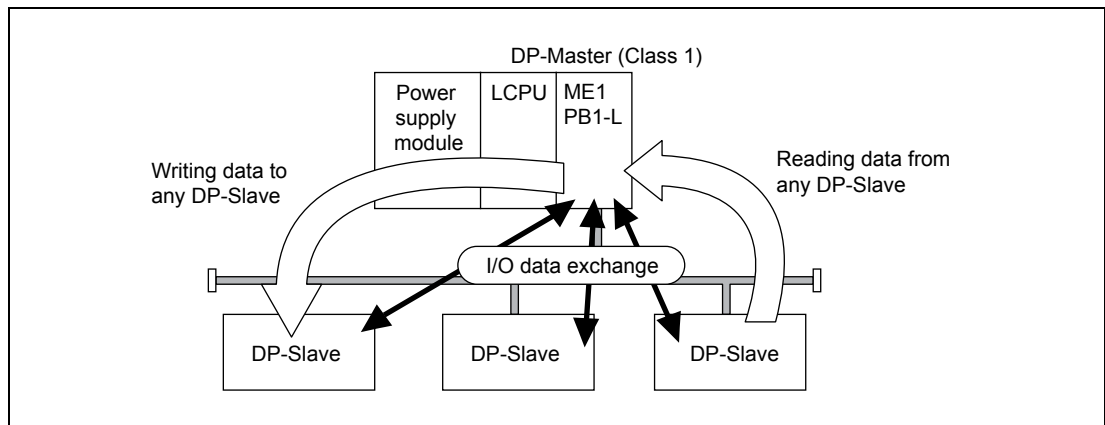

Fig. 4-9: Acyclic communication

Services available on the ME1PB1-L

In acyclic communications, there are two types of services: Class1 and Class2 services.

The services available on the ME1PB1-L differ depending on whether or not the target DP-Slave is performing I/O data exchange.

Target DP-Slave	Available service	
	Class1 service	Class2 service
DP-Slave performing I/O data exchange	●	●
DP-Slave not performing I/O data exchange	○	●

Tab. 4-3: Available services

●: Available, ○:Not available

Whether the DP-Slave supports each service or not can be checked in the GSD file. For details, refer to the manual for the DP-Slave.

● Class1 services

When executing a Class1 service, verify in advance that the bit corresponding to the target DP-Slave is ON in the Slave status area (Normal communication detection) (Un\G23040 to Un\G23047).

Service name	Description
READ (Class1_SERVICE)	Reads data from any specified DP-Slave. ①
WRITE (Class1_SERVICE)	Writes data to any specified DP-Slave. ①

Tab. 4-4: Available services (Class1 services)

① The data that can be read or written by READ or WRITE services vary depending on the DP-Slave to be used. For details, refer to the manual for the DP-Slave.

● Class2 services

Connect the line to the DP-Slave by the INITIATE service, and execute the READ and/or WRITE services.

To end the acyclic communication, disconnect the line from the DP-Slave by the ABORT service.

When executing a Class2 service to a DP-Slave that is exchanging I/O data, verify in advance that the bit corresponding to the DP-Slave is ON in the Slave status area (Normal communication detection) (Un\G23040 to Un\G23047).

When executing a Class2 service to a DP-Slave that is not exchanging I/O data, verify in advance that the DP-Slave has been completely activated.

For details, refer to the manual for the DP-Slave.

Service name	Description
INITIATE (Class2_SERVICE)	Establishes a line connection with any specified DP-Slave.
ABORT (Class2_SERVICE)	Disconnects a line connection from any specified DP-Slave.
READ (Class2_SERVICE)	Reads data from a DP-Slave connected to the line by the INITIATE service. ①
WRITE (Class2_SERVICE)	Writes data to a DP-Slave connected to the line by the INITIATE service. ①

Tab. 4-5: Available services (Class2 services)

① The data that can be read or written by READ or WRITE services vary depending on the DP-Slave to be used. For details, refer to the manual for the DP-Slave.

Executing acyclic communication

Execute the acyclic communication by the following procedure:

- ① Write the request instruction to be executed to the Acyclic communication request area (Un\G23809 to Un\G24832).
- ② Turn ON (1) the bit corresponding to the request instruction No. in the Acyclic communication request execution instruction area (Un\G23808).
- ③ When the ME1PB1-L accepts the acyclic communication request instruction, the acceptance status bit in the Acyclic communication request result area (Un\G25120) turns ON (1).
- ④ When execution of the acyclic communication is completed, the completion status bit in the Acyclic communication request result area (Un\G25120) turns ON (1), and the execution result is stored in the Acyclic communication response area (Un\G25121 to Un\G26144).

NOTES

- When a communication fails in Class 1 services due to cable fault or influence of noise (refer to section 5.5.2), being exchanged with DP-Slaves may be initialized. (Inputs and outputs are turned OFF.)
- For program examples on the acyclic communication, refer to section 7.4

4.2.2 Alarm Acquisition

This function enables acquisition of up to 8 alarms or status information data that have been generated on any DP-Slave.

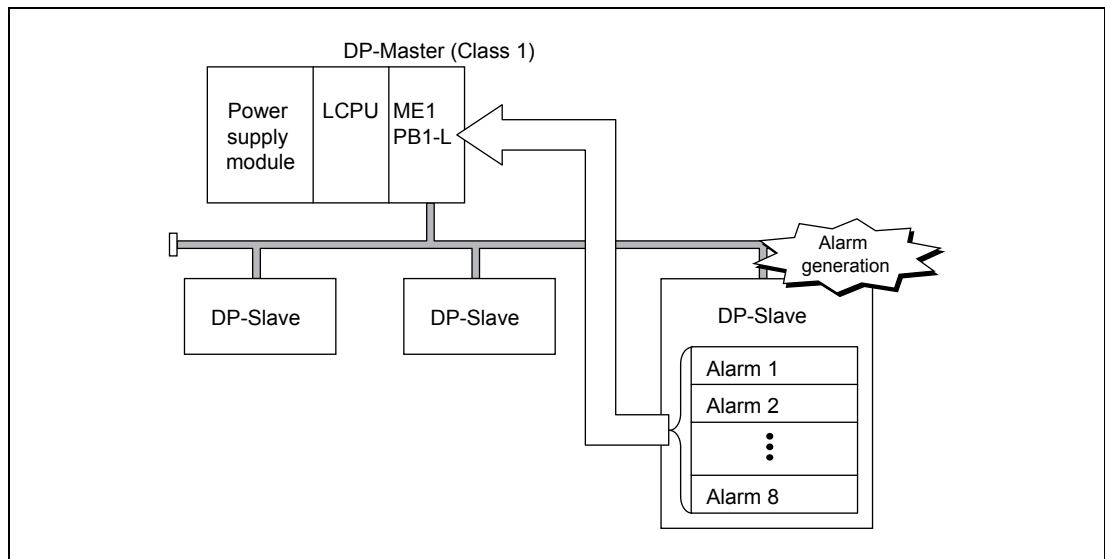

Fig. 4-10: Acquisition of alarms

Requests available on the ME1PB1-L

There are the following two ways for acquiring alarms:

- using the Alarm read request (without ACK) and Alarm ACK request
- and using the Alarm read request (with ACK).

Whether the DP-Slave supports this function or not can be checked in the GSD file. For details, refer to the manual for the DP-Slave.

- Alarm read request (without ACK), Alarm ACK request

Use these requests when a certain time may be required to return ACK after reading an alarm from a DP-Slave (e.g. when taking corrective actions for the DP-Slave error).

The Alarm ACK request enables ACK to be returned for each read-out alarm.

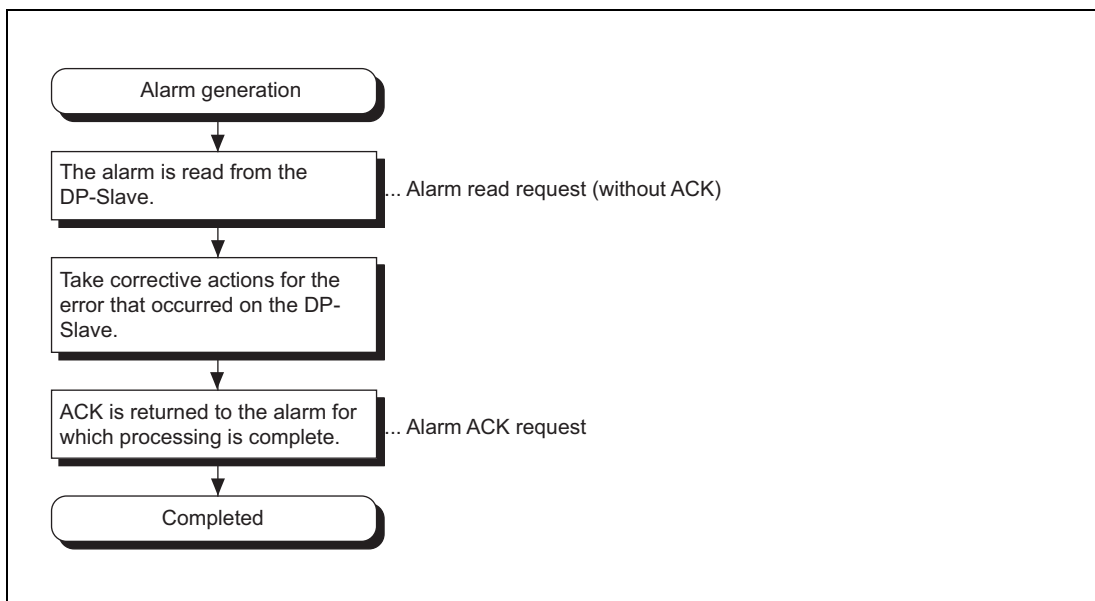

Fig. 4-11: Procedure using alarm read request (without ACK) and alarm ACK request

- Alarm read request (with ACK)

This request automatically sends ACK after reading an alarm.

ACK is returned in response to all read-out alarms.

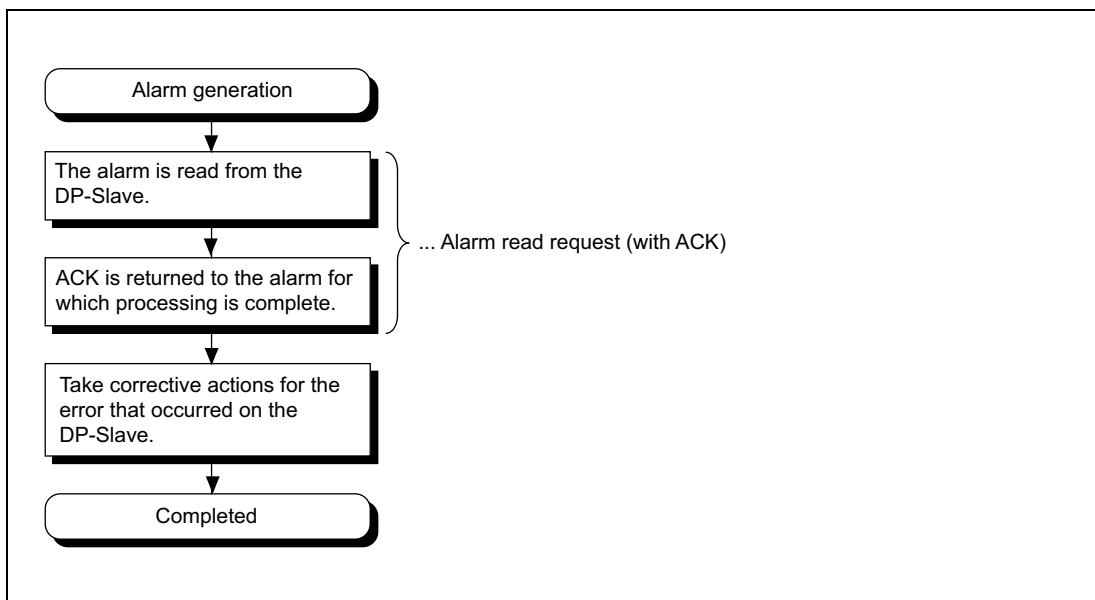

Fig. 4-12: Procedure using alarm read request (with ACK)

Executing alarm acquisition

Execute alarm acquisition by the following procedure:

- ① In the Slave status area (Alarm detection) (Un\G26416 to Un\G26424), identify the DP-Slave where an alarm is occurring.
- ② Write the request data to the DP-Slave into the Alarm request area (Un\G26432 to Un\G26434).
- ③ Turn ON the Alarm read request signal (Y(n+1)8).
- ④ When alarm reading is completed, the read result is stored in the Alarm response area (Un\G26446 to Un\G26768) and the Alarm read response signal (X(n+1)8) turns ON.
- ⑤ Check the alarm stored in the Alarm response area (Un\G26446 to Un\G26768), and turn OFF the Alarm read request signal (Y(n+1)8).

NOTE

For program examples on the alarm acquisition, refer to section 7.5

4.3 PROFIBUS DPV2 Functions

NOTES

To utilize PROFIBUS DPV2 functions, use a DP-Slave that supports the PROFIBUS DPV2.

For details, refer to the manual for the DP-Slave.

When using the PROFIBUS DP2 function, set a "Min. slave interval" value greater than the bus cycle time calculated from Pt, TsdI and Lr. (Refer to section 3.7)

If the "Min. slave interval" is less than the value calculated from Pt, TsdI and Lr, the processing of the PROFIBUS DPV2 function may take time.

4.3.1 Time Control over DP-Slaves

This function allows the ME1PB1-L to operate as the time master and set the time of each DP-Slave.

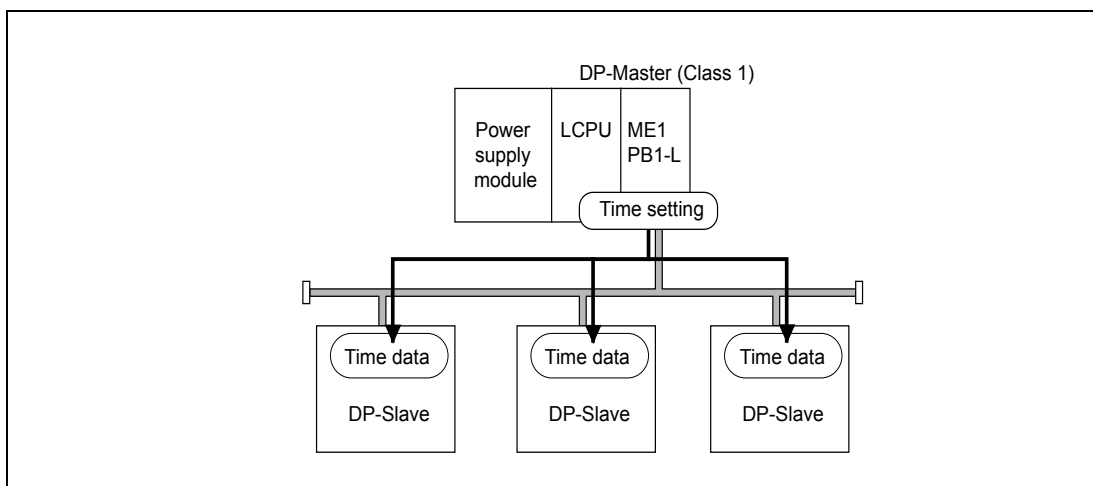

Fig. 4-13: Time setting for all slaves

Requests available on the ME1PB1-L

For whether the DP-Slave supports this function or not, refer to the manual for the DP-Slave.

- Requests for writing time data

Request name	Description
Time data write request	Sets the year, month, day, hour, minute and second, and writes the time data.
Time data write request (UTC format)	Writes time data in UTC seconds (year + month + day + hour + minute + second). Example: The set value, 9DFF4400H represents "January 1 st in 1984, 00:00:00".

Tab. 4-6: Request for writing time data

● Request for reading time data

The time data read request is used to read the time data written to a DP-Slave by another time master out to the ME1PB1-L.

This request can be used when two or more time masters exist on the same network.

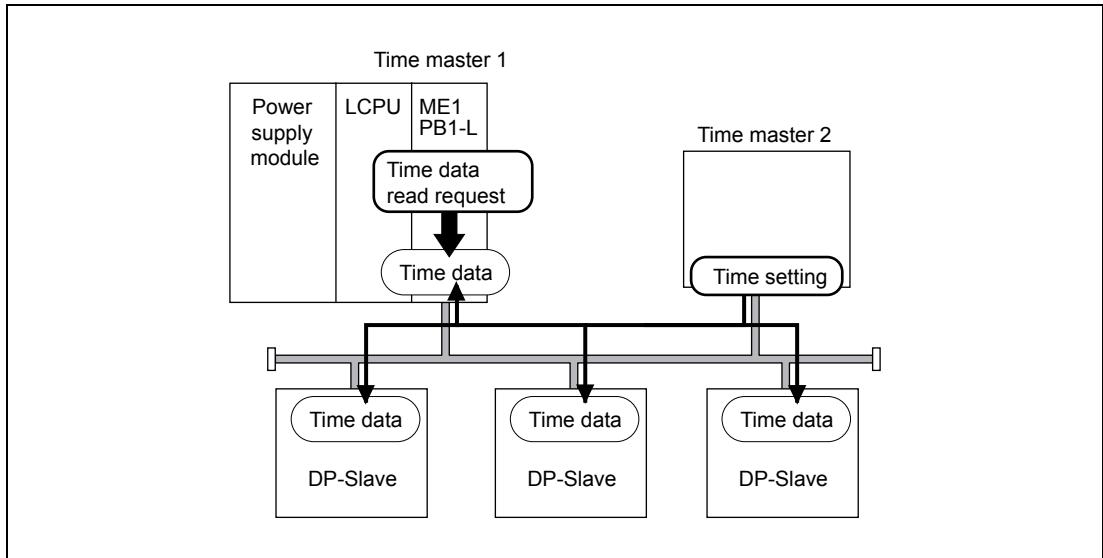

Fig. 4-14: Time data read request

Executing time control function

Execute the time control function by the following procedure:

- ① Write request data to the Time control setting request area (Un\G26784 to Un\G26792).
- ② Turn ON the Time control start request signal (Y(n+1)9).
- ③ When the time control is completed, the execution result is stored in the Time control setting response area (Un\G26800 to Un\G26812), and the Time control start response signal (X(n+1)9) turns ON.
- ④ Check the execution result stored in the Time control setting response area (Un\G26800 to Un\G26812), and turn OFF the Time control start response signal (X(n+1)9).

NOTE

For program examples on the time control function, refer to section 7.6

4.4 Data Swap Function

This function swaps the upper and lower bytes in word units when I/O data is sent and received. Use this function for DP-Slaves whose word structure is different (upper and lower bytes are reversed) from that of the ME1PB1-L.

This function enables you to swap upper and lower bytes to exchange I/O data without the need to create a special sequence program for the swapping.

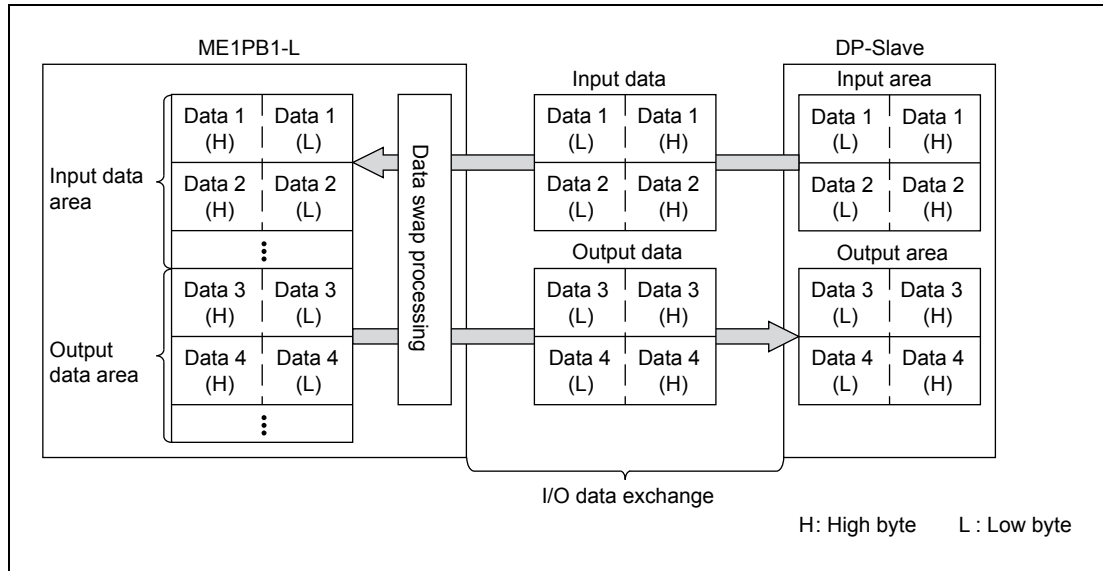

Fig. 4-15: Data are swapped between ME1PB1-L and input or output devices

4.4.1 Data swap setting

Configure the data swap setting using the slave parameter ("Slave Settings" window in the intelligent function utility). Data swap setting must be made for each DP-Slave.

Select the "Swap I/O Bytes in Master" checkbox to enable the swap setting for a DP-Slave.

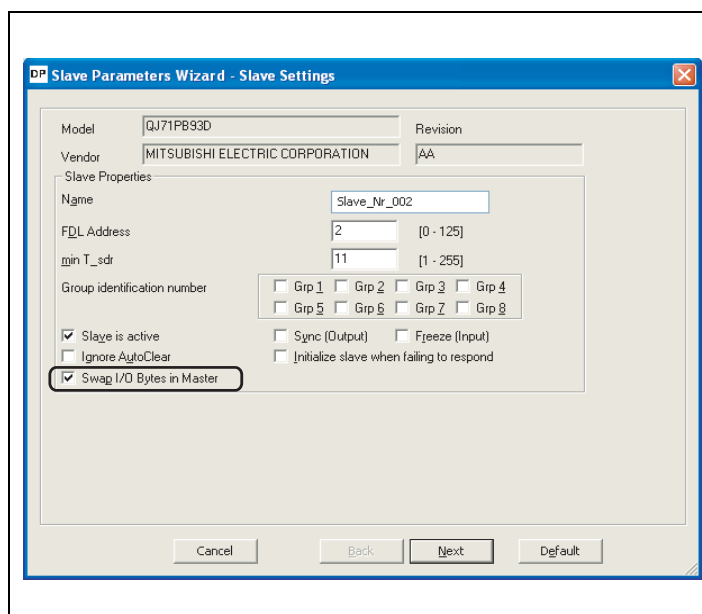

Fig. 4-16: Data swap setting

4.4.2 Invalidating or validating data swap setting

For DP-Slaves that handle data whose word structure is the same as that of the ME1PB1-L, invalidate the data swap setting.

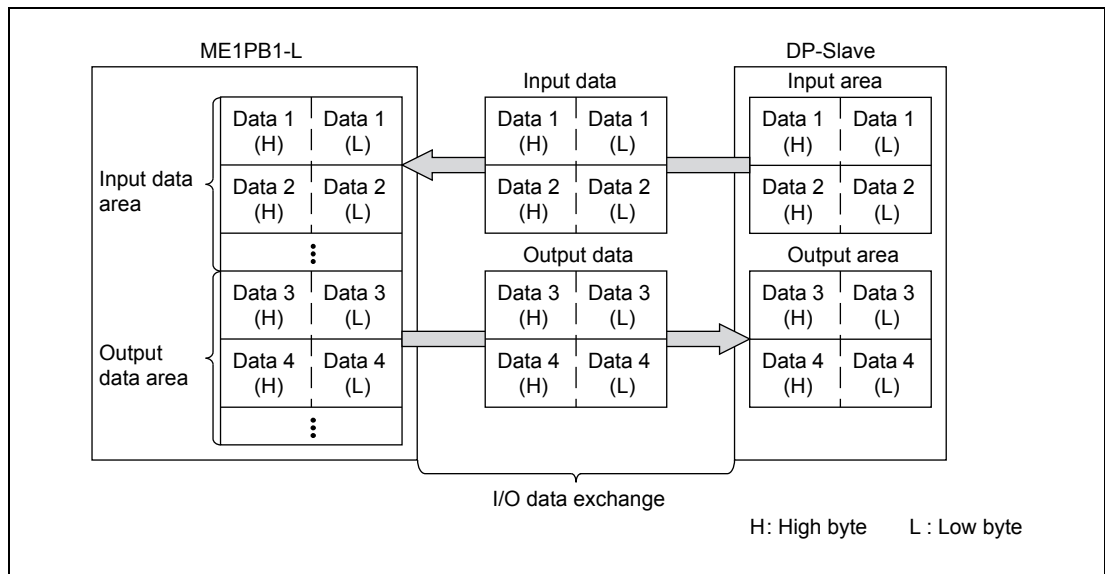

Fig. 4-17: When invalidating the data swap setting

For DP-Slaves that handle data whose word structure is the reverse of the ME1PB1-L, validate the data swap setting.

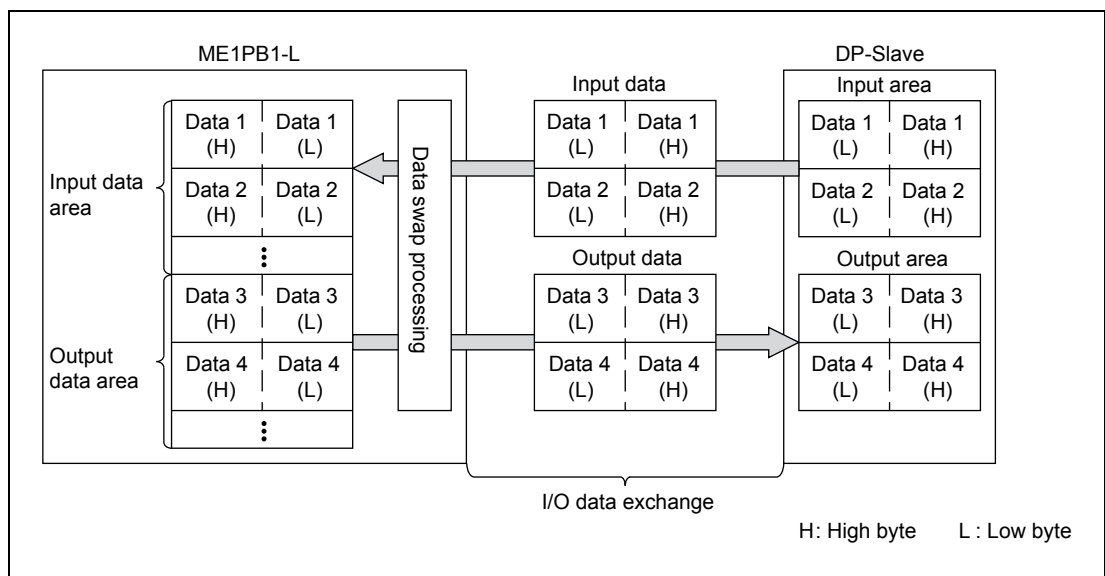

Fig. 4-18: When validating the data swap setting

4.5 Data Consistency Function

When I/O data from DP-Slaves are read from or written to buffer memory, this function prevents the I/O data from being separated and incorrectly mixed.

4.5.1 I/O data consistency function

The PROFIBUS DP bus cycle and LCPU sequence scan are performed asynchronously.

Because of this, when the LCPU reads input data in the buffer memory during input data transfer from a DP-Slave to the buffer memory, the original data may be divided generating inconsistency in the input data. (The same applies to output data.)

The following shows an example of data inconsistency when data are read from the LCPU during the input data transfer from a DP-Slave to the buffer memory.

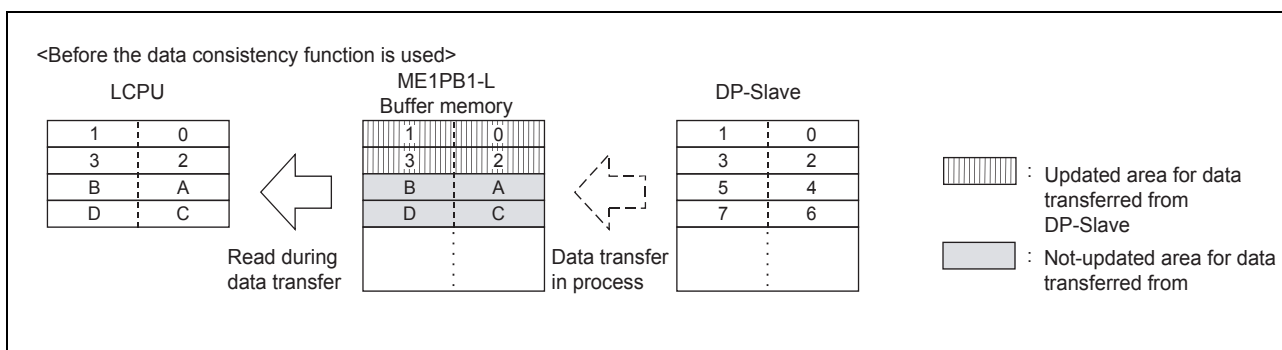

Fig. 4-19: Example of input data inconsistency

When the data consistency function is enabled, it makes reading from the LCPU wait until data transfer from a DP-Slave to the ME1PB1-L buffer memory (Input data area) is completed, and the reading is executed upon completion of the data transfer.

Alternatively, the ME1PB1-L stands by for data transfer to DP-Slaves until writing from the LCPU to the ME1PB1-L buffer memory (Output data area) is completed, and executes the data transfer upon completion of the writing.

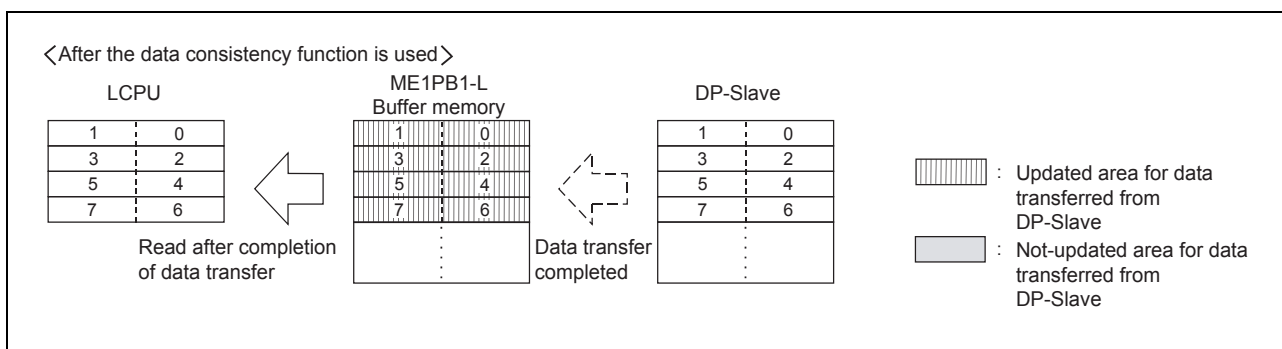

Fig. 4-20: Example of input data consistency

4.5.2 How to prevent data inconsistency

The data consistency function can be used by either of the following methods.

- Data consistency function by automatic refresh

To set automatic refresh, click the **Next** button in the "Master Settings" window of the intelligent function utility.

To use the data consistency function by automatic refresh, select the **Consistency** checkbox.

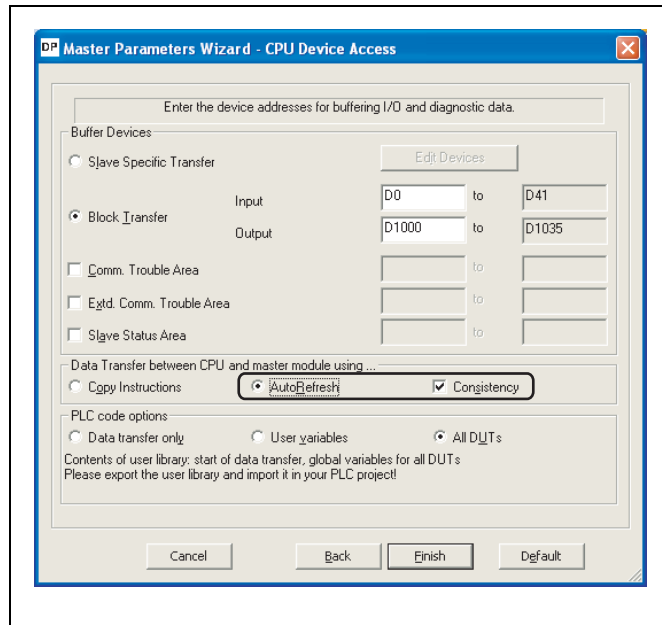

Fig. 4-21: Automatic refresh setting in the intelligent function utility

NOTE

For the automatic refresh setting method, refer to section 6.6.2.

- Data consistency function by dedicated instructions

Use the BBLKRD (read) and BBLKWR (write) instructions as dedicated instructions for reading/writing ME1PB1-L buffer memory to execute the data consistency function.

For details on dedicated instructions, refer to Chapter 8.

NOTE

For program examples on the I/O data exchange using dedicated instructions, refer to section 7.1.2

4.5.3 Precautions

- Transmission delay time when the data consistency function is used

When the data consistency function is used, the transmission delay time between the LCPU and DP-Slaves increases because the time waiting for read/write from the LCPU or data transfer from/to DP-Slaves arises. (Refer to section 3.7)

The data consistency function can be disabled in the automatic refresh setting. If this function is unnecessary, disable it.

- When the data consistency function is enabled in the automatic refresh setting

Dedicated instructions are not executable. (They are not processed.). Dedicated instructions are executable if the data consistency function is disabled in the automatic refresh setting.

- MOV or FROM/TO instruction

The data consistency function is not usable when data refresh are performed between the LCPU and the ME1PB1-L buffer memory by the MOV or FROM/TO instruction.

4.6 Output Status Setting for the Case of a CPU Stop Error

This function sets whether to stop or continue I/O data exchange with DP-Slaves when a CPU stop error occurs on a LCPU or CC-Link IE station where the ME1PB1-L is mounted.

4.6.1 Output status setting for the case of a CPU stop error

On the programming software, set the output status for the case where a CPU stop error occurs. Set desired output status in the intelligent function module detailed settings after setting the I/O assignments of the ME1PB1-L.

- I/O assignment setting

Startup procedure: **Parameters** → **PLC parameter** → **I/O assignment**

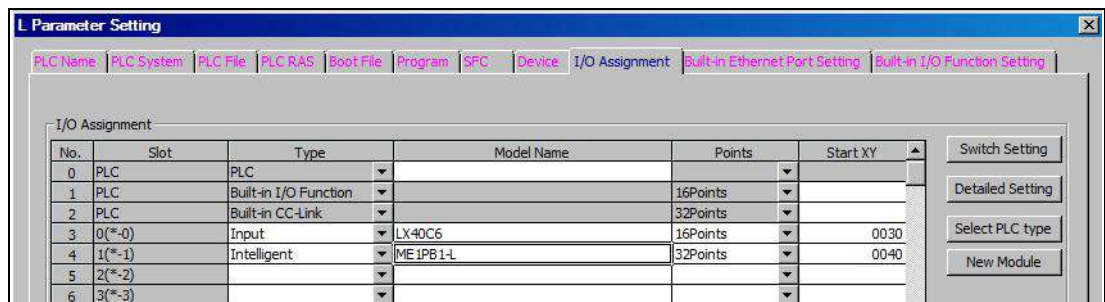

Fig. 4-22: I/O assignment in the PLC

- Intelligent function module detailed settings

Startup procedure: **Parameters** → **PLC parameter** → **I/O assignment** → Button **Detailed setting**

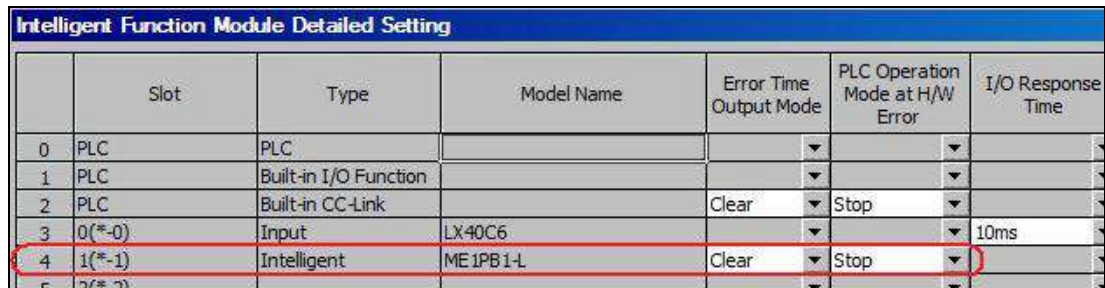

Fig. 4-23: Output status setting for the case of a CPU stop error

4.6.2 Output status for the case of a CPU stop error

- When "Error time output mode" is set to "Clear"

The ME1PB1-L stops I/O data exchange when a CPU stop error occurs. Due to stop of I/O data exchange, no output data is sent to DP-Slaves.

Input data received from a DP-Slave before stop of I/O data exchange are held in the buffer memory of the ME1PB1-L.

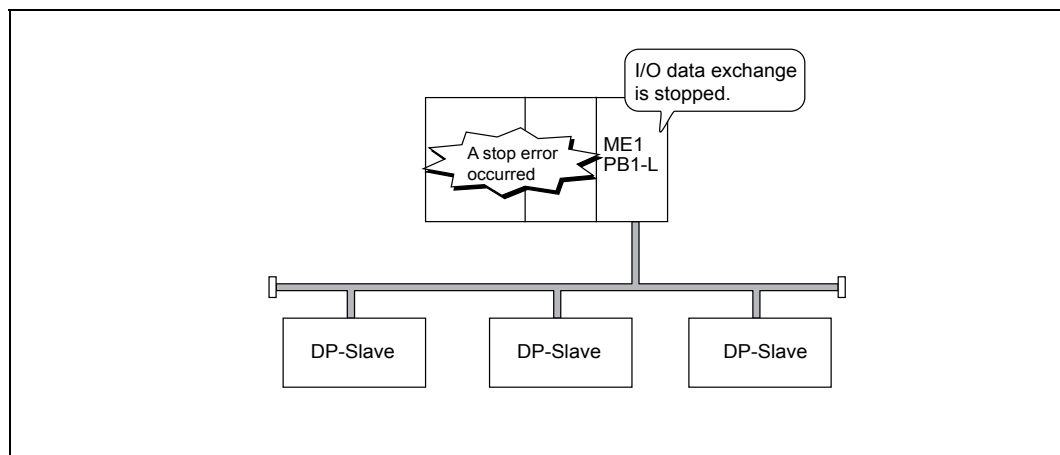

Fig. 4-24: When "Error time output mode" is set to "Clear"

NOTE

Whether or not output data are output from each DP-Slave to external devices after stop of I/O data exchange differs depending on the setting of the DP-Slave.

For details, refer to the manual for the DP-Slave.

- When "Error time output mode" is set to "Hold"

The ME1PB1-L continues I/O data exchange when a CPU stop error occurs. The data before occurrence of the CPU stop error are held and they are sent to the DP-Slaves.

Input data received from DP-Slaves updates the buffer memory of the ME1PB1-L.

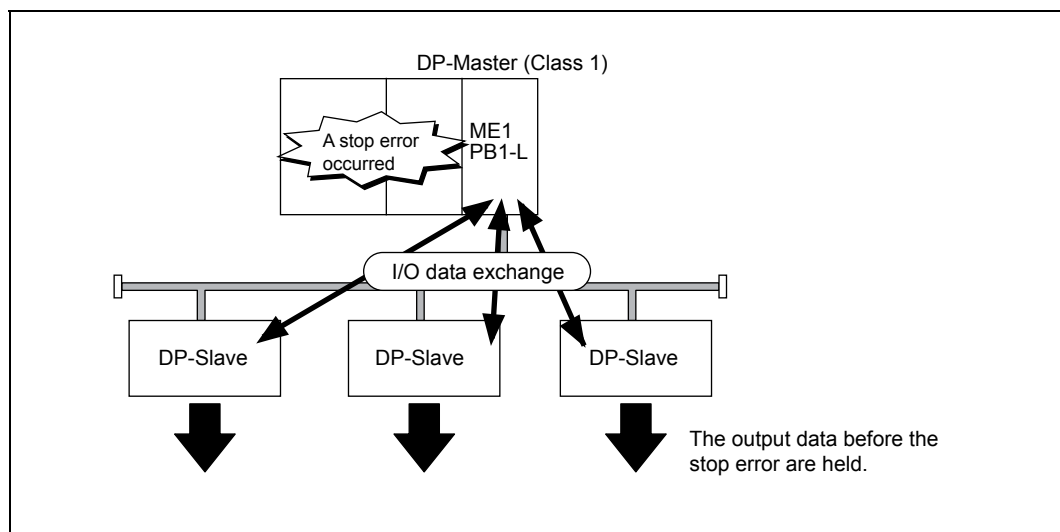

Fig. 4-25: When "Error time output mode" is set to "Hold"

4.7 Temporary Slave Reservation Function

Without modifying the slave parameter using the intelligent function utility, this function allows the DP-Slave type to be changed to "Reserved station" temporarily.

Since there is no need to change slave parameters, changing a DP-Slave setting to a reserved station is easy.

4.7.1 DP-Slaves that can be changed to temporarily reserved stations

Normal DP-Slaves can be changed to temporarily reserved stations. Changing reserved stations (DP-Slaves set as reserved stations with slave parameters) to normal DP-Slave status is not allowed.

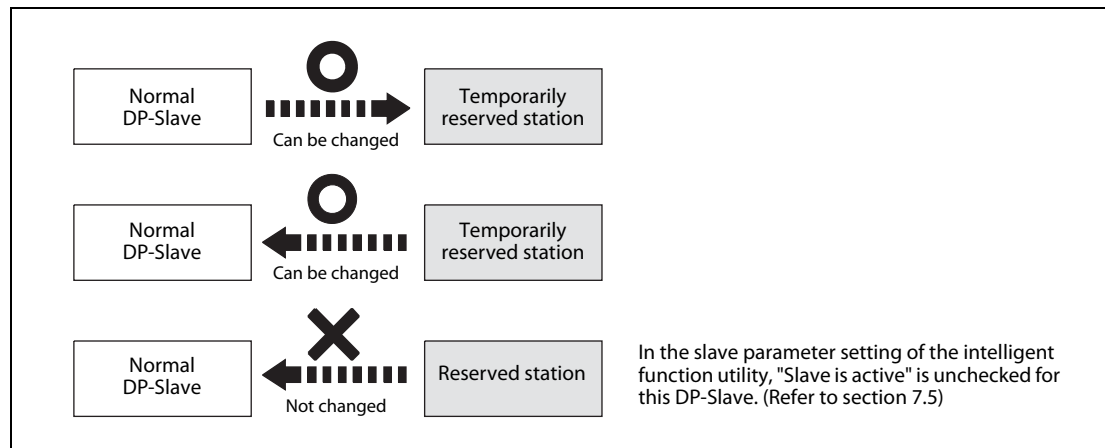

Fig. 4-26: DP-Slaves that can be changed to temporarily reserved stations

4.7.2 Temporary slave reservation specification and cancellation

Use the temporary slave reservation function by the following procedures:

Specification method

- ① Set Normal DP-Slaves, which are to be changed to Temporary slave reservations, in the temporary slave reservation request area (Un\G23608 to Un\G23615). (Refer to section 3.6.13)
- ② Turn ON the Data exchange start request signal (Yn0).
- ③ Upon completion of the temporary slave reservation specification, the results are stored in the temporary slave reservation status area (Un\G23600 to Un\G23607), and the Data exchange start completed signal (Xn0) turns ON. (Refer to section 3.6.5)

Cancel method

- ① Turn OFF the Data exchange start request signal (Yn0).
- ② In the temporary slave reservation request area (Un\G23608 to Un\G23615), cancel the DP-Slaves specified as temporary slave reservation.
- ③ Turn ON the Data exchange start request signal (Yn0).
- ④ Upon completion of the temporary slave reservation cancellation, the results are stored in the temporary slave reservation status area (Un\G23600 to Un\G23607), and the Data exchange start completed signal (Xn0) turns ON.

NOTE

For program examples on the temporary slave reservation function, refer to section 7.7

4.8 Mode Change Function

The operation mode of the ME1PB1-L can be changed by the sequence program.

Mode No.	Mode	Description
1	Parameter setting mode	The mode to write parameter from the intelligent function utility. In the case of no parameter stored in Flash ROM, the module moves to this mode.
2	Self-diagnostics mode	The mode for Self-diagnostics. In this mode, the following items can be checked: ROM, Timer, MPU, DRAM, 2port RAM, Swap port. Refer to section 5.4 for the details.
3	Communication mode	The mode for PROFIBUS communication (DPV1/DPV2).

Tab. 4-7: Operation modes of the ME1PB1-L

Procedure to change the operation mode

- ① Write the number of the desired mode to the Operation mode change request area (Un\G2255).
- ② Turn ON the Operation mode change request signal (Y(n+1)1).
- ③ The result is stored to Operation mode change result area (Un\G2256).

In the case of success, also the operation mode in Current operation mode area (Un\G2254) is updated.

Additionally the Flash ROM storage mode area (Un\G2259) is updated in the case of register to the Flash ROM.

- ④ The Operation mode change completed signal (X(n+1)1) is turned ON.

The Local FDL address display area (Un\G2257) is updated when mode 3 is selected.

NOTES

When the ME1PB1-L detects the Operation mode change request signal (Y(n+1)1) ON while communicating the I/O communication is forced to disconnect.

While executing acyclic communication, time control function or reading alarms, the mode change function cannot be used.

The procedure to clear the flash ROM of the ME1PB1-L is described in section 9.5

5 Settings and Procedures before System Operation

This chapter explains the procedures for connecting the ME1PB1-L to PROFIBUS DP, wiring and other information.

5.1 Implementation and Installation

This section provides the handling precautions, from unpacking to installation of the ME1PB1-L.

For details on the implementation and installation of the ME1PB1-L, refer to the user's manual (Hardware design, maintenance and inspection) for the CPU module used.

5.1.1 Handling precautions

The following are precautions for handling the ME1PB1-L as a unit.

- Do not drop the module case or subject it to heavy impact since it is made of resin.
- Do not remove the printed-circuit board of each module from its case.
This may cause a failure in the module.
- Be careful not to let foreign objects such as wire chips enter the module during wiring. In the event any foreign object enters, remove it immediately.
- A protective film is attached to the top of the module to prevent foreign matter, such as wire chips, from entering the module during wiring.
Do not remove the film during wiring. Remove it for heat dissipation before system operation.
- Tighten the screws within the following torque ranges.

Screw location	Tightening torque range
PROFIBUS cable connector screw (#4 - 40UNC screws)	0.20 to 0.28 Nm

Tab. 5-1: Screw tightening torque

5.2 Procedures Before System Operation

The following diagram illustrates the procedure before system operation.

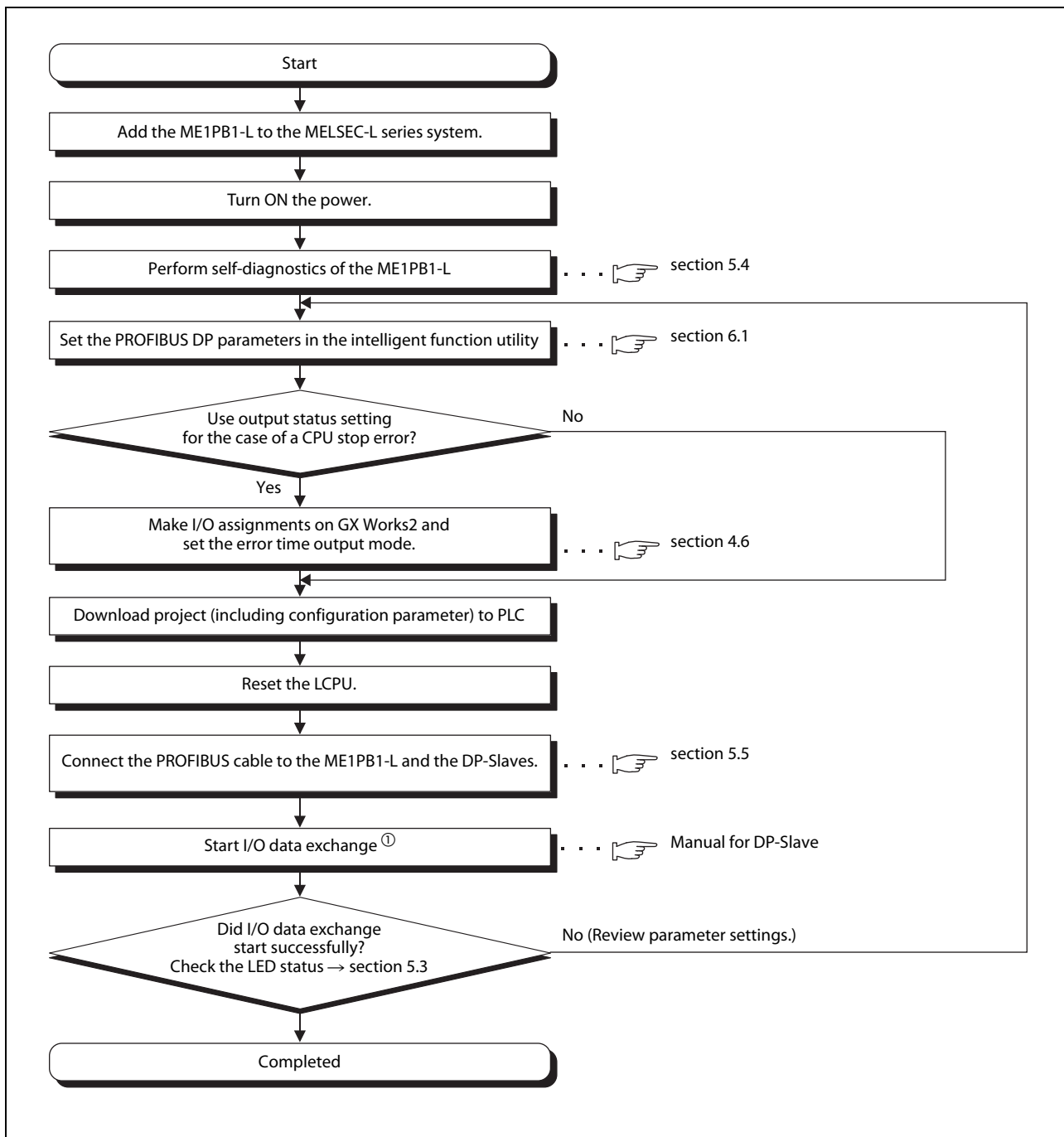

Fig. 5-1: Procedures before system operation

- ① Start I/O data exchange by either of the following methods:
- Turn ON the Data exchange start request signal (Yn0)
 - Start it from the intelligent function utility

5.3 Part Names and Settings

This section explains the names and settings of each part of the ME1PB1-L.

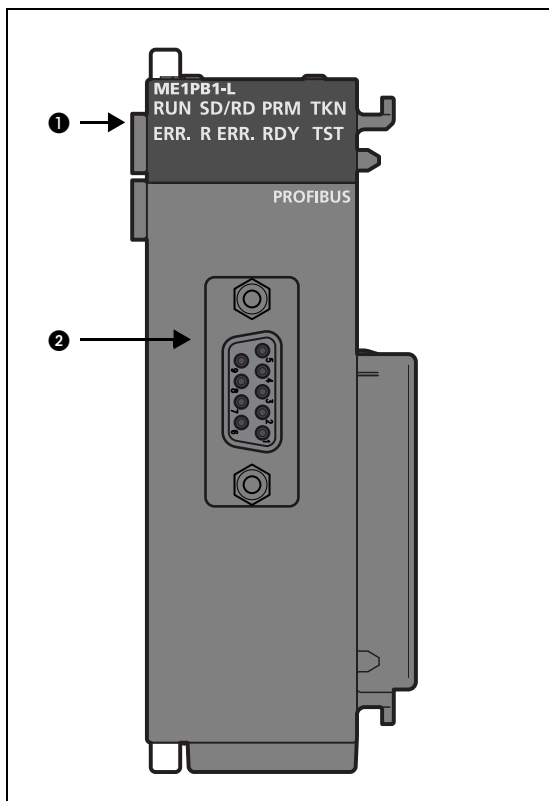

Fig. 5-2:
ME1PB1-L appearance

No.	Name	Description
①	Indicator LEDs	These LEDs indicate the operation status of the ME1PB1-L. For details, refer to section 5.3.1.
②	PROFIBUS interface connector (D-sub 9-pin female connector)	This connector connects the PROFIBUS cable to the ME1PB1-L.

Tab. 5-2: Names of parts

5.3.1 Indicator LEDs

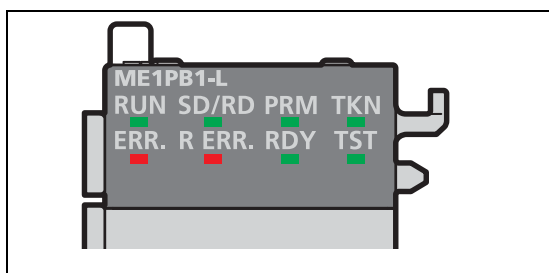

Fig. 5-3:
Indicator LEDs

LED	Status	Description	Reference (section)
RUN	ON	Normally operating	—
	OFF	Hardware error (watchdog timer error) or power failure	9.1
SD/RD	ON	Exchanging I/O data ^① or during acyclic communication ^②	4.1.1
	Flashing		4.2.1
	OFF	Not communicating with DP-Slave	—
PRM	ON	Operating in Parameter setting mode (mode 1)	6.2
	Flashing	The written parameters are invalid.	9.1
	OFF	Operating in operation mode other than Parameter setting mode (mode 1)	6.2
TKN	ON	Token being passed ^③	—
	Flashing		—
	OFF	No token passing ^③	—
ERR.	ON	An error has occurred.	9.1
	OFF	Normally operating	—
R ERR.	ON	A communication error has occurred.	3.6.6
	OFF	No communication error	—
RDY	ON	Ready to communicate or communication being performed	—
	OFF	Not ready to communicate or no communication	—
TST	ON	Executing self-diagnostics or flash ROM initialization	5.4 9.5
	Flashing	Executing self-diagnostics	5.4
	OFF	Not executing self-diagnostics or flash ROM initialization	—

Tab. 5-3: Indicator LEDs

- ① The LED flashes at intervals based on the value set in "Data control time" in Master Parameters.
- ② The LED flashes at the time of request or response in acyclic communication.
- ③ The LED status during token passing varies depending on the number of DP-Masters within the same network and the transmission speed setting, as shown in the following table.

No. of DP-Masters within the same network	Transmission speed	
	19.2 kbps or less	93.75 kbps or more
1	ON	
More than 1	Flashing	ON or OFF

Tab. 5-4: TKN LED status

5.4 Self-diagnostics

The self-diagnostics of the ME1PB1-L performs a unit test on the ME1PB1-L. It takes about 15 seconds to complete the self-diagnostics.

5.4.1 Self-diagnostics execution procedure

The following shows how to execute the self-diagnostics.

- Set the operation mode of the ME1PB1-L to Self-diagnostics mode (mode 2) by the following method:
 - Store 02H in the Operation mode change request area (Un\G2255).
 - Turn on the Operation mode change request signal (Y(n+1)1).
- When the operation mode is set to Self-diagnostics mode (mode 2), the self-diagnostics is automatically started.

During execution of self-diagnostics, the TST LED is ON or flashing.

Upon completion of the self-diagnostics, the LEDs on the ME1PB1-L change as shown below, storing the test result to the Offline test status area (Un\G2258).

- When normally completed: The TST LED turns OFF.
- When failed: The TST and ERR. LEDs are ON.

5.4.2 Execution result of self-diagnostics

TST LED OFF (When normally completed)

When the TST LED turns OFF after execution of self-diagnostics, this indicates a normal completion.

TST and ERR. LEDs ON (When failed)

If the TST and ERR. LEDs are ON after execution of self-diagnostics, this indicates that the diagnostics failed.

Check the value stored in the Offline test status area (Un\G2258), and retry the self-diagnostics.

If the diagnostics fails again, a ME1PB1-L hardware error is probable.

Please check the value currently stored in the Offline test status area (Un\G2258), and consult your local Mitsubishi representative, explaining a detailed description of the problem.

Values that may be stored in the Offline test status area (Un\G2258)

Any of the following values is stored in the Offline test status area (Un\G2258) after execution of self-diagnostics.

Stored value	Description
07FFH	Normal completion
F700H	ROM check test error
F701H	Timer test error
F702H	MPU test error
F703H	RAM test error
F704H	2-port RAM test error
F705H	Swap port test error

Tab. 5-5: Self-diagnostics result

5.5 Wiring

This section explains the pin assignments of the PROFIBUS interface connector on the ME1PB1-L, the PROFIBUS cable wiring specifications, bus terminator and other information.

5.5.1 Pin assignments of the PROFIBUS interface connector

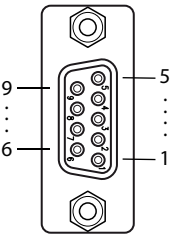
PROFIBUS Interface connector	Pin no.	Signal code	Name	Description	Wire color
	1	—	—	Open	—
	2	—	—	Open	—
	3	B/B'	RxD/TxD-P	Receive/send data -P	Red
	4	—	—	Open	—
	5	C/C'	DGND ^①	Data Ground	—
	6	—	VP ^①	Voltage +	—
	7	—	—	Open	—
	8	A/A'	RxD/TxD-N	Receive/send data -N	Green
	9	—	—	Open	—

Tab. 5-6: Pin assignments of the PROFIBUS interface connector (D-sub 9-pin female connector) on the ME1PB1-L

^① Signal used to connect the bus terminator.

5.5.2 PROFIBUS cable

Use a PROFIBUS cable that meets the following specifications (Type A (IEC 61158-2) compliant).

Item	Transmission line
Applicable cable	Shielded twisted pair cable
Impedance	135 to 165 Ω (f=3 to 20 MHz)
Capacity	Less than 30 pF/m
Conductor resistance	Less than 110 Ω /km
Cross-sectional area	0.34 mm ² or more (22AWG)

Tab. 5-7: Specifications of the PROFIBUS cable

Applicable connector

Use a D-sub 9-pin male connector for the PROFIBUS cable.

The applicable screw size is #4-40 UNC.

Wiring specifications

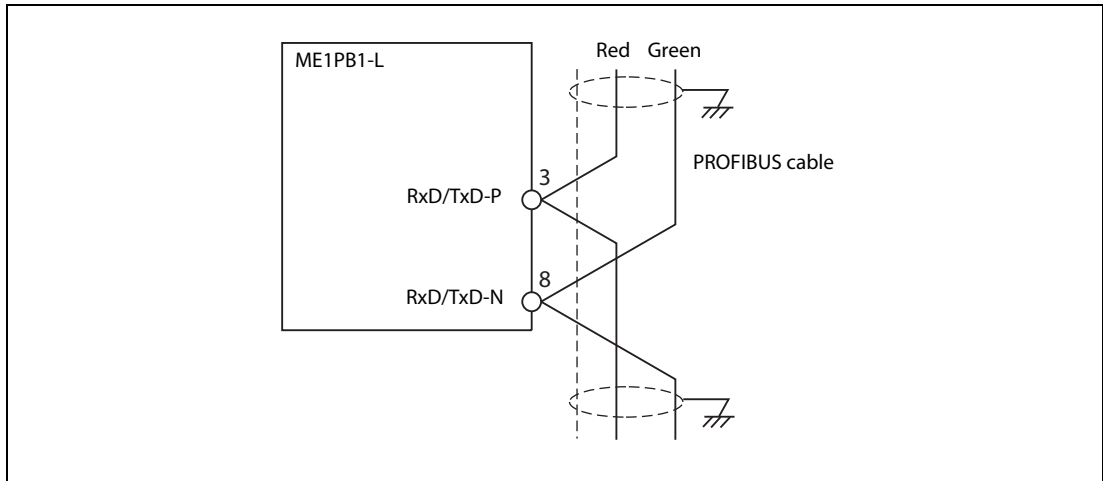

Fig. 5-4: Connection of the PROFIBUS cable

Wiring specifications for bus terminator

When the ME1PB1-L is a terminal station, it is recommended to use a connector with built-in bus terminator resistors that meets the following wiring specifications.

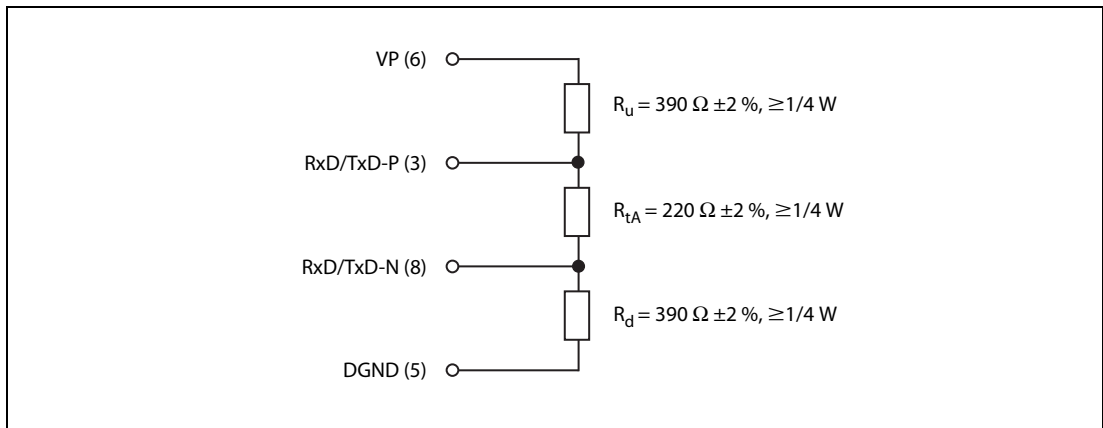

Fig. 5-5: Wiring specifications for bus terminator

PROFIBUS equipment

The PROFIBUS cables, connectors and other PROFIBUS equipment must be purchased or obtained at user's discretion.

For details on PROFIBUS equipment, access the following website.

PROFIBUS International: <http://www.profibus.com/>

5.5.3 Wiring precautions

As one of the requirements to give full play to ME1PB1-L's functions and make up the system with high reliability, it is necessary to have an external wiring unsusceptible to an influence of noise.

The following gives the precautions for external wiring of the ME1PB1-L.

Communication cable wiring

Do not install the PROFIBUS cable together with the main circuit, power lines and/or load carrying wires for other than the programmable controller, or bring them close.

Doing so may cause the ME1PB1-L to be affected by noise and surge induction.

Wirings from programmable controller and I/O modules

Keep the PROFIBUS cable away from I/O module cables as much as possible.

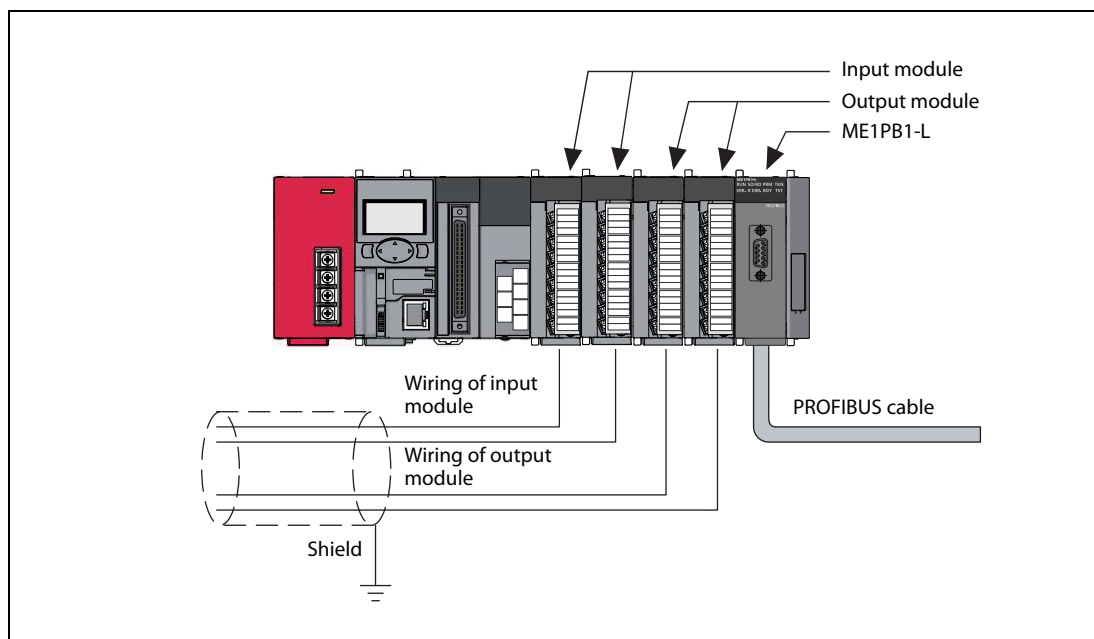

Fig. 5-6: Programmable controller wiring

Grounding

For use of the ME1PB1-L, ground the FG and LG terminals of the programmable controllers power supply module.

5.6 Intelligent Function Utility (GX Works2)

The programming software GX Works2 allows the quick and easy parameter setting for intelligent function modules like the ME1PB1-L.

Programming is reduced because the initial setting and automatic data exchange between PLC CPU and ME1PB1-L can be configured on the screen. In addition, the "switches" of intelligent function modules can be set easily.

5.6.1 Addition of a new module to the project

To add a new intelligent function module to a project, click on **Intelligent Function Module** in the Project Navigation window. After a right click, select **New Module**.

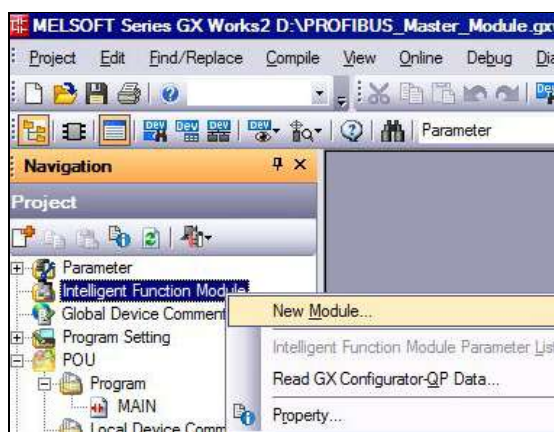

Fig. 5-7: Addition of a new intelligent function module

The window **New Module** is displayed.

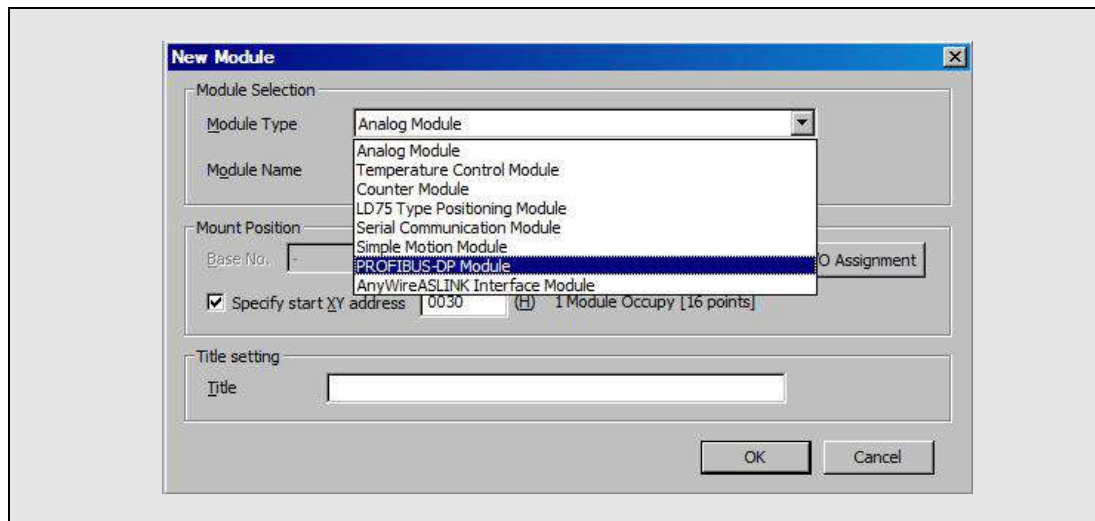

Fig. 5-8: Selection of an intelligent function module

Select **PROFIBUS-DP Module**.

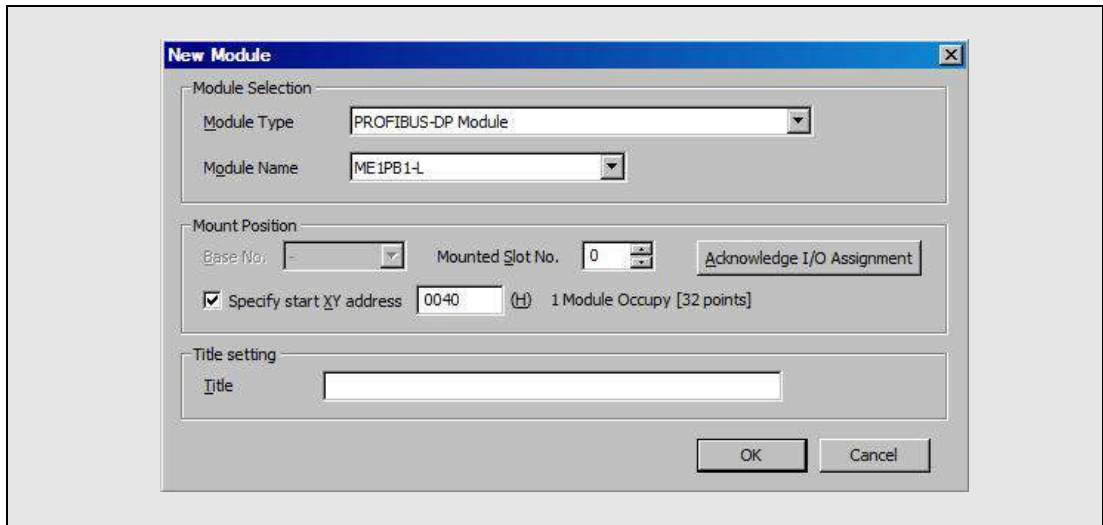

Fig. 5-9: Selection of the PROFIBUS DP master module

Enter the slot No. where the module is mounted (**Mounted Slot No.**) and the start I/O number. As **Title** you can, for instance, enter an individual name for the module. This name is then displayed in the Project Navigation window.

Afterwards click on **OK**.

The information entered on the **New Module** screen can be checked in the PLC parameters.

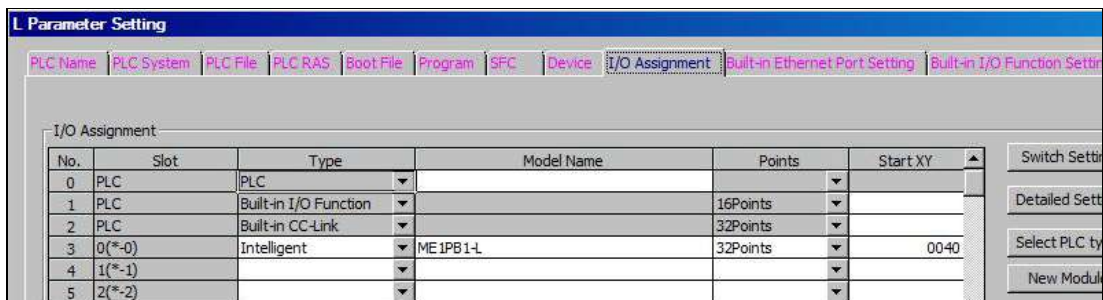

Fig. 5-10: Display of the I/O assignment in the PLC parameters

5.6.2 Parameter setting

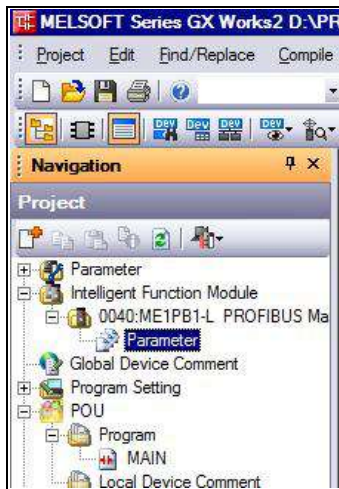

Fig. 5-11: Double-click on **Parameter**.

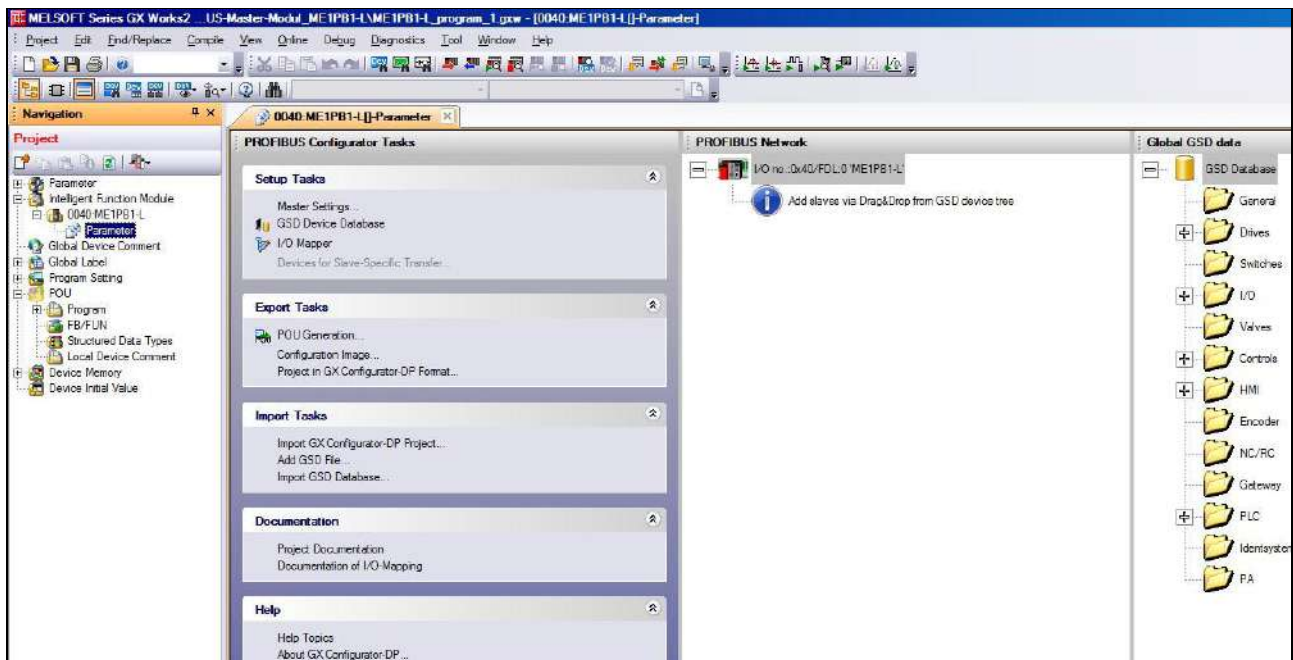

Fig. 5-12: Dialog window for parameter setting

The parameter setting for the PROFIBUS DP master module is the same as with GX Configurator DP. For more information, please refer to chapter 6 and the user’s manual of GX Configurator DP.

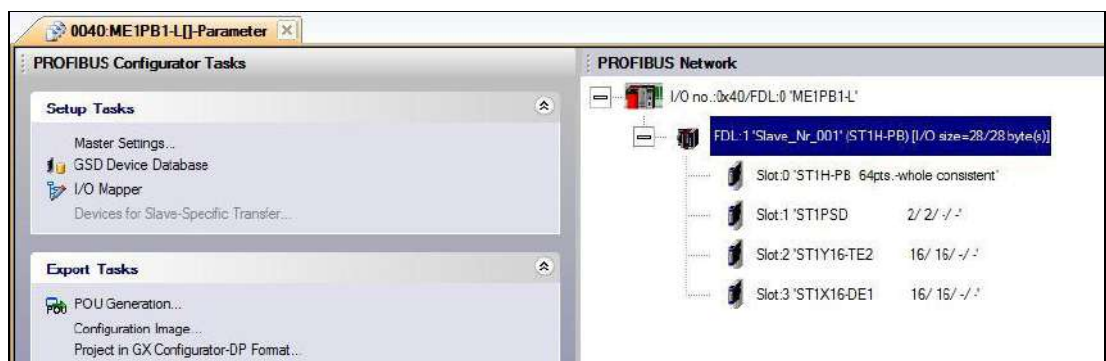

Fig. 5-13: Example for set parameters

5.6.3 Writing the intelligent function module settings to the PLC

When writing the settings for the intelligent function module to the PLC, make sure that the "Intelligent Function Module Parameter" are tagged in the **Online Data Operation** dialog box.

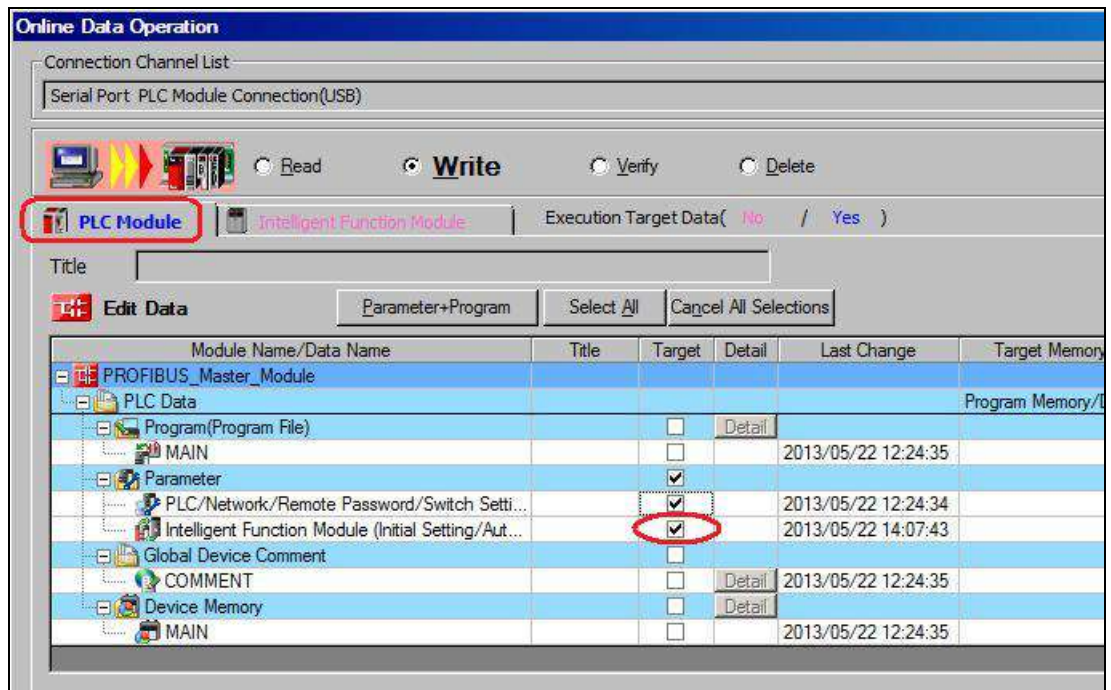

Fig. 5-14: Selection of intelligent function module parameters on the tab "PLC Module"

On the tab "Intelligent Function Module", select the ME1PB1-L.

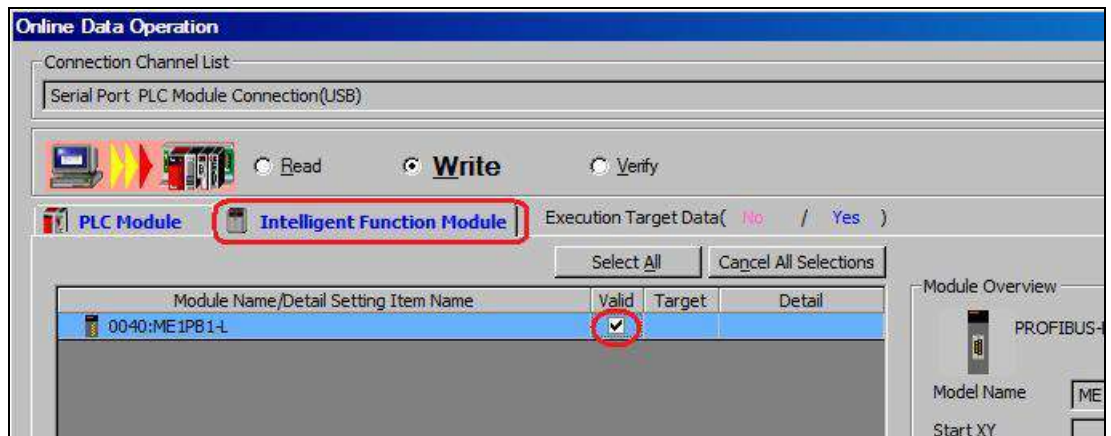

Fig. 5-15: Selection of the PROFIBUS DP master module

6 Parameter Setting

This chapter describes the procedure for setting ME1PB1-L parameters and details of the parameters. In this chapter, parameter settings when programs are created using GX Works2 are described.

6.1 Parameter Setting Procedure

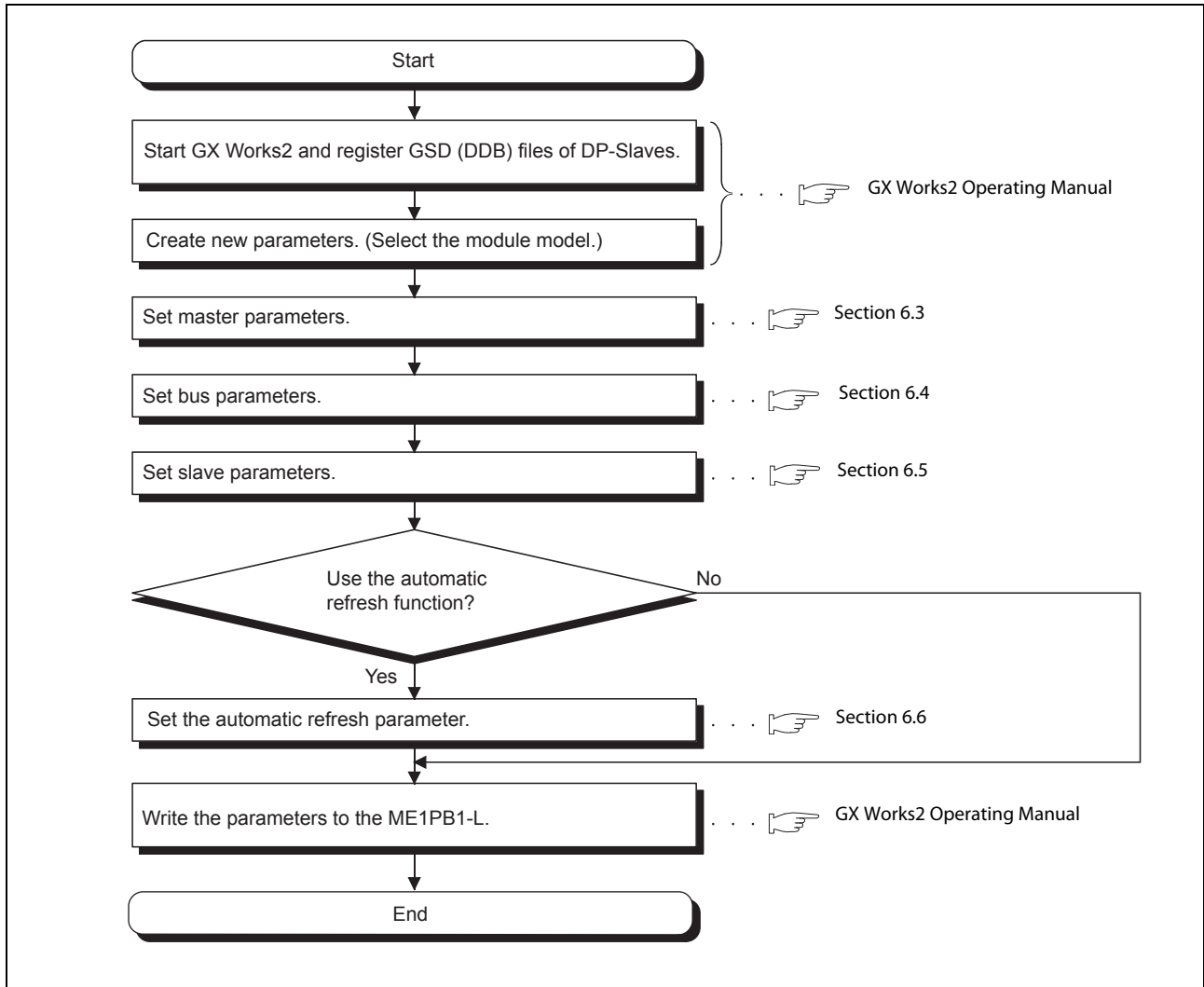

Fig. 6-1: Parameter setting procedure for a ME1PB1-L

6.2 Operation Mode Setting

This section describes ME1PB1-L operation modes and the procedure for setting the operation mode.

The operation mode of the ME1PB1-L can be changed using Operation mode change request area (Un\G2255).

NOTE

When parameters are written to the ME1PB1-L using GX Works2, the operation mode will be changed as follows:

- During writing: Parameter setting mode (mode 1)
- After writing: Communication mode (mode 3)

6.2.1 Types of operation modes

Operation mode	Description
Parameter setting mode (mode 1)	Parameters set with the intelligent function utility are written to the ME1PB1-L. When an operation mode has not been written to the flash ROM, the ME1PB1-L starts in this mode.
Self-diagnostic mode (mode 2)	A test is performed on the ME1PB1-L alone. (Refer to section 5.4)
Communication mode (mode 3)	I/O data is exchanged with DP-Slaves.
Flash ROM initialization mode	The ME1PB1-L is defaulted. (Refer to section 9.5)

Tab. 6-1: Operation modes of the ME1PB1-L

6.2.2 Operation mode change

- Write a value for a desired operation mode into the Operation mode change request area (Un\G2255). (Refer to section 3.6.3)
- Turn ON the Operation mode change request signal (Y(n+1)1).
- The Operation mode change completed signal (X(n+1)1) turns ON when the operation mode is changed, and the result of the change is stored in the Operation mode change result area (Un\G2256).
- Make sure that A300H (Normally completed) is stored in the Operation mode change result area (Un\G2256), and turn OFF the Operation mode change request signal (Y(n+1)1).
- Turning OFF the Operation mode change request signal (Y(n+1)1) turns OFF the Operation mode change completed signal (X(n+1)1).

NOTE

For a program example for changing the operation mode, refer to section .

6.2.3 Error codes for the operation mode change failure

If the operation mode change is unsuccessfully completed, an error code is stored in the Operation mode change result area (Un\G2256) on the ME1PB1-L.

For error codes, refer to section 9.4.2.

6.2.4 Precautions when changing the operation mode

When the operation mode change is attempted during I/O data exchange

When the operation mode change is attempted during I/O data exchange, the ME1PB1-L stops I/O data exchange before changing the operation mode.

The Data exchange start completed signal (Xn0) turns OFF.

Status in which the operation mode change is not executable

The operation mode change is not allowed while the ME1PB1-L is executing the following processing.

Change the operation mode after the processing is completed.

If the operation mode change is attempted during execution of the following processing, E302H is stored in the Operation mode change result area (Un\G2256):

- Acquisition of extended diagnostic information
- Global control function
- Acyclic communication
- Alarm acquisition
- Time control function

6.3 Master Parameters

Set the ME1PB1-L's transmission speed, FDL address and other parameters.

6.3.1 Start procedure

Right-click the ME1PB1-L icon in the "PROFIBUS Network" window → **Master Settings**

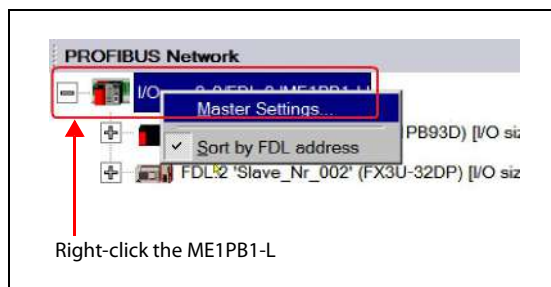

Fig. 6-2: "Master Settings" screen start procedure

6.3.2 Setting items

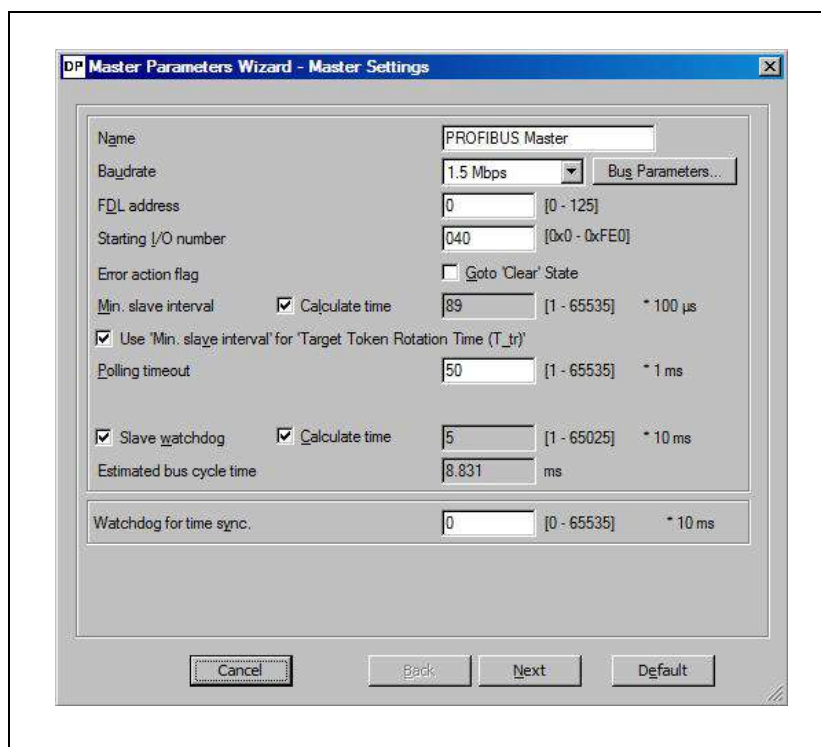

Fig. 6-3: "Master Settings" screen

Item	Description
Name	Set the name of the ME1PB1-L. Setting range: up to 16 alphanumeric characters
Baud rate	Set the transmission speed of the PROFIBUS DP. Setting range: 9.6 kbps to 12 Mbps (Default: 1.5 Mbps)
Bus Parameters button	Set bus parameters. (Refer to section 6.4)

Tab. 6-2: Master parameter setting items (1)

Item	Description
FDL address	Set the FDL address (station number). Setting range: 0 to 125 (Default: 0)
Starting I/O number	Shows the start I/O number of the ME1PB1-L in three digits. Display range: 000H to FE0H
Error action flag	Check this checkbox when sending a clear request to all DP-Slaves from the DP-Master. When a communication error occurs even in one DP-Slave, the clear request is sent to all DP-Slaves (Default: not selected). <ul style="list-style-type: none"> • Not checked: The clear request is not sent to all DP-Slaves. • Checked: The clear request is sent to all DP-Slaves.
Min. slave interval	Set the minimum required time from the slave polling cycle to the next one. This set value is enabled on all connected DP-Slaves. Set a value for the DP-Slave that needs the longest time. Setting range: 1 to 65535 (Unit: $\times 100 \mu\text{s}$, Default: $80 \times 100 \mu\text{s}$)
	Calculate time
Use 'Min. slave interval' for 'Target Token Rotation Time (T_tr)'	Select this checkbox to automatically set the "Min. slave interval" value for "Target Rot. Time (T_tr)" of the bus parameter. Clear the checkbox when multiple DP-Masters are on a PROFIBUS DP network. The sum of "Min. slave interval" values of all DP-Masters is set to "T_tr".
Polling timeout	Set the maximum time required for a requester to receive the response in communication between DP-Masters. Setting range: 1 to 65535 (Unit: $\times 1 \text{ ms}$, Default: $50 \times 1 \text{ ms}$)
Slave watchdog	Select this checkbox to batch-set watchdog timer values for all DP-Slaves. Setting range: 1 to 65025 (Unit: $\times 10 \text{ ms}$, Default: $5 \times 10 \text{ ms}$)
	Calculate time
Estimated bus cycle time	Displays the estimated minimum interval of the bus cycle time. When communications are performed with another DP-Master module or acyclic communications are performed, the bus cycle time will be longer than the displayed value. (Refer to section 3.7) When setting "Min. slave interval" and "Slave watchdog" using the displayed value, set sufficient time, considering the time that will be taken for communications with another DP-Master module or acyclic communications.
Watchdog for time sync.	Set the time during which the transmission interval of the clock data sent from the time master is monitored. Setting range: 0 to 65535 (Unit: $\times 10 \text{ ms}$, Default: $0 \times 10 \text{ ms}$)

Tab. 6-2: Master parameter setting items (2)

NOTES

When "Error action flag" is checked, outputs of all DP-Slaves are cleared when a communication error occurs even in one DP-Slave.

To restart output, perform either of the following operations.

- Turn OFF the Data exchange start request signal (Yn0) and then turn it ON.
- Reset the LCP.

When using the PROFIBUS DPV1 or PROFIBUS DPV2 function, set a "Min. slave interval" value greater than the bus cycle time calculated from Pt, Tsd and Lr. (Refer to section 3.7)

If the "Min. slave interval" is less than the value calculated from Pt, Tsd and Lr, the processing of the PROFIBUS DPV1 or PROFIBUS DPV2 function may take time.

6.4 Bus Parameters

Set the PROFIBUS DP parameters. Normally, the bus parameters are used as default values.

When changing some of the bus parameters, make sure of the PROFIBUS DP standard in advance.

6.4.1 Start procedure

Click the **Bus Parameters** button in the "Master Settings" window.

6.4.2 Setting items

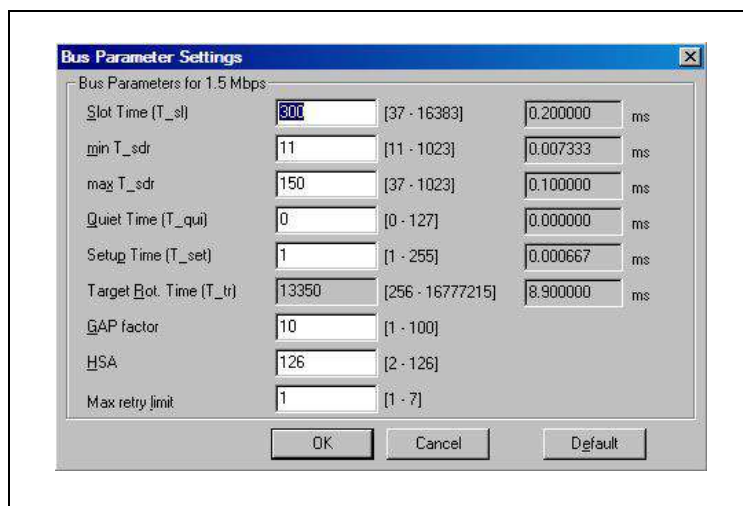

Fig. 6-4: "Bus Parameter Settings" window

Item	Description
Slot Time (T_sl)	Set the slot time (maximum time for waiting for a response). If this set time is exceeded, an error will be detected. Setting range: 37 to 16383 (Unit: $\times T_{Bit}$, Default: Depends on the transmission speed)
min T_sdr	Set the minimum response time of responders. Setting range: 11 to 1023 (Unit: $\times T_{Bit}$, Default: $11 \times T_{Bit}$)
max T_sdr	Set the maximum response time of responders. Setting range: 37 to 1023 (Unit: $\times T_{Bit}$, Default: Depends on the transmission speed)
Quiet Time (T_qui)	Set the repeater switching time (the time required for switching the transmission direction of the repeater). Set 0 when the network does not contain a repeater. Setting range: 0 to 127 (Unit: $\times T_{Bit}$, Default: Depends on the transmission speed)
Setup Time (T_set)	Set the setup time. Setting range: 1 to 255 (Unit: $\times T_{Bit}$, Default: Depends on the transmission speed)
Target Rot. Time (T_tr)	Set the target token rotation time. Setting range: 256 to 16777215 (Unit: $\times T_{Bit}$, Default: $50000 \times T_{Bit}$)
GAP factor	Set a constant for controlling the GAP update time (T_gud). Setting range: 1 to 100 (Default: 10)
HSA	Set the highest FDL address of DP-Slaves that exist on the network. Setting range: 2 to 126 (Default: 126)
Max retry limit	Set the maximum number of retries for individual data transmission. Setting range: 1 to 7 (Default: Depends on the transmission speed)

Tab. 6-3: Bus parameter setting items

NOTE

[T_{Bit}] (Bit Time) is a unit that expresses the time required for 1-bit data transmission as "1".

The actual processing time differs as shown below depending on the transmission speed.

- In the case of 1.5 Mbps:
 $1 [T_{\text{Bit}}] = 1 / (1.5 \times 10^6) = 0.667 \times 10^{-6} \text{ s}$
- In the case of 12 Mbps:
 $1 [T_{\text{Bit}}] = 1 / (12 \times 10^6) = 0.083 \times 10^{-6} \text{ s}$

T_{Bit} is converted into ms automatically by the intelligent function utility. The results of the conversion (ms) are displayed on the right side of the screen.

6.4.3 Precautions for bus parameter setting

For each set value of the max T_{sdr}, Quiet Time (T_{qui}) and Setup Time (T_{set}), set the maximum value among those of the stations connected to PROFIBUS DP (including the DP-Master).

The default value of the ME1PB1-L varies depending on the transmission speed.

Item	Default values of ME1PB1-L					
	187.5 kbps or less	500 kbps	1.5 Mbps	3 Mbps	6 Mbps	12 Mbps
max T _{sdr}	60	100	150	250	450	800
Quiet Time (T _{qui})	0	0	0	3	6	9
Setup Time (T _{set})	1	1	1	4	8	16

Tab. 6-4: Default values of max T_{sdr}, Quiet Time (T_{qui}) and Setup Time (T_{set})

6.5 Slave Parameters

Set parameters for each DP-Slave.

6.5.1 Start procedure

Right-click the DP-Slave icon in the "PROFIBUS Network" window → **Slave Settings**.

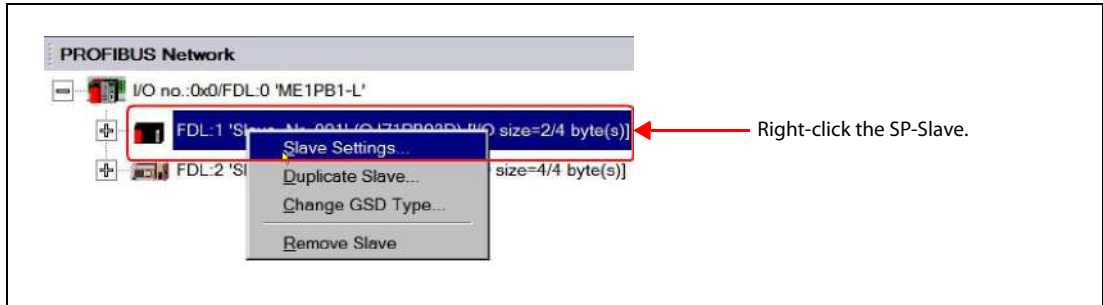

Fig. 6-5: "Slave Settings" window start procedure

6.5.2 Setting items

- "Slave Settings" window

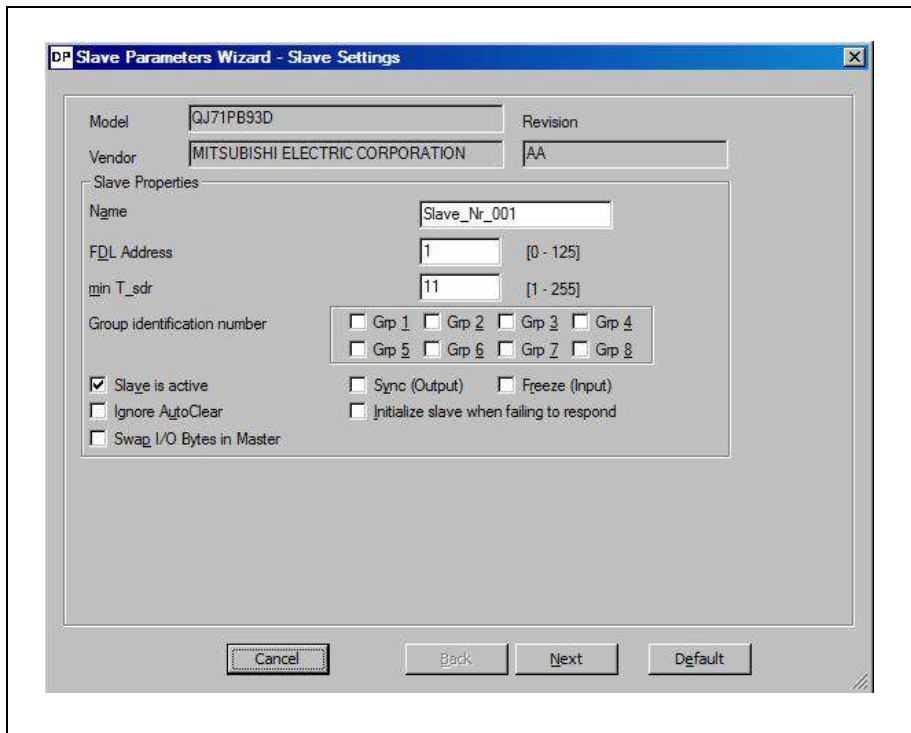

Fig. 6-6: "Slave Settings" window

Item	Description
Model	Displays the model name of the DP-Slave.
Vendor	Displays the vendor of the DP-Slave.
Revision	Displays the versions of the GSD(DDB) file and the device.
Name	Set the name of the DP-Slave. Setting range: up to 16 alphanumeric characters
FDL Address	Set the FDL address (station number). Setting range: 0 to 125
min T_sdr	Set the minimum response time required for a DP-Slave to send a response frame to the ME1PB1-L. Normally, use the default value. Setting range: 1 to 255 (Unit: $\times T_{\text{Bit}}$, Default: $11 \times T_{\text{Bit}}$)
Group identification number	Set the group No. (Grp 1 to Grp 8) of the DP-Slave. Multiple groups Nos. can also be set. The set group numbers are used for the global control function (SYNC, UNSYNC, FREEZE, UNFREEZE). <ul style="list-style-type: none"> • Not checked: Not belonging to the group No. • Checked: Belonging to the group No.
Slave is active	Uncheck the checkbox when the DP-Slave is to be set as a reserved station (Default: selected). <ul style="list-style-type: none"> • Not checked: Set as a reserved station. • Checked: Set as a station performing I/O data exchange.
Sync (Output)	Check the checkbox to check if the DP-Slave supports the Sync function or not in communication for initialization. When the DP-Slave does not support the Sync function, diagnostic information is stored in the Diagnostic information area (for mode 3) (Un\G23072 to Un\G23321) of the ME1PB1-L. This item can be set when the DP-Slave supports this function (Default: not selected). <ul style="list-style-type: none"> • Not checked: No function check • Checked: Function check performed
Freeze (Input)	Check the checkbox to check if the DP-Slave supports the Freeze function or not in communication for initialization. When the DP-Slave does not support the Freeze function, the diagnostic information is stored in the Diagnostic information area (for mode 3) (Un\G23072 to Un\G23321) of the ME1PB1-L. This item can be set when the DP-Slave supports this function (Default: not selected). <ul style="list-style-type: none"> • Not checked: No function check • Checked: Function check performed
Ignore AutoClear	Select this checkbox to disable clear request transmission if a communications failure is detected on the DP-Slave, even though the master parameter, "Error action flag" is enabled. This setting is available when the "Error action flag" setting in the master parameters is enabled (Default: not selected). <ul style="list-style-type: none"> • Not checked: Enables "Error action flag" setting. • Checked: Disables "Error action flag" setting.
Initialize slave when failing to respond	Select this checkbox so that the DP-Master resends parameters to DP-Slaves when the DP-Master is restored from the status of a communication error (Default: not selected). <ul style="list-style-type: none"> • Not selected: Not resend parameters to DP-Slaves. • Selected: Resends parameters to DP-Slaves.
Swap I/O Bytes in Master	Select this checkbox to swap the I/O data of the DP-Slave on the ME1PB1-L buffer memory (Default: not selected). <ul style="list-style-type: none"> • Not selected: No swapping • Selected: Enables data swapping

Tab. 6-5: Slave parameter setting items

6.5.3 DP V1/V2 Slave Parameters screen

The following window opens when the DP-Slave supports the PROFIBUS DPV1/V2 function.

Start procedure:

Click the **Next** button in the "Slave Settings" window until the "DP V1/V2 Slave Parameters" window will open.

Setting items

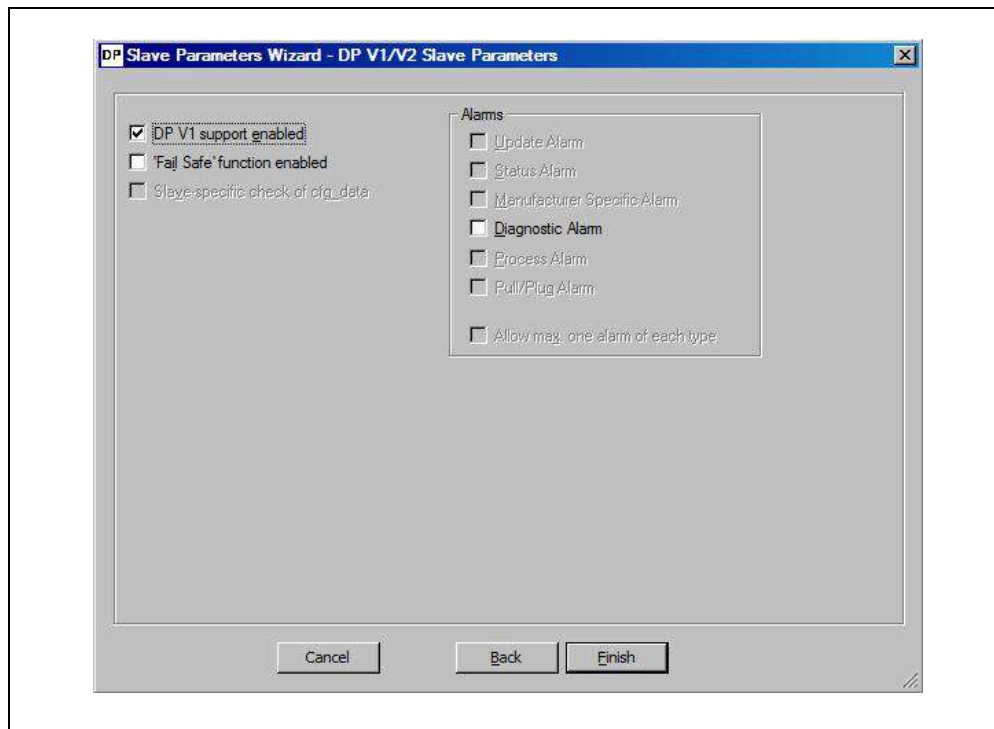

Fig. 6-7: "DP V1/V2 Slave Parameters" screen

Item	Description
DP V1 Support enable	Check this checkbox to use the PROFIBUS DPV1 functions. This setting is available when the DP-Slave supports the PROFIBUS DPV1 functions. <ul style="list-style-type: none"> • Not checked: Not use the PROFIBUS DPV1 functions • Checked: Use the PROFIBUS DPV1 functions
'Fail Safe' function enable ①②	Check this checkbox to place the DP-Slave into the 'Fail Safe' status when the DP-Master sends a clear request. For the 'Fail Safe' setting, refer to the manual for the DP-Slave. <ul style="list-style-type: none"> • Not checked: Not placed into 'Fail Safe' status • Checked: Placed into 'Fail Safe' status
Slave-specific check of cfg_data ①	Check this checkbox when the parameter check method for the DP-Slave is different from that of the PROFIBUS standard. For the parameter check method, refer to the manual for the DP-Slave. <ul style="list-style-type: none"> • Not checked: Checks parameters based on the PROFIBUS standard • Checked: Checks parameters by the DP-Slave-specific method.
Update Alarm ①②	Check this checkbox to enable transmission of the Update Alarm. <ul style="list-style-type: none"> • Not checked: Disables transmission of the Update Alarm • Checked: Enables transmission of the Update Alarm

Tab. 6-6: DP V1/V2 slave parameters setting items (1)

Item	Description
Status Alarm ①②	Check this checkbox to enable transmission of the Status Alarm. <ul style="list-style-type: none"> • Not checked: Disables transmission of the Status Alarm • Checked: Enables transmission of the Status Alarm
Manufacturer Specific Alarm ①②	Check this checkbox to enable transmission of the Manufacturer Specific Alarm. <ul style="list-style-type: none"> • Not checked: Disables transmission of the Manufacturer Specific Alarm • Checked: Enables transmission of the Manufacturer Specific Alarm
Diagnostic Alarm ①②	Check this checkbox to enable transmission of the Diagnostic Alarm. <ul style="list-style-type: none"> • Not checked: Disables transmission of the Diagnostic Alarm • Checked: Enables transmission of the Diagnostic Alarm
Process Alarm ①②	Check this checkbox to enable transmission of the Process Alarm. <ul style="list-style-type: none"> • Not checked: Disables transmission of the Process Alarm • Checked: Enables transmission of the Process Alarm
Pull/Plug Alarm ①②	Check this checkbox to enable transmission of the Pull/Plug Alarm. <ul style="list-style-type: none"> • Not checked: Disables transmission of the Pull/Plug Alarm • Checked: Enables transmission of the Pull/Plug Alarm
Allow max. one alarm of each type ①②	Check this checkbox to acquire alarms one by one for each type when the DP-Slave detects multiple types of alarms. <ul style="list-style-type: none"> • Not checked: Acquires alarms in order of occurrence. (Max. 8 alarms) • Checked: Acquires generated alarms one by one for each type (Max. 6 alarms)

Tab. 6-6: DP V1/V2 slave parameters setting items (2)

- ① This setting is available when the DP-Slave supports this function.
 ② This item is fixed to be selected depending on the DP-Slave status.

6.6 Automatic Refresh Parameters

Set the automatic refresh parameters by which data in the ME1PB1-L buffer memory are automatically transferred to LCPU devices.

6.6.1 Automatic refresh parameter setup procedure

The following describes the automatic refresh parameter setup procedure.

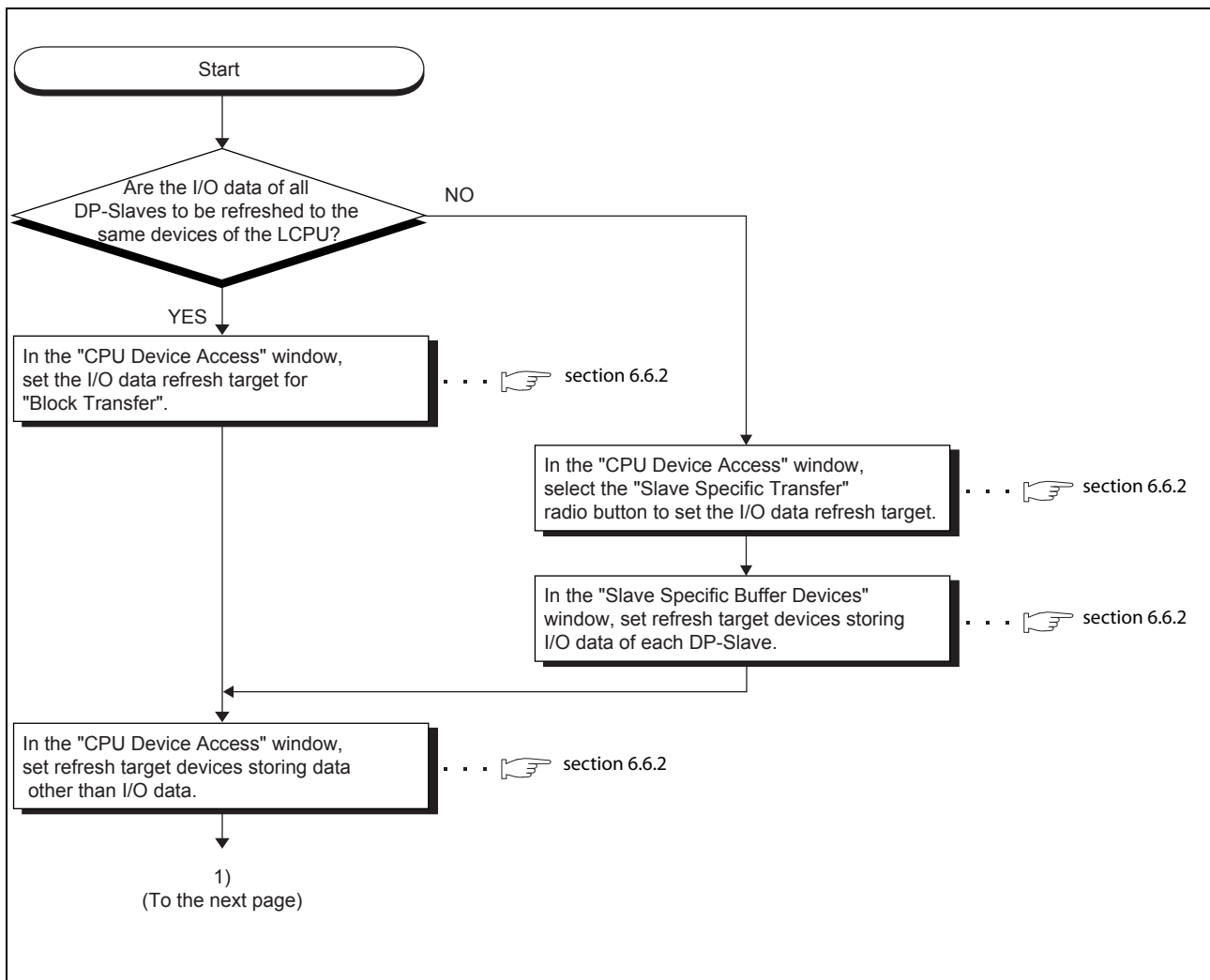

Fig. 6-8: Automatic refresh parameter setting procedure (1)

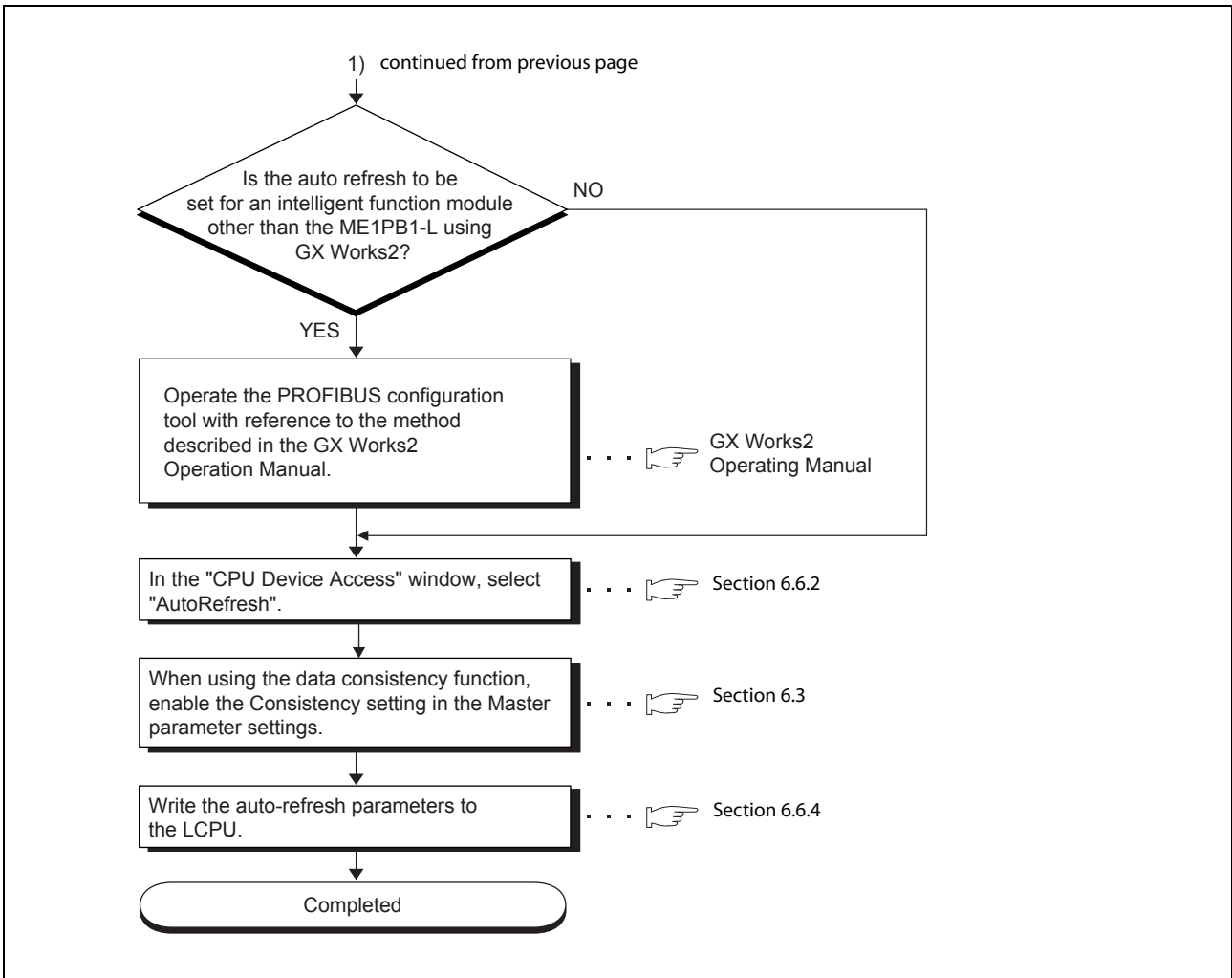

Fig. 6-8: Automatic refresh parameter setting procedure (2)

6.6.2 Automatic refresh settings

CPU Device Access window

Set the automatic refresh setting.

Start procedure

Click the **Next** button in the "Master Settings" window.

Setting items

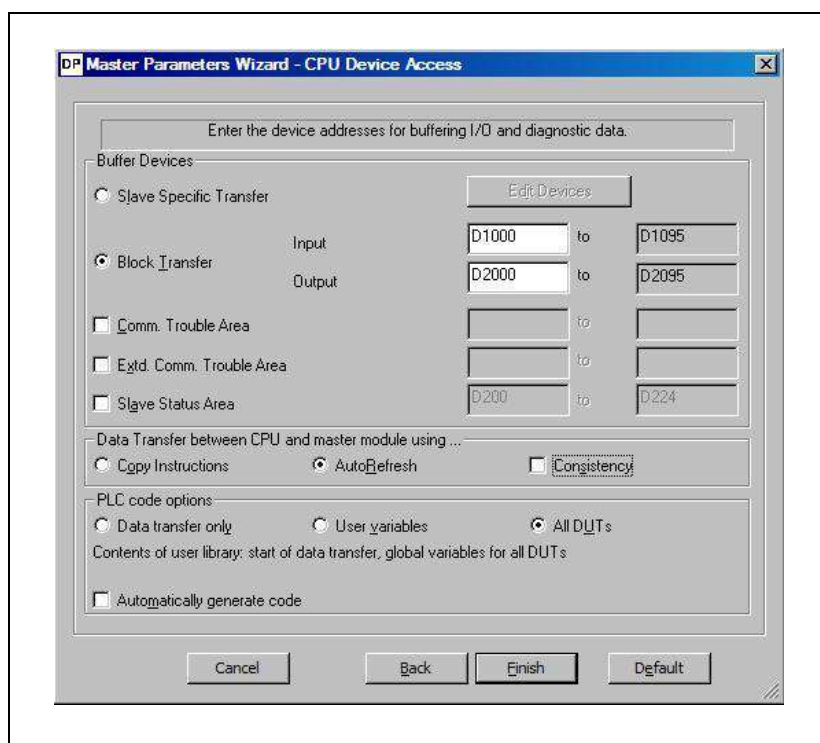

Fig. 6-9: "CPU Device Access" window

Item	Description
Buffer Devices	Set the LCPUs start device used for communications between the ME1PB1-L and the LCPU.
Slave Specific Transfer	Select this radio button to set automatic refresh for each DP-Slave. After setting this item, set the target device in the "Slave Specific Buffer Devices" window. (Refer to section 6.6.3) Click the Edit Devices button to display the "Slave Specific Buffer Devices" window. Selecting the "Block Transfer" radio button will set the same automatic refresh device for all DP-Slaves. This allows reduction in the number of settings. (Refer to section 6.6.5)
Edit Devices button	Displays the "Save Specific Buffer Devices" window. (Refer to page 6-16)
Block Transfer	Select this radio button to set the same automatic refresh device for all DP-Slaves. Devices are set in the following "Input" or "Output". <ul style="list-style-type: none"> Input: Device used for the communication of input data is set. (Default: D1000) For a bit device, setting must be made in units of 16 points. To use I/O Mapping, set a word device. Output: Device used for the communication of output data is set. (Default: D2000) For a bit device, setting must be made in units of 16 points. To use I/O Mapping, set a word device. Automatic refresh target for each module can be checked in "Documentation of I/O-Mapping". For details on "Documentation of I/O-Mapping", refer to the GX Works2 Operating Manual.
Comm. Trouble Area	Set the automatic refresh target device of the Diagnostic information area (for mode 3) (Un\G23072 to Un\G23321).
Extd. Comm. Trouble Area	Set the automatic refresh target device of Extended diagnostic information area (for mode 3) (Un\G23328 to Un\G23454).
Slave Status Area	Set the automatic refresh target devices of the following areas. <ul style="list-style-type: none"> Slave status area (Normal communication detection) (Un\G23040 to Un\G23047) Slave status area (Reserved station setting status) (Un\G23048 to Un\G23055) Slave status area (Diagnostic information detection) (Un\G23056 to Un\G23064)
Data Transfer between CPU and master module using	Set a communications method between the DP-Master module and the LCPU.
Copy Instructions	Select this item in case of communication using the FROM/TO/MOV instruction and dedicated instruction.
AutoRefresh	Select this item in case of communication using the automatic refresh. With this item selected, automatic refresh parameters will be written to the LCPU when a project is downloaded. When automatic refresh has been set for another intelligent function module using GX Works2, specify the project in the "Project Properties" window. (Refer to GX Works2 Operating Manual) Doing so will update the automatic refresh parameters of the specified project when the project is downloaded.
Consistency	Select this checkbox to use the data consistency function during automatic refresh. (Refer to section 4.5) This item can be selected while "AutoRefresh" is enabled (Default: not selected). <ul style="list-style-type: none"> Not selected: data consistency function disabled Selected: data consistency function enabled
PLC code options	Set these items to use GX IEC Developer. (This setting is not required when the intelligent function utility is used.) For details, refer to the GX Works2 Operating Manual.
Data transfer only	
User variables	
All DUTs	

Tab. 6-7: Automatic refresh setting items

NOTE

Set "Block Transfer" for the following applications.

- To refresh I/O data of all DP-Slaves into the same kind of device
- To reduce the number of automatic refresh parameters of the ME1PB1-L, and increase the automatic refresh parameters of other intelligent function modules

6.6.3 Slave Specific Buffer Devices window

Set the devices used for the communication in units of DP-Slaves.

Operation procedure

Click the **Edit Devices** button in the "CPU Device Access" window.

Setting items

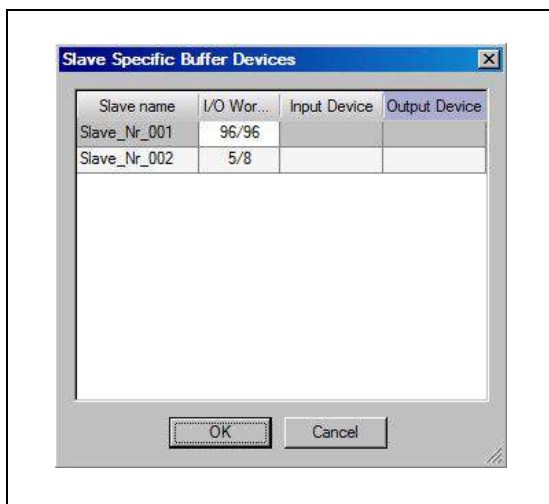

Fig. 6-10:
"Slave Specific Buffer Devices" window

Item	Description
Slave name	Displays the DP-Slave name specified in the "Name" field of the "Slave Settings" window.
I/O Word Size	Displays the I/O data size of the DP-Slave (unit: word). The display format is: Number of words of input data/number of words of output data.
Input Device	Set the start device used for input data communications. Set a value in unit of 16 points for a bit device. After the start device is entered, the device range is displayed with the start and end addresses.
Output Device	Set the start device used for output data communications. Set a value in unit of 16 points for a bit device. After the start device is entered, the device range is displayed with the start and end addresses.

Tab. 6-8: Automatic refresh setting items for each DP-Slave

6.6.4 Writing automatic refresh parameters

Write the automatic refresh parameters to the LCPU.

Reset the LCPU after writing the automatic refresh parameters.

Start procedure

- ① Select **Download to Module** in **Task Panel**.
- ② Check that the **Update Autorefresh settings** checkbox is selected in the "Select Items for Download" window.

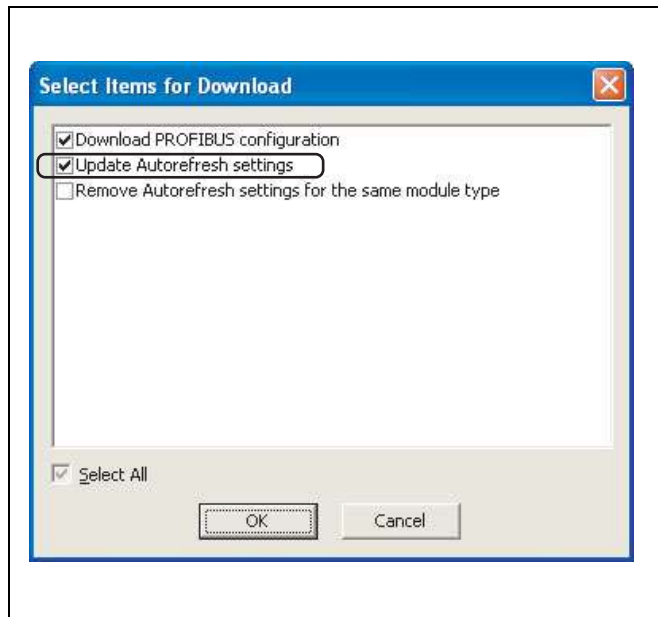

Fig. 6-11: "Select Items for Download" window

- ③ Click the **OK** button.
The automatic refresh parameters will be written to the LCPU.

6.6.5 Number of set automatic refresh parameters

Set the auto refresh parameters so that the number of parameters, including these of other intelligent function modules, does not exceed the number of parameters that can be set in the CPU module or the head module.

For the maximum number of parameters that can be set in the CPU module or the head module (maximum number of parameter settings), refer to the following.

- MELSEC-L CPU Module User's Manual (Hardware Design, Maintenance and Inspection)
- MELSEC-L CC-Link IE Field Network Head Module User's Manual

Number of automatic refresh parameter settings for the ME1PB1-L

The number of automatic refresh parameter settings for the ME1PB1-L varies depending on the automatic refreshing setting method for I/O data.

- When "Block Transfer" is used

When the automatic refresh of I/O data is set by "Block Transfer" (i.e. I/O data of all DP-Slaves are refreshed into the same kind of device), up to five automatic refresh parameters can be set per ME1PB1-L.

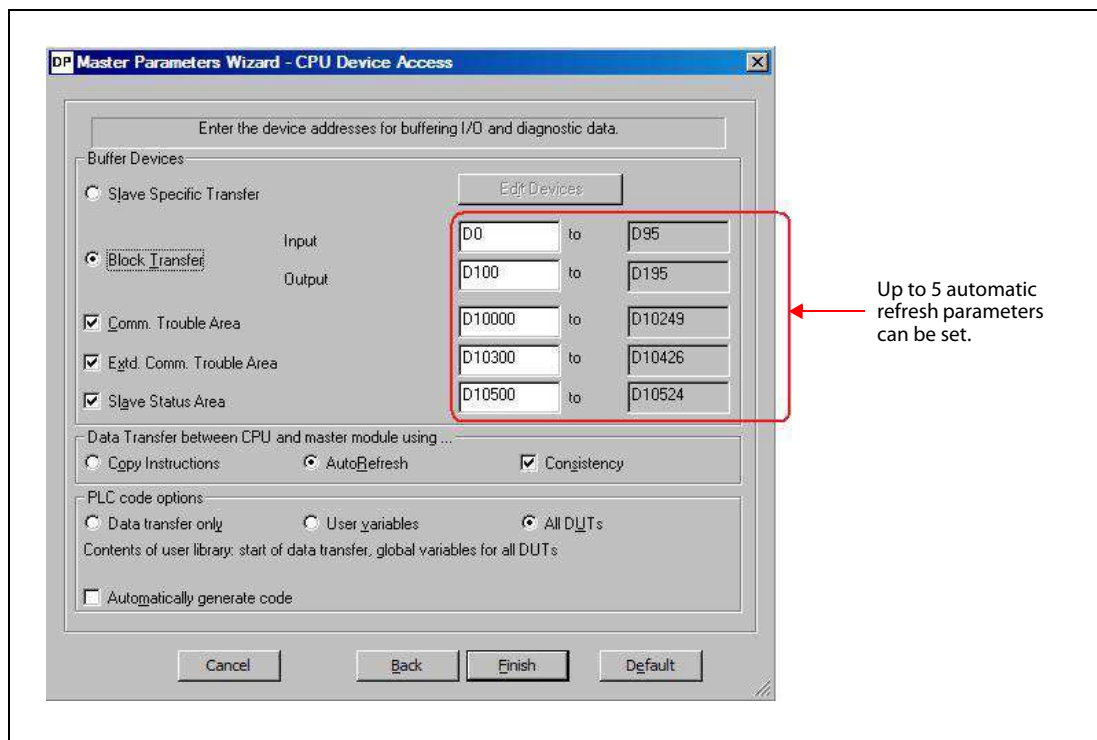

Fig. 6-12: Number of automatic refresh parameter settings (when set by "Block Transfer")

- When "Slave Specific Transfer" is used

When the automatic refresh of I/O data is set by "Slave Specific Transfer" (i.e. when changing the refresh target device on a per-DP-Slave basis), the following number of automatic refresh parameters can be set per ME1PB1-L.

$$\text{Max. number of settings} = \{(\text{Number of connected DP-Slaves}) \times 2\} + 3$$

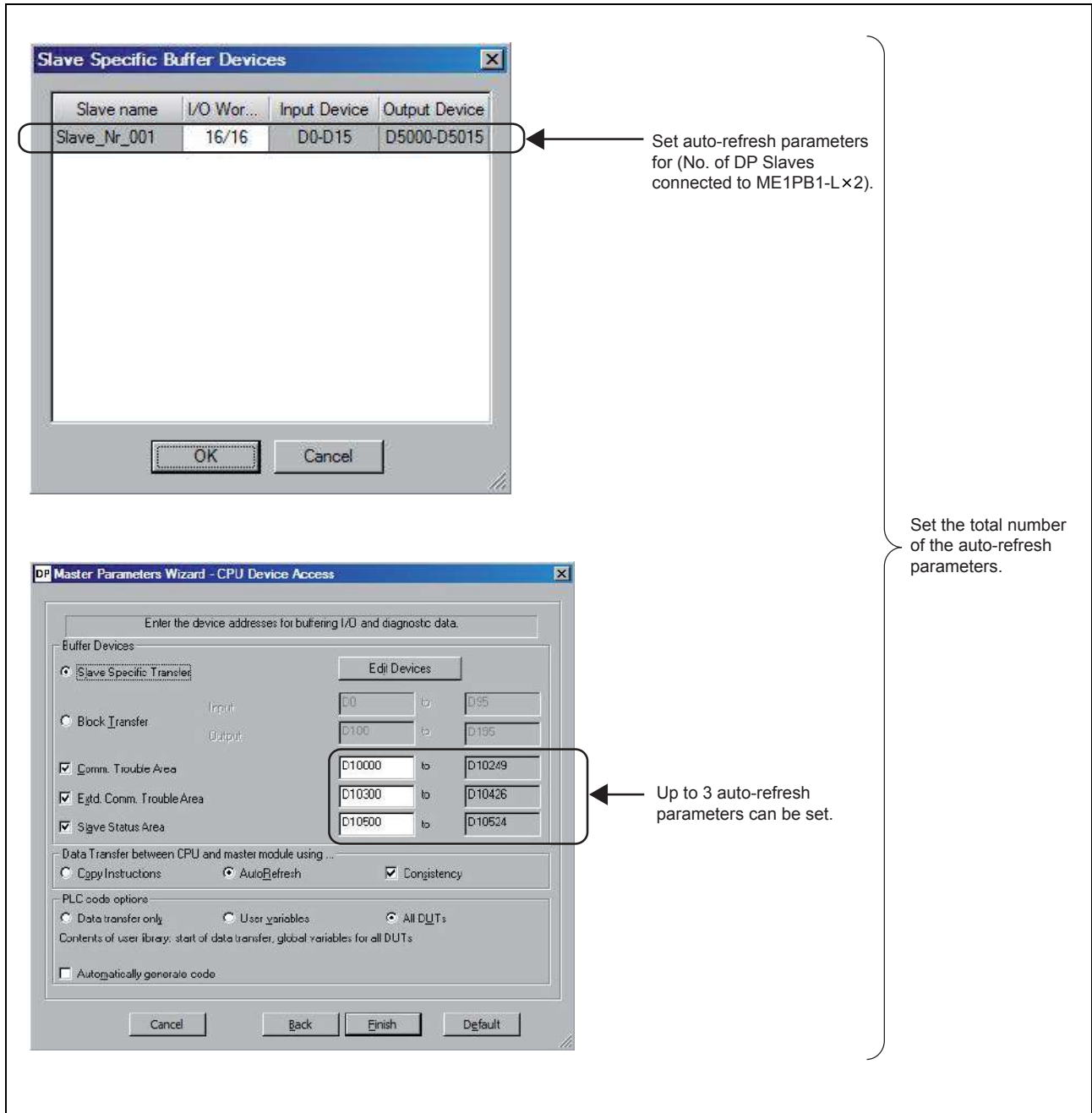

Fig. 6-13: Number of automatic refresh parameter settings (when set by "Slave Specific Transfer")

6.7 PLC Parameter Setting by GX Works2

On the I/O Assignment tab in the PLC parameters, set the output status for the case of a CPU stop error. For the setting method, refer to section 4.6.

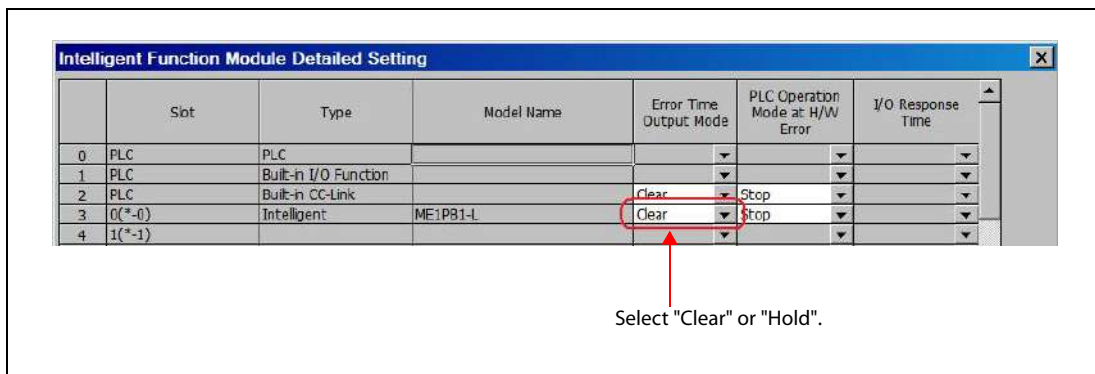

Fig. 6-14: Detailed settings for intelligent function modules

7 Programming

This chapter describes the programming for the PROFIBUS master module ME1PB1-L.

NOTE

When applying any of the program examples introduced in this chapter to the actual system, verify the applicability and confirm that no problems will occur in the system control.

The following lists the installation positions of the ME1PB1-L and corresponding program examples shown in this chapter.

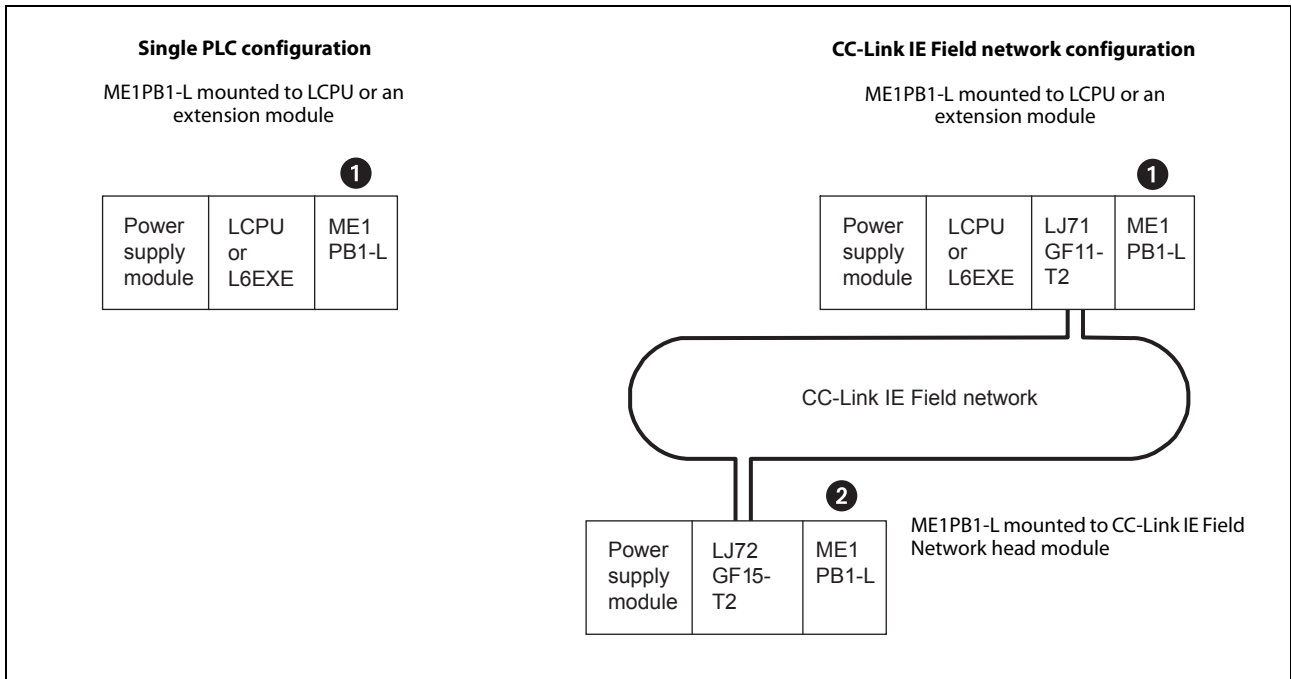

Fig. 7-1: Installation positions of the ME1PB1-L and corresponding program examples in this chapter

Installation position	Reference
①	Sections 7.1 to 7.6
②	Section 7.8

Tab. 7-1:

Installation positions of the ME1PB1-L and corresponding program examples in this chapter

7.1 I/O Data Exchange Program Examples

This section explains the examples of I/O data exchange programs. The following system configuration is used as an example for explanations in section 7.1.1.

System configuration for the examples

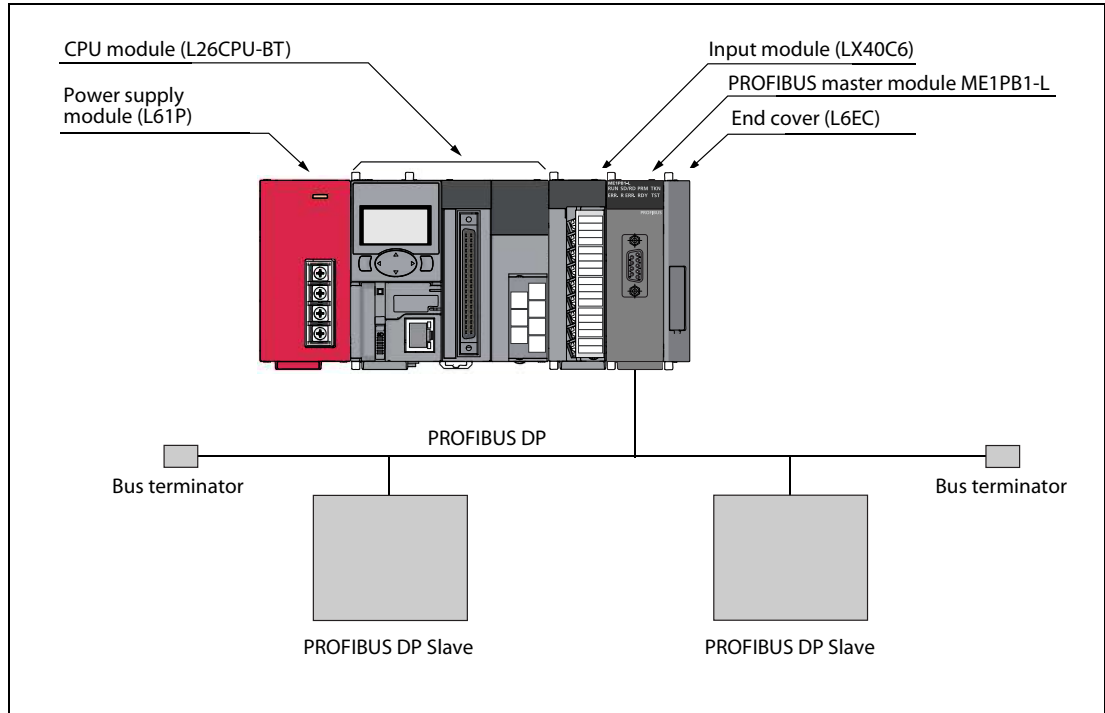

Fig. 7-2: In this example the ME1PB1-L is mounted to the CPU module together with an input module.

PLC Name	PLC System	PLC File	PLC-RAS	Boot File	Program	SFC	Device	I/O Assignment	Built-in Ethernet Port Setting
I/O Assignment									
No.	Slot	Type	Model Name			Points	Start XY		
0	PLC	PLC	L26CPU-Bt						
1	PLC	Built-in I/O Function				16Points			
2	PLC	Built-in CC-Link				32Points			
3	0(*-0)	Input	LX40C6			16Points	0030		
4	1(*-1)	Intelligent	ME1PB1-L			32Points	0040		
5	2(*-2)								
6	3(*-3)								
7	4(*-4)								

Fig. 7-3: I/O assignment in the program example

Module	Input signals	Output signals
LX40C6	X30 to X3F	—
ME1PB1-L	X40 to X5F	Y40 to Y5F

Tab. 7-2: Assignment of input and output signals

Settings

● ME1PB1-L settings

Item		Description
FDL address		FDL address 0
Transmission speed		1.5 Mbps
Operation mode		Communication mode (mode 3)
I/O data area for FDL address 1 (Buffer memory)	Input data area (for mode 3)	6144 (1800H) to 6239 (185FH)
	Output data area (for mode 3)	14336 (3800H) to 14431 (385FH)
I/O data area for FDL address 2 (Buffer memory)	Input data area (for mode 3)	6240 (1860H)
	Output data area (for mode 3)	14432 (3860H)

Tab. 7-3: Assignment of input and output signals

● DP-Slave settings

Item		Description
FDL address		FDL address 1
I/O data size	Input data size	96 words (192 bytes)
	Output data size	96 words (192 bytes)

Tab. 7-4: Settings for the DP-Slave No. 1

Item		Description
FDL address		FDL address 2
I/O data size	Input data size	1 word (2 bytes)
	Output data size	1 word (2 bytes)

Tab. 7-5: Settings for the DP-Slave No. 2

● Parameter settings on the intelligent function utility

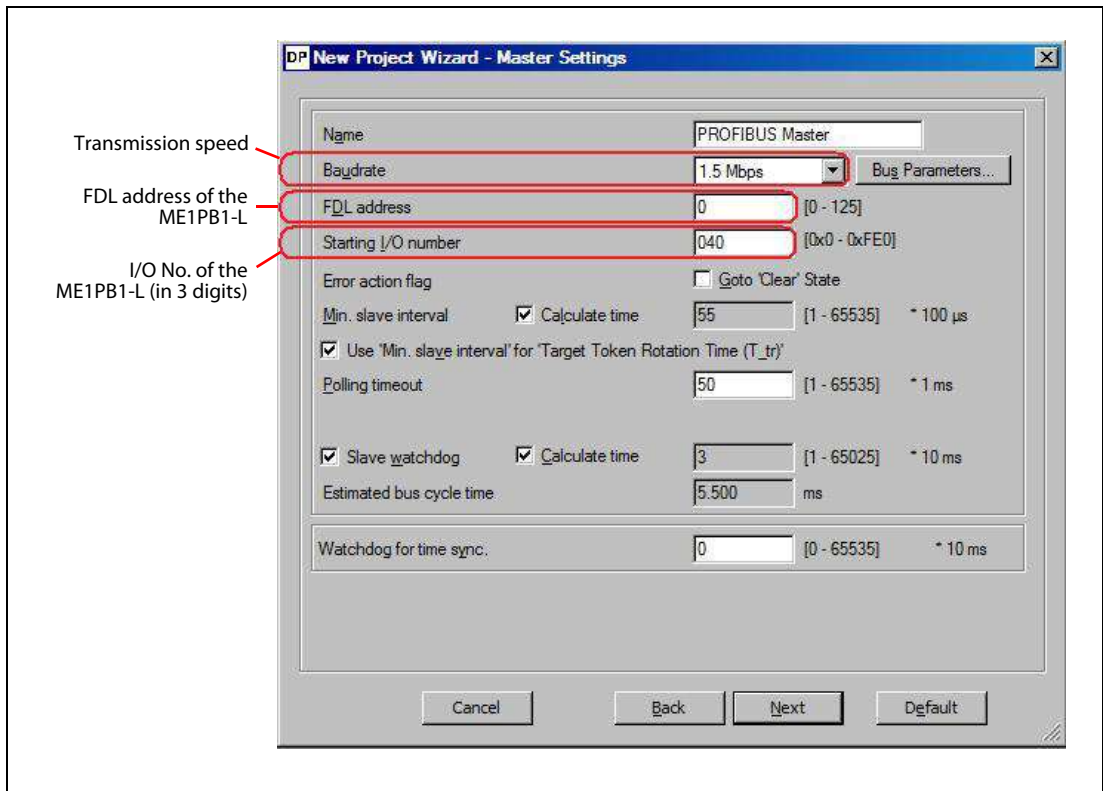

Fig. 7-4: Master parameter settings for this example

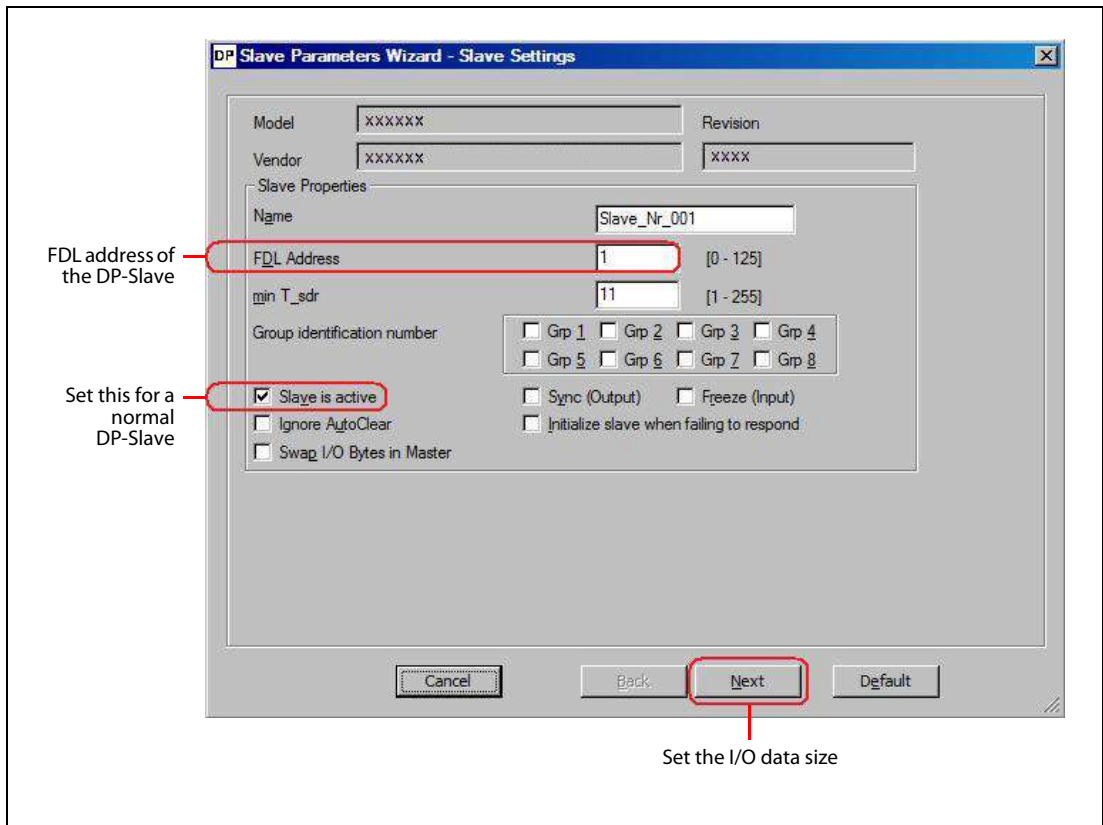

Fig. 7-5: Slave parameter settings for this example

Assignment of devices in program examples

The program examples given in the sections to 7.1.3 use the following device assignments.

- Devices occupied by the ME1PB1-L

Device (Input)	Description	Device (Output)	Description
X40	Data exchange start completed signal	Y40	Data exchange start request signal
X41	Diagnostic information detection signal	Y41	Diagnostic information detection reset request signal
X42	Diagnostic information area cleared signal	Y42	Diagnostic information area clear request signal
X4C	Data consistency requesting signal	Y4C	Data consistency start request signal
X51	Operation mode change completed signal	Y51	Operation mode change request signal
X5B	Communication READY signal	—	—
X5D	Module READY signal		
X5F	Watchdog timer error signal		

Tab. 7-6: List of devices from/to the ME1PB1-L

- Devices for the user

Device	Description	Device	Description
X30	I/O data exchange start command	SM402	ON for 1 scan only after RUN
X31	Communication error detection reset command	M0	ME1PB1-L is ready for communication
X32	Communication error area clear command	M2	For operation mode change interlock
X33	Operation mode change command	M400	Initial setting execution command
X3E	Conditions for write to output data (1st word)	—	—
X3F	Conditions for write to output data (2nd word)		

Tab. 7-7: List of devices for the user

- Devices used as automatic refresh or buffer memory read target

Device	Description	Device	Description
D0 to D95	Input data	D1000	Diagnostic information read target
D100 to D195	Output data	D1100	Read target of operation mode change result
D200 to D207	Slave status area (Normal communication detection)	—	—
D208 to D215	Slave status area (Reserved station setting status)		
D216 to D224	Slave status area (Diagnostic information detection)		

Tab. 7-8: List of devices used as automatic refresh or buffer memory read target

7.1.1 Program examples using automatic refresh

This section explains a program for the case where the ME1PB1-L communicates with DP-Slaves using automatic refresh.

Program examples in this section are based on the system configuration example shown on the previous pages.

Setting automatic refresh parameters

Enable the automatic refresh parameters and the data consistency function. The figure below shows the case that automatic refresh parameters are set by "Block Transfer".

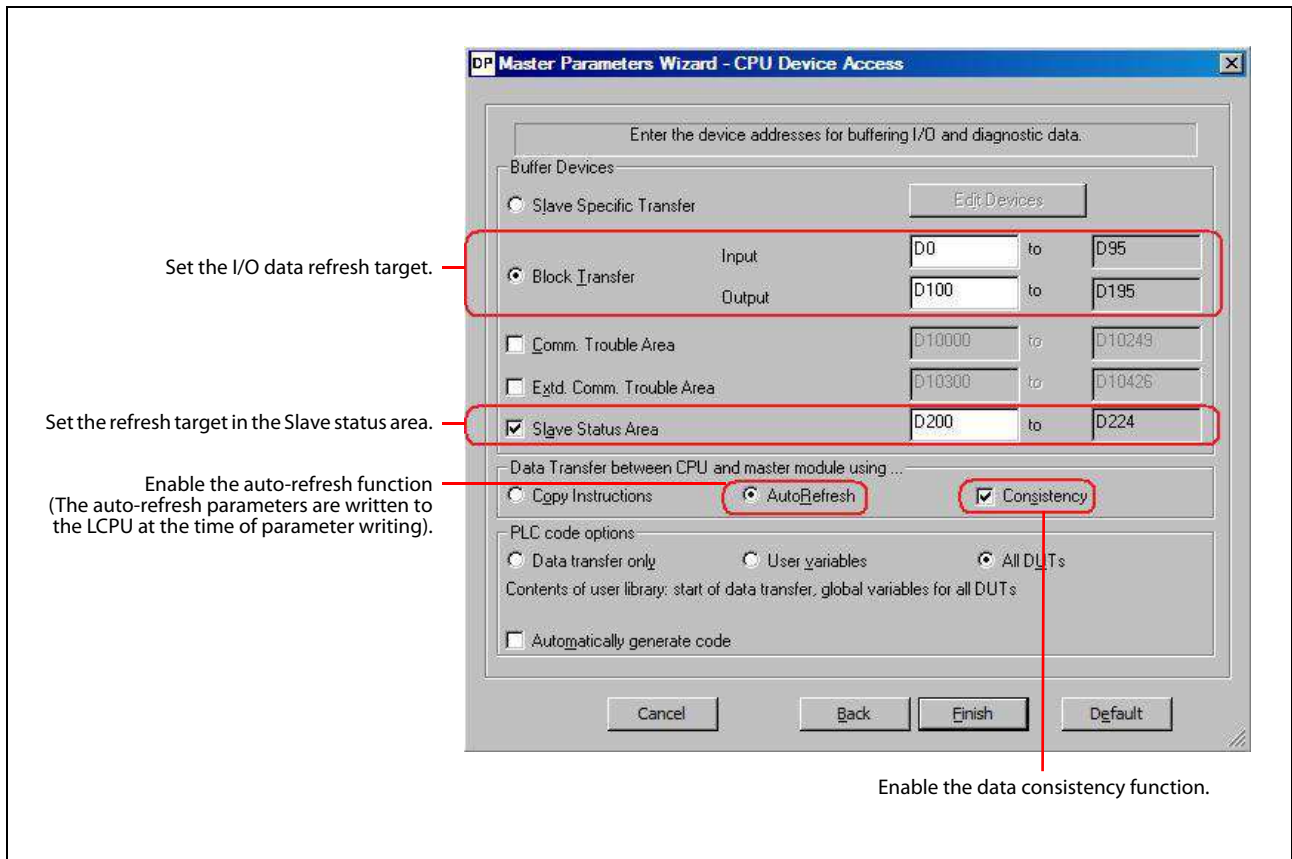

Fig. 7-6: Automatic refresh parameter setting example

Program example

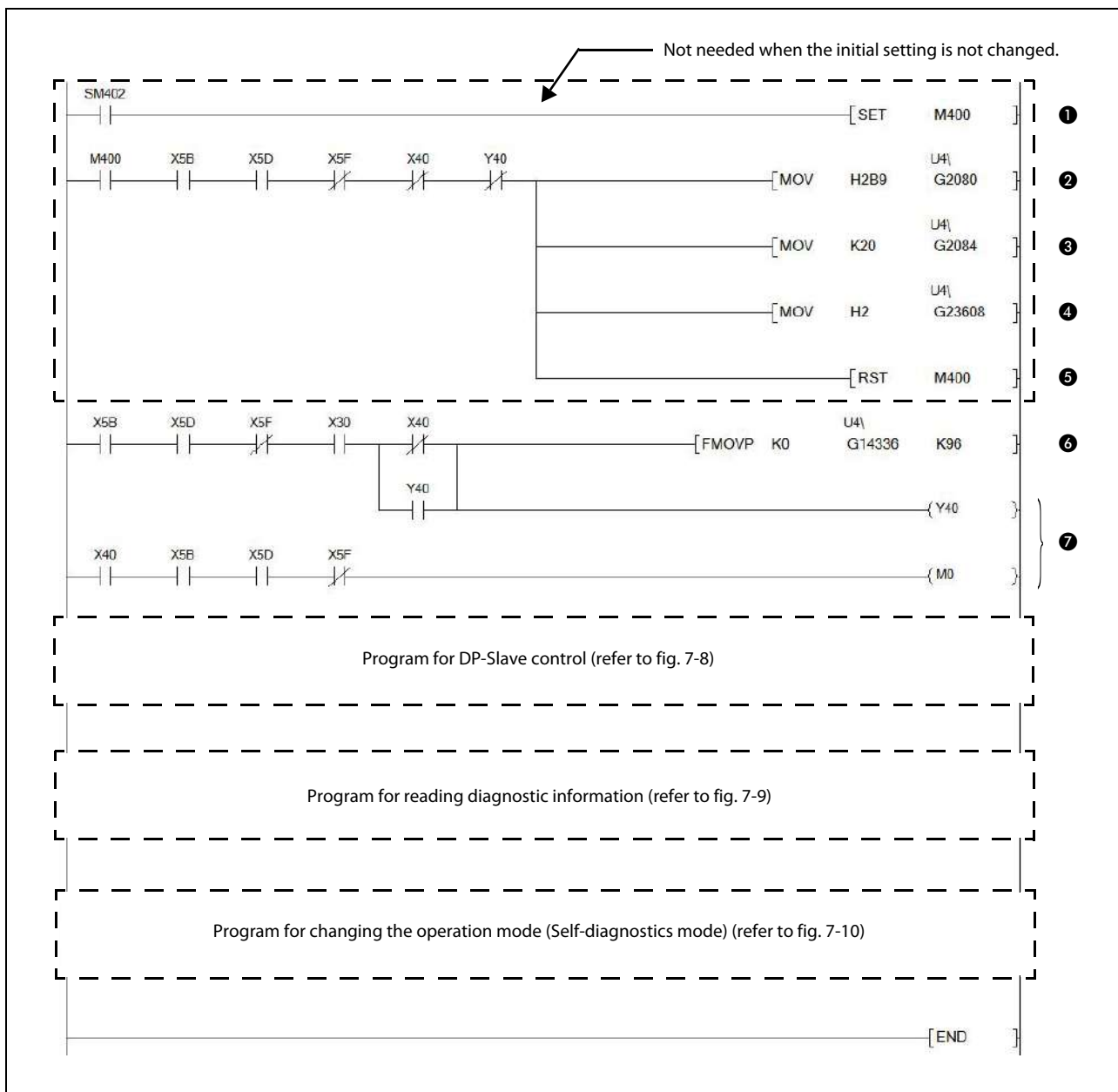

Fig. 7-7: I/O data exchange program examples (automatic refresh)

No.	Description
①	Turn ON the initial setting execution command
②	Initializes Diagnostic information invalid setting area
③	Initializes Diagnostic information non-notification time setting area
④	Specifies the 2nd temporary slave reservation
⑤	Turn OFF the initial setting execution command
⑥	Writes the initial output data value.
⑦	I/O data exchange start processing

Tab. 7-9: Description of fig. 7-7

● Program example for control of DP-Slaves

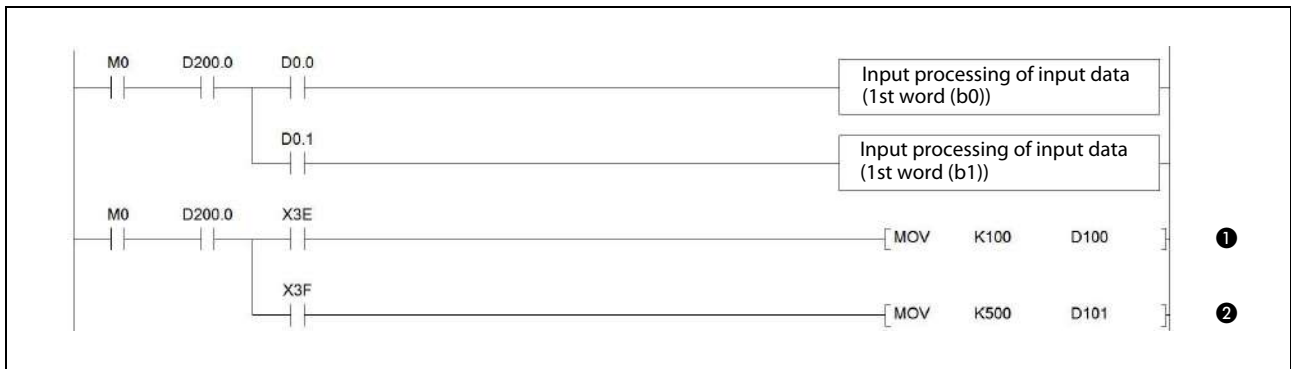

Fig. 7-8: Program example for control of DP-Slaves

No.	Description	
①	When both the ME1PB1-L (M0 = "1") and slave No. 1 (D200.0 = "1") are ready for communication, output data is written to the slave.	Writing to output data (1st word)
②		Writing to output data (2nd word)

Tab. 7-10: Description of fig. 7-8

● Program example for reading diagnostic information

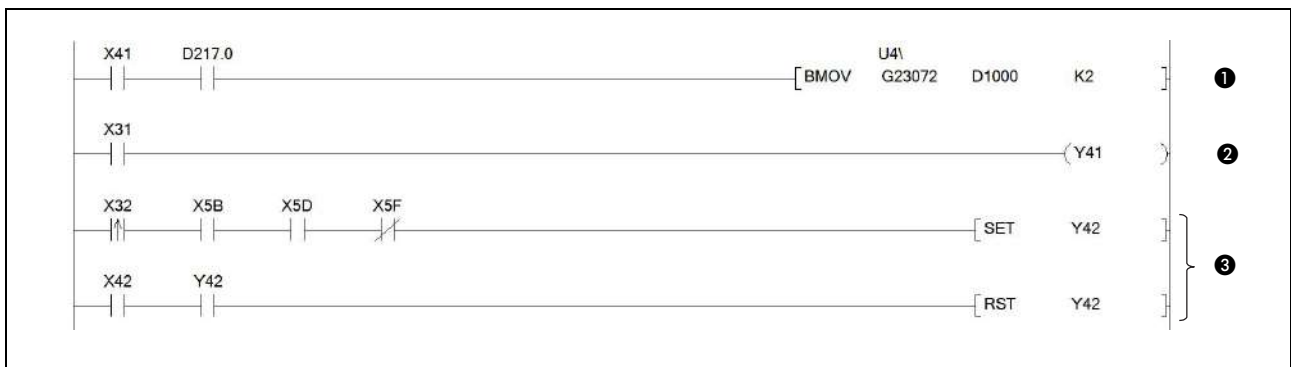

Fig. 7-9: Program example for reading diagnostic information

No.	Description
①	Reading the diagnostic information (1st module)
②	Diagnostic information detection reset request
③	Diagnostic information area clear request

Tab. 7-11: Description of fig. 7-9

● Program example for operation mode change (Self-diagnostics mode)

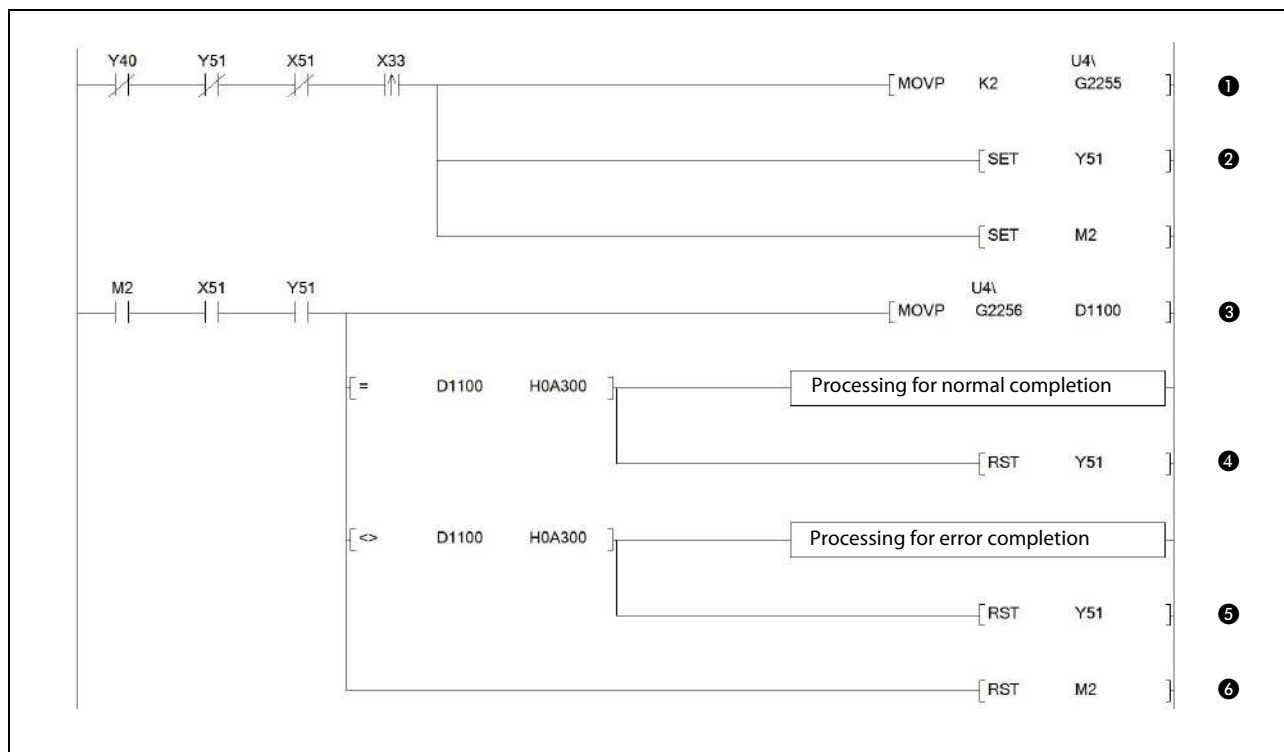

Fig. 7-10: Program example for operation mode change (self-diagnostics mode)

No.	Description
①	Writing of operation mode (Mode 2 = Self-diagnostic mode)
②	The operation mode change request (Y(n+1)1) is set.
③	The operation mode change result is read.
④	When the operation mode change is completed, the Operation mode change request is reset.
⑤	
⑥	M2, which is set during operation mode change, is reset upon completion of operation mode change.

Tab. 7-12: Description of fig. 7-10

7.1.2 Program example using dedicated instructions

This section explains a program in which the ME1PB1-L communicates with DP-Slaves using dedicated instructions.

This program example is based on the system configuration example shown in section 7.1.

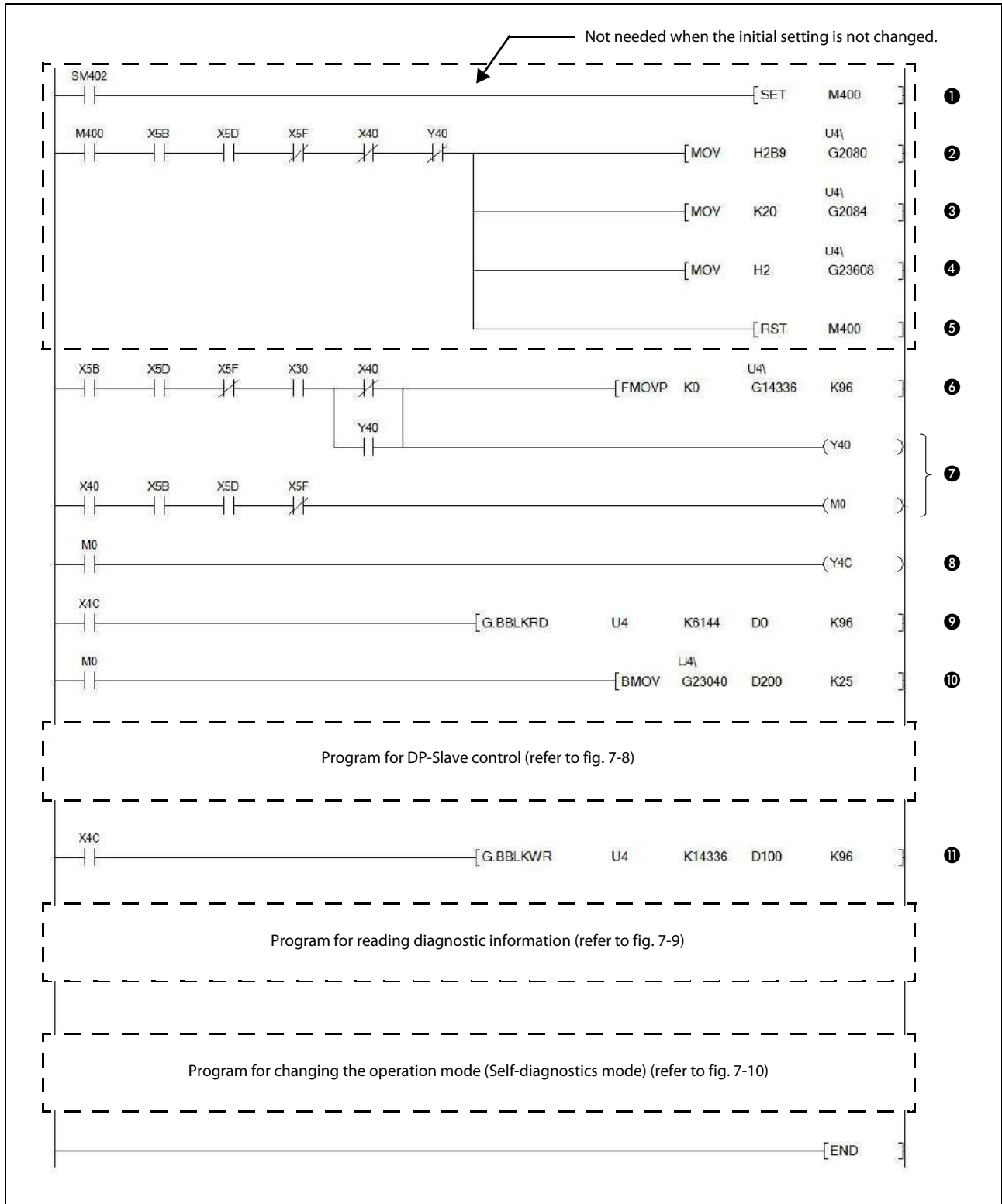

Fig. 7-11: I/O data exchange program example (dedicated instructions)

No.	Description
①	Turn ON the initial setting execution command
②	Initializes Diagnostic information invalid setting area
③	Initializes Diagnostic information non-notification time setting area
④	Specifies the 2nd temporary slave reservation
⑤	Turn OFF the initial setting execution command
⑥	Writes the initial output data value.
⑦	I/O data exchange start processing
⑧	Data consistency start request signal
⑨	BBLKRD execution (Reading input data)
⑩	Reads Slave status area
⑪	BBLKWR execution (Writing output data)

Tab. 7-13: Description of fig. 7-11

NOTE

Confirm that consistency is disabled with automatic refresh enabled. (Refer to section 6.3)
 When the automatic refresh and data consistency functions are enabled, dedicated instructions are not processed.

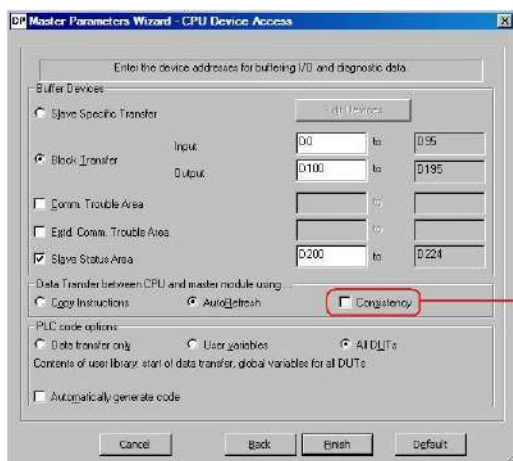

Make sure the checkbox is unchecked.

7.1.3 Program example using MOV instructions

This section explains a program in which the ME1PB1-L communicates with a DP-Slave using the MOV instruction.

This program example is based on the system configuration example shown in section 7.1.

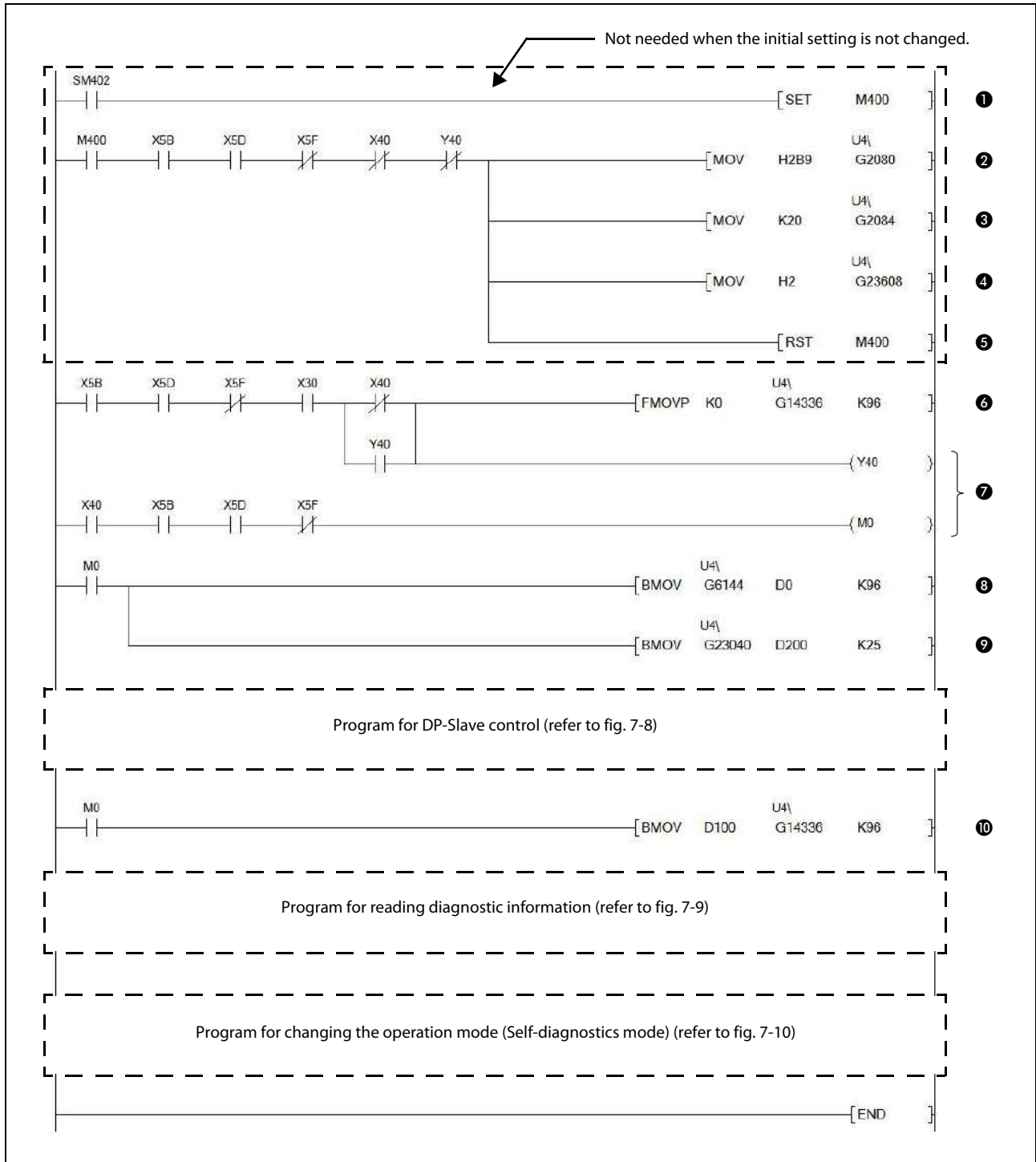

Fig. 7-12: I/O data exchange program example (MOV instructions)

No.	Description
①	Turn ON the initial setting execution command
②	Initializes Diagnostic information invalid setting area
③	Initializes Diagnostic information non-notification time setting area
④	Specifies the 2nd temporary slave reservation
⑤	Turn OFF the initial setting execution command
⑥	Writes the initial output data value.
⑦	I/O data exchange start processing
⑧	Reading input data
⑨	Reads Slave status area.
⑩	Writing output data

Tab. 7-14: Description of fig. 7-12

7.2 Program Example for Acquisition of Extended Diagnostic Error Information

Assignment of devices in program examples

The program example in this section uses the following device assignments.

- Devices occupied by the ME1PB1-L

Device (Input)	Description	Device (Output)	Description
X46	Extended diagnostic information read response signal	Y46	Extended diagnostic information read request signal

Tab. 7-15: List of devices for the ME1PB1-L

- Devices for the user

Device (Input)	Description	Device (Output)	Description
X34	Extended diagnostic information read command		—

Tab. 7-16: List of devices for the user

- Devices used as automatic refresh or buffer memory read target

Device	Description	Device	Description
D2000 to D2126*	Extended diagnostic error information read result		—
D2500 to D2502	For word conversion of extended diagnostic error information data size		

Tab. 7-17: List of devices used as automatic refresh or buffer memory read target

* Varies depending on the data size of the extended diagnostic error information.

Program example

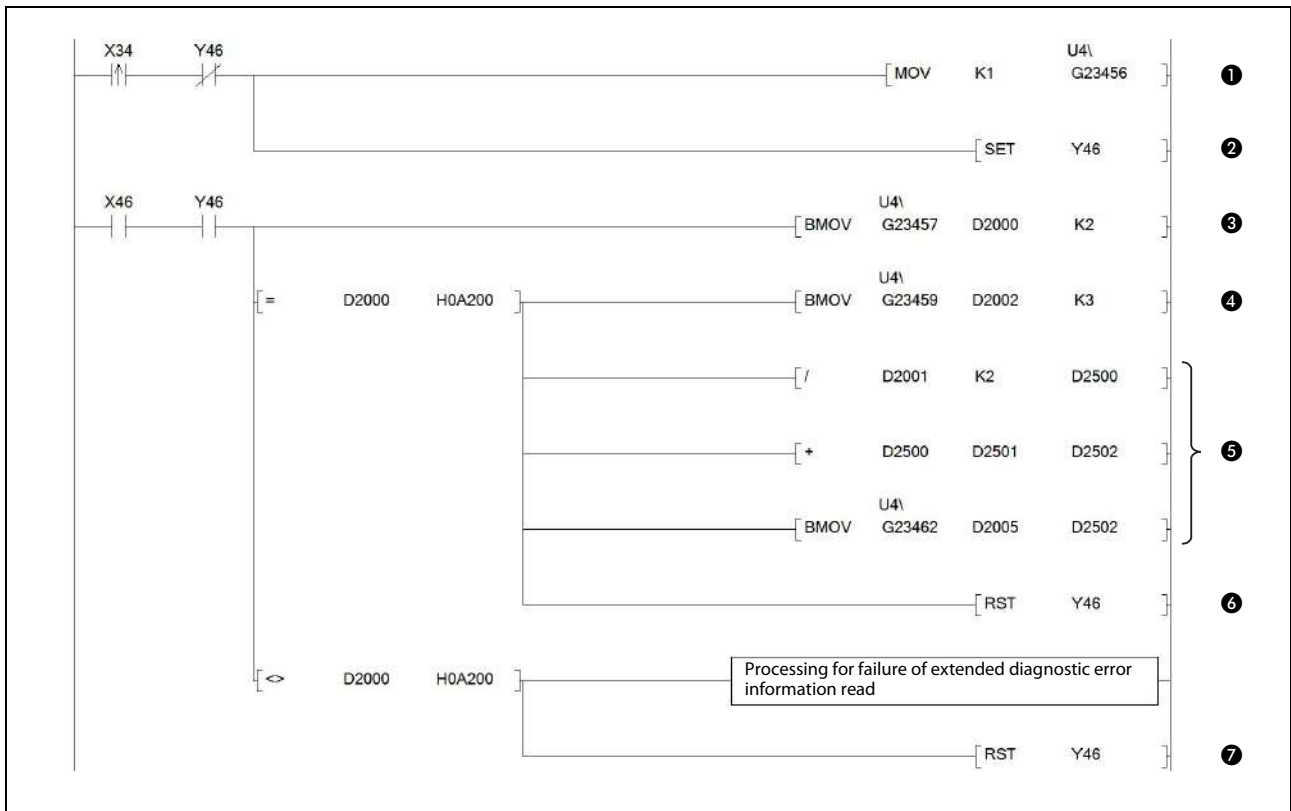

Fig. 7-13: Program example for acquisition of extended diagnostic error information

No.	Description
①	The target FDL address is set to 1.
②	Extended diagnostic information read request
③	The read result and data size is read.
④	Reads the status information and FDL address.
⑤	Reads the extended diagnostic error information.
⑥	When reading of the extended diagnostic error information is completed, the read request signal is reset.
⑦	

Tab. 7-18: Description of fig. 7-13

7.3 Program Example for Global Control Function

Assignment of devices in program examples

The program example in this section uses the following device assignments.

- Devices occupied by the ME1PB1-L

Device (Input)	Description	Device (Output)	Description
X44	Global control completed signal	Y44	Global control request signal
X45	Global control failed signal		—

Tab. 7-19: List of devices for the ME1PB1-L

- Devices for the user

Device	Description	Device	Description
X35	Global control execution command	M0	ME1PB1-L is ready for communication (refer to section 7.1.1)

Tab. 7-20: List of devices for the user

Program example

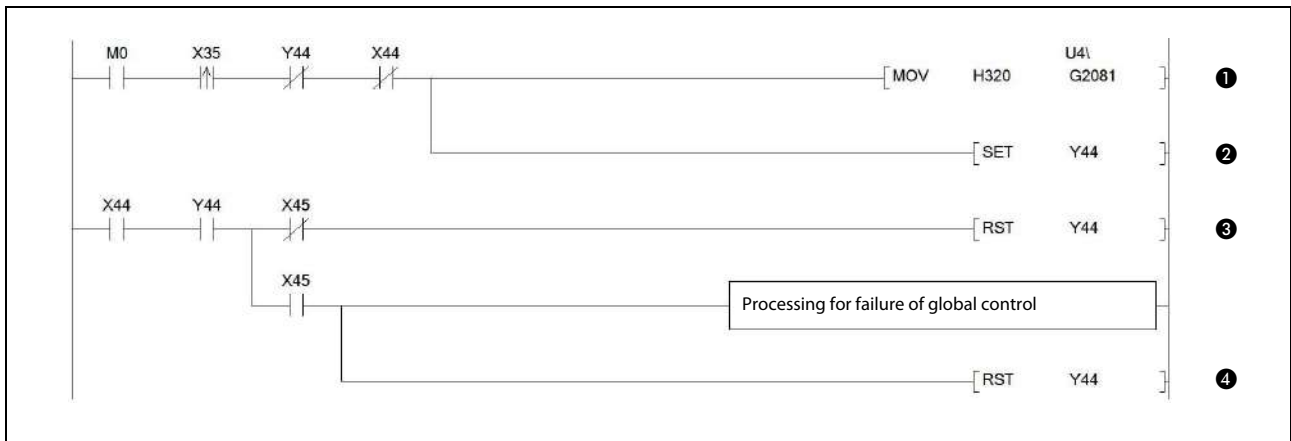

Fig. 7-14: Program example for global control function

No.	Description
①	Sends SYNC service to groups 1 and 2.
②	Global control request
③	When global control processing is completed, the request signal is reset.
④	

Tab. 7-21: Description of fig. 7-14

7.4 Program Example for Acyclic Communication with DP-Slaves

The following explains the request and response formats in acyclic communications, providing a program example.

The request and response formats in this section employ offset addresses (in word units). The "offset address" refers to the n-th data in word units starting from the start address of the request instruction No. area to be used.

Request instruction No.	Start address of acyclic communication request area	Start address of acyclic communication response area
Request instruction No.1	23809 (5D01H)	25121 (6221H)
Request instruction No.2	23937 (5D81H)	25249 (62A1H)
Request instruction No.3	24065 (5E01H)	25377 (6321H)
Request instruction No.4	24193 (5E81H)	25505 (63A1H)
Request instruction No.5	24321 (5F01H)	25633 (6421H)
Request instruction No.6	24449 (5F81H)	25761 (64A1H)
Request instruction No.7	24578 (6001H)	25889 (6521H)
Request instruction No.8	24705 (6081H)	26017 (65A1H)

Tab. 7-22: List of start addresses in request instruction no. areas

Making a sequence program

The following example program is created for executing request instruction No.1.

For details on the program example, refer to section 7.4.5.

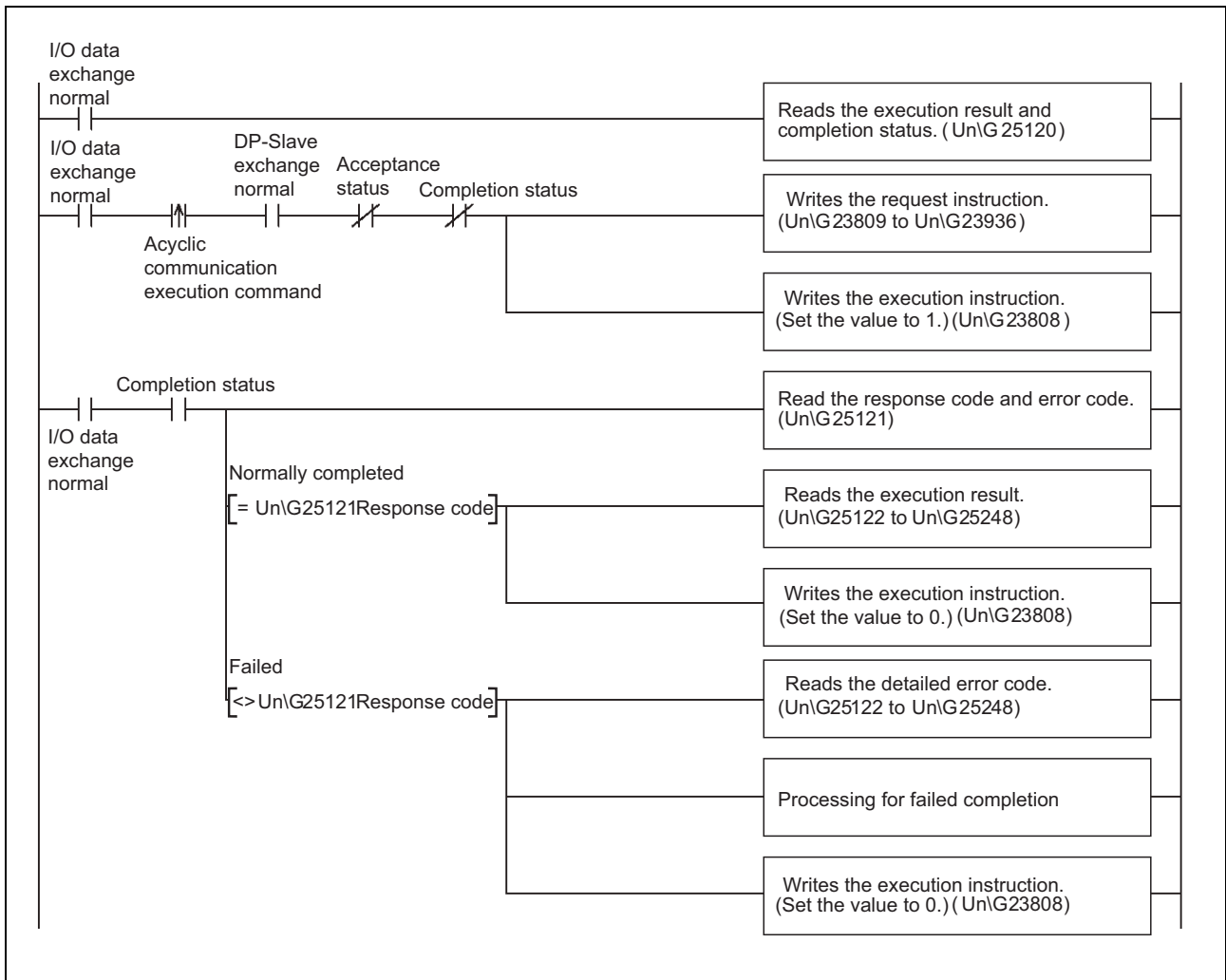

Fig. 7-15: Sequence program (acyclic communication)

7.4.1 READ services (Class1_SERVICE, Class2_SERVICE)

This section explains the request and response formats of the READ services (Class1_SERVICE, Class2_SERVICE).

Request format

Offset address	Description/Set value																
+ 0 (+ 0H)	Set a request code. <ul style="list-style-type: none"> In READ service (Class1_SERVICE) Set value: 1400H In READ service (Class2_SERVICE) Set value: 1410H 																
+ 1 (+ 1H)	<ul style="list-style-type: none"> In READ service (Class1_SERVICE) <table border="1" style="margin-left: 20px;"> <tr> <td style="text-align: center;">b15</td> <td style="text-align: center;">b8</td> <td style="text-align: center;">b7</td> <td style="text-align: center;">b0</td> </tr> <tr> <td style="text-align: center;">0</td> <td colspan="3" style="text-align: center;">①</td> </tr> </table> <ul style="list-style-type: none"> ① Set the FDL address of the target DP-Slave Set value: 00H to 7DH (0 to 125) In READ service (Class2_SERVICE) <table border="1" style="margin-left: 20px;"> <tr> <td style="text-align: center;">b15</td> <td style="text-align: center;">b8</td> <td style="text-align: center;">b7</td> <td style="text-align: center;">b0</td> </tr> <tr> <td colspan="2" style="text-align: center;">②</td> <td colspan="2" style="text-align: center;">①</td> </tr> </table> <ul style="list-style-type: none"> ① Set the FDL address of the target DP-Slave Set value: 00H to 7DH (0 to 125) ② Set "CommRef No." contained in the response format of the INITIATE service Set value: 00H to 7EH (0 to 126) 	b15	b8	b7	b0	0	①			b15	b8	b7	b0	②		①	
b15	b8	b7	b0														
0	①																
b15	b8	b7	b0														
②		①															
+ 2 (+ 2H)	Set the length of the data to read. (Unit: byte) Set value: 1 to 240																
+ 3 (+ 3H)	Set the slot No. to read. Set value: 0 to 254																
+ 4 (+ 4H)	Set the index to read. Set value: 0 to 255																
+ 5 (+ 5H) to +127 (+7FH)	Empty area (Write 0000H.) Set value: Fixed to 0000H																

Tab. 7-23: Request format

Response format

- When normally completed

Offset address	Result																									
+ 0 (+ 0H)	<p>A response code is stored.</p> <ul style="list-style-type: none"> • In READ service (Class1_SERVICE) Stored value: A400H • In READ service (Class2_SERVICE) Stored value: A410H 																									
+ 1 (+ 1H)	<ul style="list-style-type: none"> • In READ service (Class1_SERVICE) <table border="1" style="margin-left: 40px;"> <tr> <td style="text-align: center;">b15</td> <td style="text-align: center;">b8</td> <td style="text-align: center;">b7</td> <td style="text-align: center;">b0</td> </tr> <tr> <td style="text-align: center;">0</td> <td colspan="3" style="text-align: center;">①</td> </tr> </table> <ul style="list-style-type: none"> ① The FDL address of the DP-Slave is stored. Stored value: 00H to 7DH (0 to 125) • In READ service (Class2_SERVICE) <table border="1" style="margin-left: 40px;"> <tr> <td style="text-align: center;">b15</td> <td style="text-align: center;">b8</td> <td style="text-align: center;">b7</td> <td style="text-align: center;">b0</td> </tr> <tr> <td colspan="2" style="text-align: center;">②</td> <td colspan="2" style="text-align: center;">①</td> </tr> </table> <ul style="list-style-type: none"> ① The FDL address of the DP-Slave is stored. Stored value: 00H to 7DH (0 to 125) ② The CommRef No. is stored. Stored value: 00H to 7EH (0 to 126) 	b15	b8	b7	b0	0	①			b15	b8	b7	b0	②		①										
b15	b8	b7	b0																							
0	①																									
b15	b8	b7	b0																							
②		①																								
+ 2 (+ 2H)	<p>The length of the read data is stored. (Unit: byte) Stored value: 1 to 240</p>																									
+ 3 (+ 3H)	<p>The read slot No. is stored. Stored value: 0 to 254</p>																									
+ 4 (+ 4H)	<p>The read index is stored. Stored value: 0 to 255</p>																									
+ 5 (+ 5H) to +124 (+7CH)	<p>The read data are stored. When the read data length is shorter than the length specified in the request format, 0s are stored in the empty area. When the read data length is longer than the length specified in the request format, only data of the specified data length are stored.</p> <table border="1" style="margin-left: 40px;"> <tr> <td></td> <td style="text-align: center;">b15</td> <td style="text-align: center;">b8</td> <td style="text-align: center;">b7</td> <td style="text-align: center;">b0</td> </tr> <tr> <td>+ 5 (+ 5H)</td> <td colspan="2" style="text-align: center;">Data 2</td> <td colspan="2" style="text-align: center;">Data 1</td> </tr> <tr> <td>+ 6 (+ 6H)</td> <td colspan="2" style="text-align: center;">Data 4</td> <td colspan="2" style="text-align: center;">Data 3</td> </tr> <tr> <td style="text-align: center;">⋮</td> <td colspan="2" style="text-align: center;">⋮</td> <td colspan="2" style="text-align: center;">⋮</td> </tr> <tr> <td>+ 124 (+ 7CH)</td> <td colspan="2" style="text-align: center;">Data 240</td> <td colspan="2" style="text-align: center;">Data 239</td> </tr> </table>		b15	b8	b7	b0	+ 5 (+ 5H)	Data 2		Data 1		+ 6 (+ 6H)	Data 4		Data 3		⋮	⋮		⋮		+ 124 (+ 7CH)	Data 240		Data 239	
	b15	b8	b7	b0																						
+ 5 (+ 5H)	Data 2		Data 1																							
+ 6 (+ 6H)	Data 4		Data 3																							
⋮	⋮		⋮																							
+ 124 (+ 7CH)	Data 240		Data 239																							
+125 (+7DH) to +127 (+7FH)	<p>Empty area Stored value: 0000H</p>																									

Tab. 7-24: Response format (when normally completed)

● When failed

Offset address	Result																
+ 0 (+ 0H)	An error code is stored. (Refer to section 9.4.3)																
+ 1 (+ 1H)	<ul style="list-style-type: none"> In READ service (Class2_SERVICE) <table border="1" style="margin-left: 20px;"> <tr> <td style="text-align: center;">b15</td> <td style="text-align: center;">b8</td> <td style="text-align: center;">b7</td> <td style="text-align: center;">b0</td> </tr> <tr> <td style="text-align: center;">0</td> <td colspan="2" style="text-align: center;">1</td> <td></td> </tr> </table> <ul style="list-style-type: none"> 1 The FDL address of the DP-Slave is stored. Stored value: 00H to 7DH (0 to 125) In READ service (Class2_SERVICE) <table border="1" style="margin-left: 20px;"> <tr> <td style="text-align: center;">b15</td> <td style="text-align: center;">b8</td> <td style="text-align: center;">b7</td> <td style="text-align: center;">b0</td> </tr> <tr> <td style="text-align: center;">2</td> <td colspan="2" style="text-align: center;">1</td> <td></td> </tr> </table> <ul style="list-style-type: none"> 1 The FDL address of the DP-Slave is stored. Stored value: 00H to 7DH (0 to 125) 2 The CommRef No. is stored. Stored value: 00H to 7EH (0 to 126) 	b15	b8	b7	b0	0	1			b15	b8	b7	b0	2	1		
b15	b8	b7	b0														
0	1																
b15	b8	b7	b0														
2	1																
+ 2 (+ 2H)	<ul style="list-style-type: none"> When E403H is currently stored in offset address +0 (+0H) Detailed error code 1 is stored. (Refer to section 9.4.3) When a value other than E403H is currently stored in offset address +0 (+0H) Stored value: FFFFH (No detailed error code 1) 																
+ 3 (+ 3H)	<ul style="list-style-type: none"> When E403H is currently stored in offset address +0 (+0H) Detailed error code 2 is stored. (Refer to section 9.4.3) When a value other than E403H is currently stored in offset address +0 (+0H) Stored value: FFFFH (No detailed error code 2) 																
+ 4 (+ 4H)	<ul style="list-style-type: none"> When E403H is currently stored in offset address +0 (+0H) Detailed error code 3 is stored. (Refer to section 9.4.3) When a value other than E403H is currently stored in offset address +0 (+0H) Stored value: FFFFH (No detailed error code 3) 																
+ 5 (+ 5H) to +127 (+7FH)	Empty area Stored value: 0000H																

Tab. 7-25: Response format (when failed)

7.4.2 WRITE services (Class1_SERVICE, Class2_SERVICE)

This section explains the request and response formats of the WRITE services (Class1_SERVICE, Class2_SERVICE).

Request format

Offset address	Description/Set value																				
+ 0 (+ 0H)	Set a request code. <ul style="list-style-type: none"> In WRITE service (Class1_SERVICE) Set value: 1401H In WRITE service (Class2_SERVICE) Set value: 1411H 																				
+ 1 (+ 1H)	<ul style="list-style-type: none"> In WRITE service (Class1_SERVICE) <table border="1" style="margin-left: 20px;"> <tr> <td style="width: 80px;">b15</td> <td style="width: 80px;">b8 b7</td> <td style="width: 80px;">b0</td> </tr> <tr> <td style="text-align: center;">0</td> <td style="text-align: center;">①</td> <td></td> </tr> </table> <ul style="list-style-type: none"> ① Set the FDL address of the target DP-Slave. Set value : 00H to 7DH (0 to 125) In WRITE service (Class2_SERVICE) <table border="1" style="margin-left: 20px;"> <tr> <td style="width: 80px;">b15</td> <td style="width: 80px;">b8 b7</td> <td style="width: 80px;">b0</td> </tr> <tr> <td style="text-align: center;">②</td> <td style="text-align: center;">①</td> <td></td> </tr> </table> <ul style="list-style-type: none"> ① Set the FDL address of the target DP-Slave. Set value : 00H to 7DH (0 to 125) ② Set CommRef No. contained in the response format of the INITIATE service. Set value : 00H to 7EH (0 to 126) 	b15	b8 b7	b0	0	①		b15	b8 b7	b0	②	①									
b15	b8 b7	b0																			
0	①																				
b15	b8 b7	b0																			
②	①																				
+ 2 (+ 2H)	Set the length of the data to write. (Unit: byte) Set value: 1 to 240																				
+ 3 (+ 3H)	Set the slot No. to write. Set value: 0 to 254																				
+ 4 (+ 4H)	Set the index to write. Set value: 0 to 255																				
+ 5 (+ 5H) to +124 (+7CH)	Set the data to write. <table border="1" style="margin-left: 20px;"> <tr> <td style="width: 80px;"></td> <td style="width: 80px;">b15</td> <td style="width: 80px;">b8 b7</td> <td style="width: 80px;">b0</td> </tr> <tr> <td>+5 (+5H)</td> <td style="text-align: center;">Data 2</td> <td style="text-align: center;">Data 1</td> <td></td> </tr> <tr> <td>+6 (+6H)</td> <td style="text-align: center;">Data 4</td> <td style="text-align: center;">Data 3</td> <td></td> </tr> <tr> <td style="text-align: center;">to</td> <td style="border: none;">⋮</td> <td style="border: none;">⋮</td> <td style="border: none;">⋮</td> </tr> <tr> <td>124 (+7CH)</td> <td style="text-align: center;">Data 240</td> <td style="text-align: center;">Data 239</td> <td></td> </tr> </table>		b15	b8 b7	b0	+5 (+5H)	Data 2	Data 1		+6 (+6H)	Data 4	Data 3		to	⋮	⋮	⋮	124 (+7CH)	Data 240	Data 239	
	b15	b8 b7	b0																		
+5 (+5H)	Data 2	Data 1																			
+6 (+6H)	Data 4	Data 3																			
to	⋮	⋮	⋮																		
124 (+7CH)	Data 240	Data 239																			
+125 (+7DH) to +127 (+7FH)	Empty area (Write 0000H.) Set value: Fixed to 0000H																				

Tab. 7-26: Request format

Response format

- When normally completed

Offset address	Result												
+ 0 (+ 0H)	<p>A response code is stored.</p> <ul style="list-style-type: none"> • In WRITE service (Class1_SERVICE) Stored value: A401H • In WRITE service (Class2_SERVICE) Stored value: A411H 												
+ 1 (+ 1H)	<ul style="list-style-type: none"> • In WRITE service (Class1_SERVICE) <table border="1" style="width: 100%; border-collapse: collapse;"> <tr> <td style="text-align: center;">b15</td> <td style="text-align: center;">b8 b7</td> <td style="text-align: center;">b0</td> </tr> <tr> <td style="text-align: center;">0</td> <td style="text-align: center;">①</td> <td></td> </tr> </table> <p>① The FDL address of the DP-Slave is stored. Stored value : 00H to 7DH (0 to 125)</p> • In WRITE service (Class2_SERVICE) <table border="1" style="width: 100%; border-collapse: collapse;"> <tr> <td style="text-align: center;">b15</td> <td style="text-align: center;">b8 b7</td> <td style="text-align: center;">b0</td> </tr> <tr> <td style="text-align: center;">②</td> <td style="text-align: center;">①</td> <td></td> </tr> </table> <p>① The FDL address of the DP-Slave is stored. Stored value : 00H to 7DH (0 to 125)</p> <p>② The CommRef No. is stored. Stored value : 00H to 7EH (0 to 126)</p> 	b15	b8 b7	b0	0	①		b15	b8 b7	b0	②	①	
b15	b8 b7	b0											
0	①												
b15	b8 b7	b0											
②	①												
+ 2 (+ 2H)	<p>The length of the written data is stored. (Unit: byte) Set value: 1 to 240</p>												
+ 3 (+ 3H)	<p>Set the written slot No. Set value: 0 to 254</p>												
+ 4 (+ 4H)	<p>Set the written index. Set value: 0 to 255</p>												
+ 5 (+ 5H) to +127 (+7FH)	<p>Empty area Stored value: 0000H</p>												

Tab. 7-27: Response format (when normally completed)

● When failed

Offset address	Result																				
+ 0 (+ 0H)	An error code is stored.(Refer to section 9.4.3)																				
+ 1 (+ 1H)	<ul style="list-style-type: none"> In WRITE service (Class1_SERVICE) <div style="margin-left: 20px;"> <table style="border-collapse: collapse; width: 100%;"> <tr> <td style="text-align: right; width: 15%;">b15</td> <td style="width: 40%;"></td> <td style="text-align: center; width: 15%;">b8 b7</td> <td style="width: 15%;"></td> <td style="text-align: left; width: 15%;">b0</td> </tr> <tr> <td></td> <td style="border: 1px solid black; text-align: center;">0</td> <td style="border: 1px solid black; text-align: center;">①</td> <td></td> <td></td> </tr> </table> </div> <ul style="list-style-type: none"> ① The FDL address of the DP-Slave is stored. Stored value : 00H to 7DH (0 to 125) In WRITE service (Class2_SERVICE) <div style="margin-left: 20px;"> <table style="border-collapse: collapse; width: 100%;"> <tr> <td style="text-align: right; width: 15%;">b15</td> <td style="width: 40%;"></td> <td style="text-align: center; width: 15%;">b8 b7</td> <td style="width: 15%;"></td> <td style="text-align: left; width: 15%;">b0</td> </tr> <tr> <td></td> <td style="border: 1px solid black; text-align: center;">②</td> <td style="border: 1px solid black; text-align: center;">①</td> <td></td> <td></td> </tr> </table> </div> <ul style="list-style-type: none"> ① The FDL address of the DP-Slave is stored. Stored value : 00H to 7DH (0 to 125) ② The CommRef No. is stored. Stored value : 00H to 7EH (0 to 126) 	b15		b8 b7		b0		0	①			b15		b8 b7		b0		②	①		
b15		b8 b7		b0																	
	0	①																			
b15		b8 b7		b0																	
	②	①																			
+ 2 (+ 2H)	<ul style="list-style-type: none"> When E443H is currently stored in offset address +0 (+0H) Detailed error code 1 is stored. (Refer to section 9.4.3) When a value other than E443H is currently stored in offset address +0 (+0H) Stored value: FFFFH (No detailed error code 1) 																				
+ 3 (+ 3H)	<ul style="list-style-type: none"> When E443H is currently stored in offset address +0 (+0H) Detailed error code 2 is stored. (Refer to section 9.4.3) When a value other than E443H is currently stored in offset address +0 (+0H) Stored value: FFFFH (No detailed error code 2) 																				
+ 4 (+ 4H)	<ul style="list-style-type: none"> When E443H is currently stored in offset address +0 (+0H) Detailed error code 3 is stored. (Refer to section 9.4.3) When a value other than E443H is currently stored in offset address +0 (+0H) Stored value: FFFFH (No detailed error code 3) 																				
+ 5 (+ 5H) to +127 (+7FH)	Empty area Stored value: 0000H																				

Tab. 7-28: Response format (when failed)

7.4.3 INITIATE service (Class2_SERVICE)

This section explains the request and response formats of the INITIATE service (Class2_SERVICE).

Request format

Offset address	Description/Set value
+ 0 (+ 0H)	Set a request code. Set value: 1412H
+ 1 (+ 1H)	Set the FDL address of the DP-Slave to which the network line is connected. Set value: 0000H to 007DH(0 to 125)
+ 2 (+ 2H)	Set a transmission timeout value. (Unit: 10ms) The setting range differs depending on the DP-Slave specifications. Check the DP-Slave specifications. Set value: 0 to 65535
+ 3 (+ 3H)	Set Alignment. The setting range differs depending on the DP-Slave specifications. Check the DP-Slave specifications. Set value: Fixed to 0000H
+ 4 (+ 4H)	Set Features Supported. The setting range differs depending on the DP-Slave specifications. Check the DP-Slave specifications. Set value: Fixed to 0001H
+ 5 (+ 5H)	Set Profile Features Supported. The setting range differs depending on the DP-Slave specifications. Check the DP-Slave specifications. Set value: Fixed to 0000H
+ 6 (+ 6H)	Set Profile Ident Number. The setting range differs depending on the DP-Slave specifications. Check the DP-Slave specifications. Set value: Fixed to 0000H
+ 7 (+ 7H)	<div style="text-align: center;"> </div> <p> 1 Set S_Type. The setting range differs depending on the DP-Slave specifications. Check the DP-Slave specifications. Set value : Fixed to 00H </p> <p> 2 Set S_Len. The setting range differs depending on the DP-Slave specifications. Check the DP-Slave specifications. Set value : Fixed to 00H </p>
+ 8 (+ 8H)	<div style="text-align: center;"> </div> <p> 1 Sets D_Type. The setting range differs depending on the DP-Slave specifications. Check the DP-Slave specifications. Set value : Fixed to 00H </p> <p> 2 Set D_Len. The setting range differs depending on the DP-Slave specifications. Check the DP-Slave specifications. Set value : Fixed to 00H </p>
+ 9 (+ 9H) to +127 (+7FH)	Empty area (Write 0000H.) Set value: Fixed to 0000H

Tab. 7-29: Request format

Response format

- When normally completed

Offset address	Result
+ 0 (+ 0H)	A response code is stored. Stored value: A412H
+ 1 (+ 1H)	<div style="text-align: center;"> </div> <ul style="list-style-type: none"> ① The FDL address of the DP-Slave connected to the network is stored. Stored value : 00H to 7DH (0 to 125) ② The CommRef No. is stored. Stored value : 00H to 7EH (0 to 126)
+ 2 (+ 2H)	Max LenDataUnit is stored. The stored value differs depending on the DP-Slave specifications. Check the DP-Slave specifications.
+ 3 (+ 3H)	Features Supported is stored. The stored value differs depending on the DP-Slave specifications. Check the DP-Slave specifications.
+ 4 (+ 4H)	Profile Features Supported is stored. The stored value differs depending on the DP-Slave specifications. Check the DP-Slave specifications.
+ 5 (+ 5H)	Profile Ident Number is stored. The stored value differs depending on the DP-Slave specifications. Check the DP-Slave specifications.
+ 6 (+ 6H)	<div style="text-align: center;"> </div> <ul style="list-style-type: none"> ① S_Type is stored. The stored value differs depending on the DP-Slave specifications. Check the DP-Slave specifications. ② S_Len is stored. The stored value differs depending on the DP-Slave specifications. Check the DP-Slave specifications.
+ 7 (+ 7H)	<div style="text-align: center;"> </div> <ul style="list-style-type: none"> ① D_Type is stored. The stored value differs depending on the DP-Slave specifications. Check the DP-Slave specifications. ② D_Len is stored. The stored value differs depending on the DP-Slave specifications. Check the DP-Slave specifications.
+ 8 (+ 8H) to +127 (+7FH)	Empty area Stored value: 0000H

Tab. 7-30: Response format (when normally completed)

● When failed

Offset address	Result
+ 0 (+ 0H)	An error code is stored. (Refer to section 9.4.3)
+ 1 (+ 1H)	<div style="text-align: center;"> </div> <p> 1 The FDL address of the DP-Slave connected to the network is stored. Stored value : 00H to 7DH (0 to 125) </p> <p> 2 The CommRef No. is stored. Stored value : 00H to 7EH (0 to 126) </p>
+ 2 (+ 2H)	<ul style="list-style-type: none"> When E482H is currently stored in offset address +0 (+0H) Detailed error code 1 is stored. (Refer to section 9.4.3) When a value other than E482H is currently stored in offset address +0 (+0H) Stored value: FFFFH (No detailed error code 1)
+ 3 (+ 3H)	<ul style="list-style-type: none"> When E482H is currently stored in offset address +0 (+0H) Detailed error code 2 is stored. (Refer to section 9.4.3) When a value other than E482H is currently stored in offset address +0 (+0H) Stored value: FFFFH (No detailed error code 2)
+ 4 (+ 4H)	<ul style="list-style-type: none"> When E482H is currently stored in offset address +0 (+0H) Detailed error code 2 is stored. (Refer to section 9.4.3) When a value other than E482H is currently stored in offset address +0 (+0H) Stored value: FFFFH (No detailed error code 3)
+ 5 (+ 5H) to +127 (+7FH)	Empty area Stored value: 0000H

Tab. 7-31: Response format (when failed)

7.4.4 ABORT service (Class2_SERVICE)

This section explains the request and response formats of the ABORT service (Class2_SERVICE).

Request format

Offset address	Description/Set value
+ 0 (+ 0H)	Set a request code. Set value: 1413H
+ 1 (+ 1H)	<div style="text-align: center;"> </div> <p> 1 The FDL address of the DP-Slave to be connected to network is stored. Set value : 00H to 7DH (0 to 125) </p> <p> 2 Set the CommRef No. contained in the response format of the INITIATE service. Set value : 00H to 7EH (0 to 126) </p>
+ 2 (+ 2H)	<div style="text-align: center;"> </div> <p> 1 Set Instance Reason. The setting range differs depending on the DP-Slave specifications. Check the DP-Slave specifications. Set value : Fixed to 00H </p> <p> 2 Set Subnet. The setting range differs depending on the DP-Slave specifications. Check the DP-Slave specifications. Set value : Fixed to 30H </p>
+ 3 (+ 3H) to +127 (+7FH)	Empty area (Write 0000H.) Set value: Fixed to 0000H

Tab. 7-32: Request format

Response format

- When normally completed

Offset address	Result
+ 0 (+ 0H)	A response code is stored. Stored value: A413H
+ 1 (+ 1H)	<div style="display: flex; justify-content: space-between; align-items: center;"> b15 b8 b7 b0 </div>  <ul style="list-style-type: none"> ❶ The FDL address of the DP-Slave connected to the network is stored. Stored value : 00H to 7DH (0 to 125) ❷ The CommRef No. is stored. Stored value : 00H to 7EH (0 to 126)
+ 2 (+ 2H) to +127 (+7FH)	Empty area Stored value: 0000H

Tab. 7-33: Response format (when normally completed)

- When failed

Offset address	Result
+ 0 (+ 0H)	An error code is stored. (Refer to section 9.4.3)
+ 1 (+ 1H)	<div style="display: flex; justify-content: space-between; align-items: center;"> b15 b8 b7 b0 </div>  <ul style="list-style-type: none"> ❶ The FDL address of the DP-Slave connected to the network is stored. Stored value : 00H to 7DH (0 to 125) ❷ The CommRef No. is stored. Stored value : 00H to 7EH (0 to 126)
+ 2 (+ 2H) to +127 (+7FH)	Empty area Stored value: 0000H

Tab. 7-34: Response format (when failed)

7.4.5 Program example

Settings

The example program in this section uses the following example requests.

Item	Description
Request instruction No.	Request instruction No.1
Service name	READ service (Class1_SERVICE)
DP-Slave FDL address	FDL address 2
Data length	16 bytes
Slot No.	0
Index	1

Tab. 7-35: Details of program example

Assignment of devices in program example

The program example in this section uses the following device assignments.

- Devices for the user

Device	Description	Device	Description
X26	Acyclic communication execution command	M0	ME1PB1-L is ready for communication (Refer to section 7.1.1)

Tab. 7-36: List of devices for the user

- Devices used as automatic refresh or buffer memory read target

Device	Description	Device	Description
D200 to D207	Slave status area (Normal communication detection)	M100 to M115	Acyclic communication request result area
D3000 to D3012	Acyclic communication response area		—

Tab. 7-37: List of devices used as automatic refresh or buffer memory read target

Program example

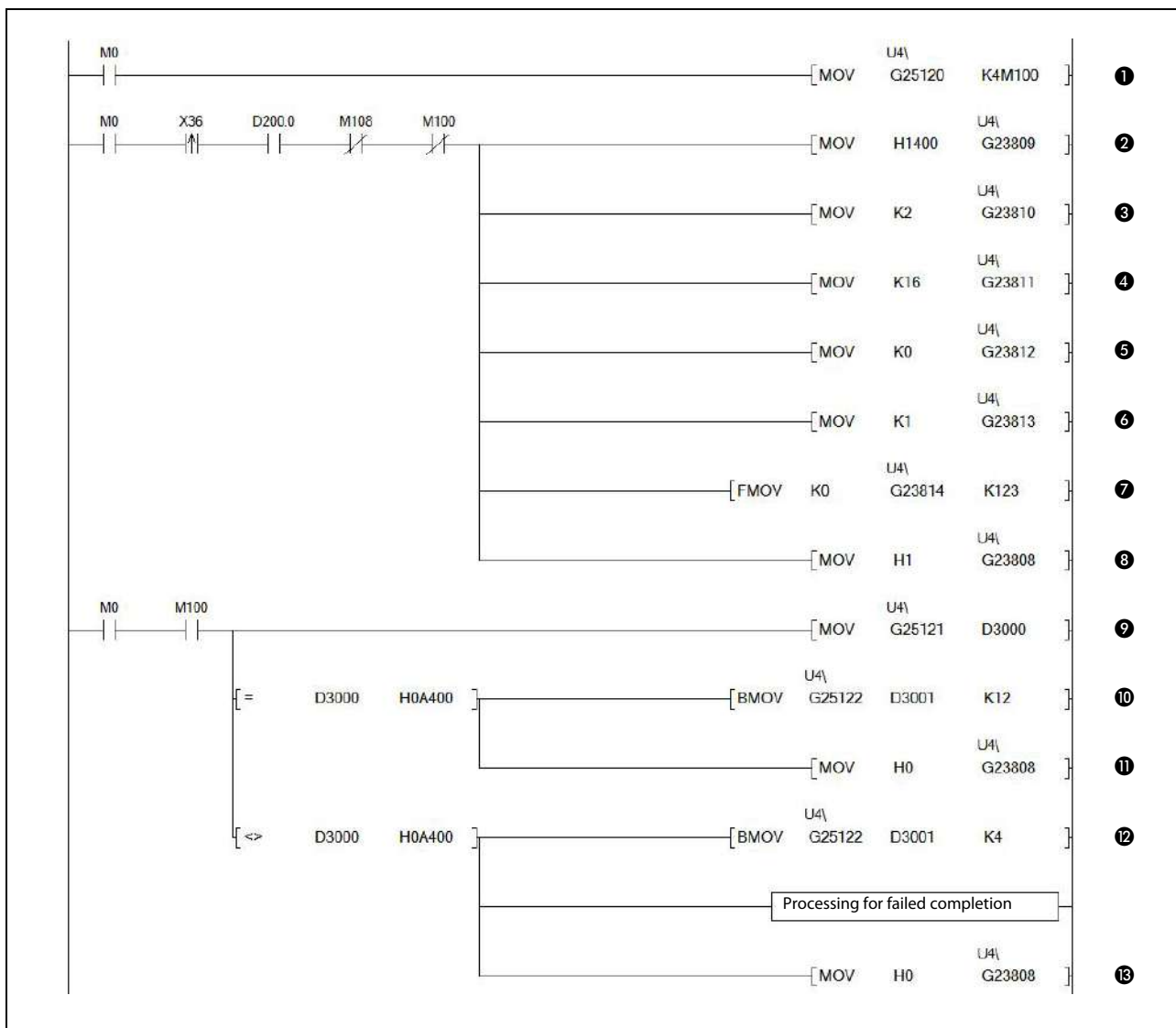

Fig. 7-16: Program example for acyclic communication (READ service (Class1_SERVICE))

No.	Description
①	Reads the acceptance status and completion status
②	Request code is set. (1400H)
③	The FDL address of the target DP-Slave is set. (FDL address 2)
④	Data length is set. (16 bytes)
⑤	Slot No. is set. (0)
⑥	Index is set. (1)
⑦	Empty area (0)
⑧	Executes Acyclic communication (Request instruction No.1 is executed.)
⑨	Reads the response code and error code
⑩	Reads the execution result
⑪	Acyclic communication completion processing
⑫	Reads detailed error code
⑬	Acyclic communication completion processing

Tab. 7-38: Description of fig. 7-16

7.5 Program Example for Alarm Acquisition

The following explains the request and response formats in alarm acquisition, providing a program example.

Making a sequence program

For details on the program example, refer to section 7.5.4.

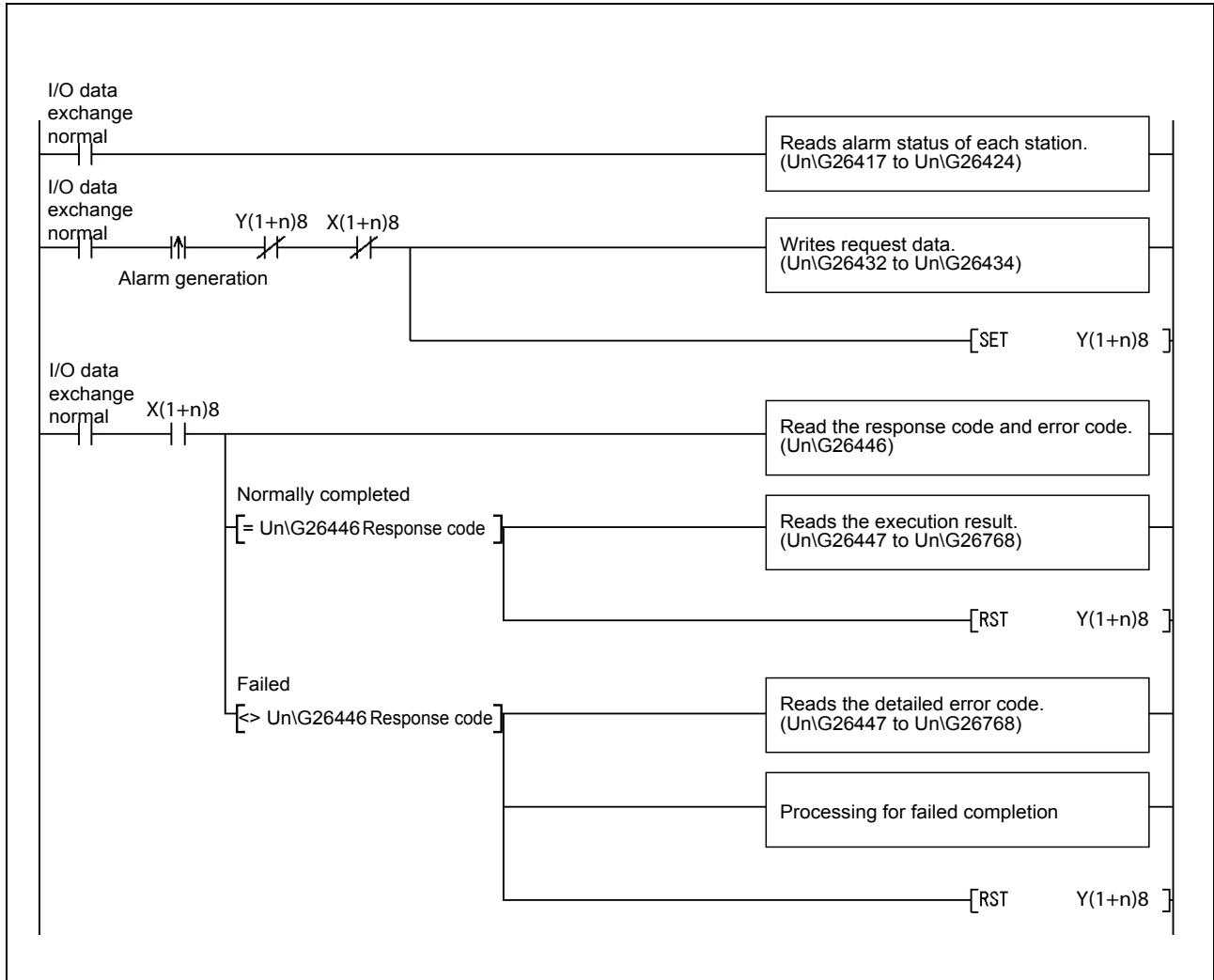

Fig. 7-17: Sequence program (alarm acquisition)

7.5.1 Alarm read request (without ACK)

This section explains the request and response formats of the alarm read request (without ACK).

Request format

Buffer memory address	Description/Set value
26432 (6740H)	Set a request code. Set value: 1500H
26433 (6741H)	Set the FDL address of the DP-Slave whose alarm is to be read. Set value: 0000H to 007DH (0 to 125)
26434 (6742H)	Empty area (Write 0000H.) Set value: Fixed to 0000H

Tab. 7-39: Request format

Response format

- When normally completed

Buffer memory address	Result																																
26446 (674EH)	A response code is stored. Stored value: A500H																																
26447 (674FH)	The FDL address of the DP-Slave from which alarm was read is stored. Stored value: 0000H to 007DH (0 to 125)																																
26448 (6750H)	<p>The read completion status of the alarm data is stored.</p> <table border="1" style="margin-left: 20px;"> <tr> <td style="text-align: center;">b15</td> <td style="text-align: center;">to</td> <td style="text-align: center;">b8</td> <td style="text-align: center;">b7</td> <td style="text-align: center;">to</td> <td style="text-align: center;">b0</td> </tr> <tr> <td style="text-align: center;">0</td> <td></td> <td></td> <td></td> <td></td> <td style="text-align: center;">See below.</td> </tr> </table> <table border="1" style="margin-left: 20px; width: 100%;"> <thead> <tr> <th>Bit</th> <th>Description</th> <th>Bit</th> <th>Description</th> </tr> </thead> <tbody> <tr> <td>b0</td> <td>Read completion status of alarm data No.1 0: Failed or not executed 1: Normally completed</td> <td>b4</td> <td>Read completion status of alarm data No.5 0: Failed or not executed 1: Normally completed</td> </tr> <tr> <td>b1</td> <td>Read completion status of alarm data No.2 0: Failed or not executed 1: Normally completed</td> <td>b5</td> <td>Read completion status of alarm data No.6 0: Failed or not executed 1: Normally completed</td> </tr> <tr> <td>b2</td> <td>Read completion status of alarm data No.3 0: Failed or not executed 1: Normally completed</td> <td>b6</td> <td>Read completion status of alarm data No.7 0: Failed or not executed 1: Normally completed</td> </tr> <tr> <td>b3</td> <td>Read completion status of alarm data No.4 0: Failed or not executed 1: Normally completed</td> <td>b7</td> <td>Read completion status of alarm data No.8 0: Failed or not executed 1: Normally completed</td> </tr> </tbody> </table>	b15	to	b8	b7	to	b0	0					See below.	Bit	Description	Bit	Description	b0	Read completion status of alarm data No.1 0: Failed or not executed 1: Normally completed	b4	Read completion status of alarm data No.5 0: Failed or not executed 1: Normally completed	b1	Read completion status of alarm data No.2 0: Failed or not executed 1: Normally completed	b5	Read completion status of alarm data No.6 0: Failed or not executed 1: Normally completed	b2	Read completion status of alarm data No.3 0: Failed or not executed 1: Normally completed	b6	Read completion status of alarm data No.7 0: Failed or not executed 1: Normally completed	b3	Read completion status of alarm data No.4 0: Failed or not executed 1: Normally completed	b7	Read completion status of alarm data No.8 0: Failed or not executed 1: Normally completed
b15	to	b8	b7	to	b0																												
0					See below.																												
Bit	Description	Bit	Description																														
b0	Read completion status of alarm data No.1 0: Failed or not executed 1: Normally completed	b4	Read completion status of alarm data No.5 0: Failed or not executed 1: Normally completed																														
b1	Read completion status of alarm data No.2 0: Failed or not executed 1: Normally completed	b5	Read completion status of alarm data No.6 0: Failed or not executed 1: Normally completed																														
b2	Read completion status of alarm data No.3 0: Failed or not executed 1: Normally completed	b6	Read completion status of alarm data No.7 0: Failed or not executed 1: Normally completed																														
b3	Read completion status of alarm data No.4 0: Failed or not executed 1: Normally completed	b7	Read completion status of alarm data No.8 0: Failed or not executed 1: Normally completed																														

Tab. 7-40: Response format (when normally completed) (1)

Buffer memory address	Result																				
26449 (6751H)	The length of the alarm data is stored. (Unit: byte) Stored value: 1 to 64																				
26450 (6752H)	Alarm data No.1 The alarm type is stored. <table border="1" style="margin-left: 20px;"> <thead> <tr> <th>Stored value</th> <th>Alarm type</th> </tr> </thead> <tbody> <tr> <td>A510H</td> <td>Diagnosis alarm</td> </tr> <tr> <td>A511H</td> <td>Process alarm</td> </tr> <tr> <td>A512H</td> <td>Pull alarm</td> </tr> <tr> <td>A513H</td> <td>Plug alarm</td> </tr> <tr> <td>A514H</td> <td>Status alarm</td> </tr> <tr> <td>A515H</td> <td>Update alarm</td> </tr> <tr> <td>A516H</td> <td>Manufacturer specific alarm</td> </tr> </tbody> </table>	Stored value	Alarm type	A510H	Diagnosis alarm	A511H	Process alarm	A512H	Pull alarm	A513H	Plug alarm	A514H	Status alarm	A515H	Update alarm	A516H	Manufacturer specific alarm				
Stored value	Alarm type																				
A510H	Diagnosis alarm																				
A511H	Process alarm																				
A512H	Pull alarm																				
A513H	Plug alarm																				
A514H	Status alarm																				
A515H	Update alarm																				
A516H	Manufacturer specific alarm																				
26451 (6753H)	The slot No. is stored. Stored value: 0 to 254																				
26452 (6754H)	Alarm data No.1 The alarm status and sequence No. are stored. <table border="1" style="margin-left: 20px;"> <thead> <tr> <th>b15</th> <th>to</th> <th>b8 b7</th> <th>to</th> <th>b3 b2</th> <th>b1 b0</th> </tr> </thead> <tbody> <tr> <td>0</td> <td></td> <td>③</td> <td></td> <td>②</td> <td>①</td> </tr> </tbody> </table> <p>① Alarm details category is stored. 00 : No additional information 01 : Error detected, and alarm notified from the corresponding slot 10 : No error occurred after alarm notification from the corresponding slot 11 : Error occurred after alarm notification from the corresponding slot</p> <p>② Whether individual ACK is required or not is stored. 0 : No ACK return from the user is required. 1 : ACK return from the user is required.</p> <p>③ Sequence No. is stored. Stored value : 0 to 31</p>	b15	to	b8 b7	to	b3 b2	b1 b0	0		③		②	①								
b15	to	b8 b7	to	b3 b2	b1 b0																
0		③		②	①																
26453 (6755H) to 26484 (6774H)	Alarm data No.1 The alarm data are stored. <table border="1" style="margin-left: 20px;"> <thead> <tr> <th></th> <th>b15</th> <th>b8 b7</th> <th>b0</th> </tr> </thead> <tbody> <tr> <td>26453(6755H)</td> <td>Alarm data (2nd byte)</td> <td>Alarm data (1st byte)</td> <td></td> </tr> <tr> <td>26454(6756H)</td> <td>Alarm data (4th byte)</td> <td>Alarm data (3rd byte)</td> <td></td> </tr> <tr> <td>to</td> <td></td> <td></td> <td></td> </tr> <tr> <td>26484(6774H)</td> <td>Alarm data (64th byte)</td> <td>Alarm data (63rd byte)</td> <td></td> </tr> </tbody> </table>		b15	b8 b7	b0	26453(6755H)	Alarm data (2nd byte)	Alarm data (1st byte)		26454(6756H)	Alarm data (4th byte)	Alarm data (3rd byte)		to				26484(6774H)	Alarm data (64th byte)	Alarm data (63rd byte)	
	b15	b8 b7	b0																		
26453(6755H)	Alarm data (2nd byte)	Alarm data (1st byte)																			
26454(6756H)	Alarm data (4th byte)	Alarm data (3rd byte)																			
to																					
26484(6774H)	Alarm data (64th byte)	Alarm data (63rd byte)																			
26485 (6775H) to 26488 (6778H)	Empty area Stored value: 0000H																				
26489 (6779H) to 26528 (67A0H)	Alarm data No.2																				
26529 (67A1H) to 26568 (67C8H)	Alarm data No.3																				
26569 (67C9H) to 26608 (67F0H)	Alarm data No.4																				
26609 (67F1H) to 26648 (6818H)	Alarm data No.5																				
26649 (6819H) to 26688 (6840H)	Alarm data No.6																				
26689 (6841H) to 26728 (6868H)	Alarm data No.7																				
26729 (6869H) to 26768 (6890H)	Alarm data No.8																				

Tab. 7-40: Response format (when normally completed) (2)

● When failed

Buffer memory address	Result																						
26446 (674EH)	An error code is stored. (Refer to section 9.4.4)																						
26447 (674FH)	The FDL address of the DP-Slave from which the alarm was read is stored. Stored value: 0000H to 007DH (0 to 125)																						
26448 (6750H)	<p>The read completion status of the alarm data is stored.</p> <p>b15 to b8 b7 to b0</p> <table border="1" style="margin-left: 20px;"> <tr> <td style="width: 50px; text-align: center;">0</td> <td style="text-align: center;">See below.</td> </tr> </table> <table border="1" style="margin-left: 20px; width: 100%;"> <thead> <tr> <th style="width: 10%;">Bit</th> <th style="width: 45%;">Description</th> <th style="width: 10%;">Bit</th> <th style="width: 35%;">Description</th> </tr> </thead> <tbody> <tr> <td>b0</td> <td>Read completion status of alarm data No.1 0: Failed or not executed 1: Normally completed</td> <td>b4</td> <td>Read completion status of alarm data No.5 0: Failed or not executed 1: Normally completed</td> </tr> <tr> <td>b1</td> <td>Read completion status of alarm data No.2 0: Failed or not executed 1: Normally completed</td> <td>b5</td> <td>Read completion status of alarm data No.6 0: Failed or not executed 1: Normally completed</td> </tr> <tr> <td>b2</td> <td>Read completion status of alarm data No.3 0: Failed or not executed 1: Normally completed</td> <td>b6</td> <td>Read completion status of alarm data No.7 0: Failed or not executed 1: Normally completed</td> </tr> <tr> <td>b3</td> <td>Read completion status of alarm data No.4 0: Failed or not executed 1: Normally completed</td> <td>b7</td> <td>Read completion status of alarm data No.8 0: Failed or not executed 1: Normally completed</td> </tr> </tbody> </table>	0	See below.	Bit	Description	Bit	Description	b0	Read completion status of alarm data No.1 0: Failed or not executed 1: Normally completed	b4	Read completion status of alarm data No.5 0: Failed or not executed 1: Normally completed	b1	Read completion status of alarm data No.2 0: Failed or not executed 1: Normally completed	b5	Read completion status of alarm data No.6 0: Failed or not executed 1: Normally completed	b2	Read completion status of alarm data No.3 0: Failed or not executed 1: Normally completed	b6	Read completion status of alarm data No.7 0: Failed or not executed 1: Normally completed	b3	Read completion status of alarm data No.4 0: Failed or not executed 1: Normally completed	b7	Read completion status of alarm data No.8 0: Failed or not executed 1: Normally completed
0	See below.																						
Bit	Description	Bit	Description																				
b0	Read completion status of alarm data No.1 0: Failed or not executed 1: Normally completed	b4	Read completion status of alarm data No.5 0: Failed or not executed 1: Normally completed																				
b1	Read completion status of alarm data No.2 0: Failed or not executed 1: Normally completed	b5	Read completion status of alarm data No.6 0: Failed or not executed 1: Normally completed																				
b2	Read completion status of alarm data No.3 0: Failed or not executed 1: Normally completed	b6	Read completion status of alarm data No.7 0: Failed or not executed 1: Normally completed																				
b3	Read completion status of alarm data No.4 0: Failed or not executed 1: Normally completed	b7	Read completion status of alarm data No.8 0: Failed or not executed 1: Normally completed																				
26449 (6751H)	<p>Response result</p> <ul style="list-style-type: none"> • When E506H is currently stored in buffer memory address 26446 (674EH) Detailed error code 1 is stored. (Refer to section 9.4.4) • When a value other than E506H is currently stored in buffer memory address 26446 (674EH) Stored value: FFFFH (No detailed error code 1) 																						
26450 (6752H)																							
26451 (6753H)																							
26452 (6754H) to 26484 (6774H)		Empty area Stored value: 0000H																					
26485 (6775H) to 26488 (6778H)		Empty area Stored value: 0000H																					
26489 (6779H) to 26768 (6890H)		Empty area Stored value: 0000H																					

Tab. 7-41: Response format (when failed)

7.5.2 Alarm ACK request

This section explains the request and response formats of the alarm ACK request.

The alarm ACK request is used for returning ACK to the DP-Slave after execution of the alarm read request (without ACK) and deleting alarms in the DP-Slave.

ACK can be returned for each alarm that was read.

Request format

Buffer memory address	Description/Set value																				
26432 (6740H)	Set a request code. Set value: 1501H																				
26433 (6741H)	Set the FDL address of the DP-Slave to which ACK is to be returned. Set value: 0000H to 007DH(0 to 125)																				
26434 (6742H)	<p>Set the alarm data No. for which ACK is to be returned.</p> <p>b15 to b8 b7 to b0</p> <table border="1" style="margin-left: 40px;"> <tr> <td style="width: 50px;">00H (Fixed)</td> <td style="width: 50px;">See below.</td> </tr> </table> <table border="1" style="margin-left: 40px;"> <thead> <tr> <th>Bit</th> <th>Description</th> </tr> </thead> <tbody> <tr> <td>b0</td> <td>Execution instruction to alarm data No.1</td> </tr> <tr> <td>b1</td> <td>Execution instruction to alarm data No.2</td> </tr> <tr> <td>b2</td> <td>Execution instruction to alarm data No.3</td> </tr> <tr> <td>b3</td> <td>Execution instruction to alarm data No.4</td> </tr> <tr> <td>b4</td> <td>Execution instruction to alarm data No.5</td> </tr> <tr> <td>b5</td> <td>Execution instruction to alarm data No.6</td> </tr> <tr> <td>b6</td> <td>Execution instruction to alarm data No.7</td> </tr> <tr> <td>b7</td> <td>Execution instruction to alarm data No.8</td> </tr> </tbody> </table>	00H (Fixed)	See below.	Bit	Description	b0	Execution instruction to alarm data No.1	b1	Execution instruction to alarm data No.2	b2	Execution instruction to alarm data No.3	b3	Execution instruction to alarm data No.4	b4	Execution instruction to alarm data No.5	b5	Execution instruction to alarm data No.6	b6	Execution instruction to alarm data No.7	b7	Execution instruction to alarm data No.8
00H (Fixed)	See below.																				
Bit	Description																				
b0	Execution instruction to alarm data No.1																				
b1	Execution instruction to alarm data No.2																				
b2	Execution instruction to alarm data No.3																				
b3	Execution instruction to alarm data No.4																				
b4	Execution instruction to alarm data No.5																				
b5	Execution instruction to alarm data No.6																				
b6	Execution instruction to alarm data No.7																				
b7	Execution instruction to alarm data No.8																				

Tab. 7-42: Request format

Response format

- When normally completed

Buffer memory address	Result																																										
26446 (674EH)	A response code is stored. Stored value: A501H																																										
26447 (674FH)	The FDL address of the DP-Slave that returned ACK is stored. Stored value: 0000H to 007DH (0 to 125)																																										
26448 (6750H)	<p>The alarm data read completion status and the ACK response completion status are stored.</p> <p>b15 to b8 b7 to b0</p> <table border="1" style="margin-left: 40px;"> <tr> <td style="text-align: center;">2</td> <td style="text-align: center;">1</td> </tr> </table> <p>① The read completion status of the alarm data is stored.</p> <table border="1" style="margin-left: 40px;"> <thead> <tr> <th>Bit</th> <th>Description</th> <th>Bit</th> <th>Description</th> </tr> </thead> <tbody> <tr> <td>b0</td> <td>Read completion status of alarm data No.1 0: Failed or not executed 1: Normally completed</td> <td>b4</td> <td>Read completion status of alarm data No.5 0: Failed or not executed 1: Normally completed</td> </tr> <tr> <td>b1</td> <td>Read completion status of alarm data No.2 0: Failed or not executed 1: Normally completed</td> <td>b5</td> <td>Read completion status of alarm data No.6 0: Failed or not executed 1: Normally completed</td> </tr> <tr> <td>b2</td> <td>Read completion status of alarm data No.3 0: Failed or not executed 1: Normally completed</td> <td>b6</td> <td>Read completion status of alarm data No.7 0: Failed or not executed 1: Normally completed</td> </tr> <tr> <td>b3</td> <td>Read completion status of alarm data No.4 0: Failed or not executed 1: Normally completed</td> <td>b7</td> <td>Read completion status of alarm data No.8 0: Failed or not executed 1: Normally completed</td> </tr> </tbody> </table> <p>② The ACK response completion status is stored.</p> <table border="1" style="margin-left: 40px;"> <thead> <tr> <th>Bit</th> <th>Description</th> <th>Bit</th> <th>Description</th> </tr> </thead> <tbody> <tr> <td>b8</td> <td>Completion status of response to alarm data No.1 0: Failed or not executed 1: Normally completed</td> <td>b12</td> <td>Completion status of response to alarm data No.5 0: Failed or not executed 1: Normally completed</td> </tr> <tr> <td>b9</td> <td>Completion status of response to alarm data No.2 0: Failed or not executed 1: Normally completed</td> <td>b13</td> <td>Completion status of response to alarm data No.6 0: Failed or not executed 1: Normally completed</td> </tr> <tr> <td>b10</td> <td>Completion status of response to alarm data No.3 0: Failed or not executed 1: Normally completed</td> <td>b14</td> <td>Completion status of response to alarm data No.7 0: Failed or not executed 1: Normally completed</td> </tr> <tr> <td>b11</td> <td>Completion status of response to alarm data No.4 0: Failed or not executed 1: Normally completed</td> <td>b15</td> <td>Completion status of response to alarm data No.8 0: Failed or not executed 1: Normally completed</td> </tr> </tbody> </table>	2	1	Bit	Description	Bit	Description	b0	Read completion status of alarm data No.1 0: Failed or not executed 1: Normally completed	b4	Read completion status of alarm data No.5 0: Failed or not executed 1: Normally completed	b1	Read completion status of alarm data No.2 0: Failed or not executed 1: Normally completed	b5	Read completion status of alarm data No.6 0: Failed or not executed 1: Normally completed	b2	Read completion status of alarm data No.3 0: Failed or not executed 1: Normally completed	b6	Read completion status of alarm data No.7 0: Failed or not executed 1: Normally completed	b3	Read completion status of alarm data No.4 0: Failed or not executed 1: Normally completed	b7	Read completion status of alarm data No.8 0: Failed or not executed 1: Normally completed	Bit	Description	Bit	Description	b8	Completion status of response to alarm data No.1 0: Failed or not executed 1: Normally completed	b12	Completion status of response to alarm data No.5 0: Failed or not executed 1: Normally completed	b9	Completion status of response to alarm data No.2 0: Failed or not executed 1: Normally completed	b13	Completion status of response to alarm data No.6 0: Failed or not executed 1: Normally completed	b10	Completion status of response to alarm data No.3 0: Failed or not executed 1: Normally completed	b14	Completion status of response to alarm data No.7 0: Failed or not executed 1: Normally completed	b11	Completion status of response to alarm data No.4 0: Failed or not executed 1: Normally completed	b15	Completion status of response to alarm data No.8 0: Failed or not executed 1: Normally completed
2	1																																										
Bit	Description	Bit	Description																																								
b0	Read completion status of alarm data No.1 0: Failed or not executed 1: Normally completed	b4	Read completion status of alarm data No.5 0: Failed or not executed 1: Normally completed																																								
b1	Read completion status of alarm data No.2 0: Failed or not executed 1: Normally completed	b5	Read completion status of alarm data No.6 0: Failed or not executed 1: Normally completed																																								
b2	Read completion status of alarm data No.3 0: Failed or not executed 1: Normally completed	b6	Read completion status of alarm data No.7 0: Failed or not executed 1: Normally completed																																								
b3	Read completion status of alarm data No.4 0: Failed or not executed 1: Normally completed	b7	Read completion status of alarm data No.8 0: Failed or not executed 1: Normally completed																																								
Bit	Description	Bit	Description																																								
b8	Completion status of response to alarm data No.1 0: Failed or not executed 1: Normally completed	b12	Completion status of response to alarm data No.5 0: Failed or not executed 1: Normally completed																																								
b9	Completion status of response to alarm data No.2 0: Failed or not executed 1: Normally completed	b13	Completion status of response to alarm data No.6 0: Failed or not executed 1: Normally completed																																								
b10	Completion status of response to alarm data No.3 0: Failed or not executed 1: Normally completed	b14	Completion status of response to alarm data No.7 0: Failed or not executed 1: Normally completed																																								
b11	Completion status of response to alarm data No.4 0: Failed or not executed 1: Normally completed	b15	Completion status of response to alarm data No.8 0: Failed or not executed 1: Normally completed																																								

Tab. 7-43: Response format (when normally completed) (1)

Buffer memory address	Result																	
26449 (6751H) to 26484 (6774H)	Alarm data No.1	The alarm data that was read by the alarm read request (without ACK) is stored. (Refer to page 7-33)																
26485 (6775H)		A response code is stored. ① Stored value: A501H																
26486 (6776H)		The alarm type is stored. ① <table border="1" style="margin-left: 20px;"> <thead> <tr> <th>Stored value</th> <th>Alarm type</th> </tr> </thead> <tbody> <tr> <td>A510H</td> <td>Diagnosis alarm type</td> </tr> <tr> <td>A511H</td> <td>Process alarm</td> </tr> <tr> <td>A512H</td> <td>Pull alarm</td> </tr> <tr> <td>A513H</td> <td>Plug alarm</td> </tr> <tr> <td>A514H</td> <td>Status alarm</td> </tr> <tr> <td>A515H</td> <td>Update alarm</td> </tr> <tr> <td>A516H</td> <td>Manufacturer specific alarm</td> </tr> </tbody> </table>	Stored value	Alarm type	A510H	Diagnosis alarm type	A511H	Process alarm	A512H	Pull alarm	A513H	Plug alarm	A514H	Status alarm	A515H	Update alarm	A516H	Manufacturer specific alarm
Stored value		Alarm type																
A510H	Diagnosis alarm type																	
A511H	Process alarm																	
A512H	Pull alarm																	
A513H	Plug alarm																	
A514H	Status alarm																	
A515H	Update alarm																	
A516H	Manufacturer specific alarm																	
26487 (6777H)	The alarm status and sequence No. are stored. ① <table border="1" style="margin-left: 20px;"> <tr> <td>b15</td> <td>to</td> <td>b8 b7</td> <td>to</td> <td>b3 b2</td> <td>b1 b0</td> </tr> <tr> <td>0</td> <td></td> <td>③</td> <td></td> <td>②</td> <td>①</td> </tr> </table> <p>① Alarm details category is stored. 00 : No additional information 01 : Error detected, and alarm notified from the corresponding slot 10 : No error occurred after alarm notification from the corresponding slot 11 : Error occurred after alarm notification from the corresponding slot</p> <p>② Whether individual ACK is required or not is stored. 0 : No ACK return from the user is required. 1 : ACK return from the user is required.</p> <p>③ Sequence No. is stored. Stored value : 0 to 31</p>	b15	to	b8 b7	to	b3 b2	b1 b0	0		③		②	①					
b15	to	b8 b7	to	b3 b2	b1 b0													
0		③		②	①													
26488 (6778H)	The slot No. is stored. ① Stored value: 0 to 254																	
26489 (6779H) to 26528 (67A0H)	Alarm data No.2	(Same as alarm data No.1)																
26529 (67A1H) to 26568 (67C8H)	Alarm data No.3																	
26569 (67C9H) to 26608 (67F0H)	Alarm data No.4																	
26609 (67F1H) to 26648 (6818H)	Alarm data No.5																	
26649 (6819H) to 26688 (6840H)	Alarm data No.6																	
26689 (6841H) to 26728 (6868H)	Alarm data No.7																	
26729 (6869H) to 26768 (6890H)	Alarm data No.8																	

Tab. 7-43: Response format (when normally completed) (2)

① Data are stored only when the ACK response completion status is "Normally completed" (the corresponding bit in buffer memory address 26448 (6750H) is ON).

● When failed

Buffer memory address	Result																																										
26446 (674EH)	An error code is stored. (Refer to section 9.4.4)																																										
26447 (674FH)	The FDL address of the DP-Slave that returned ACK is stored. Stored value: 0000H to 007DH(0 to 125)																																										
26448 (6750H)	<p>The alarm data read completion status and the ACK response completion status are stored.</p> <p>b15 to b8 b7 to b0</p> <table border="1" style="margin-left: 40px;"> <tr> <td style="text-align: center;">2</td> <td style="text-align: center;">1</td> </tr> </table> <p>① The read completion status of the alarm data is stored.</p> <table border="1" style="margin-left: 40px;"> <thead> <tr> <th>Bit</th> <th>Description</th> <th>Bit</th> <th>Description</th> </tr> </thead> <tbody> <tr> <td>b0</td> <td>Read completion status of alarm data No.1 0: Failed or not executed 1: Normally completed</td> <td>b4</td> <td>Read completion status of alarm data No.5 0: Failed or not executed 1: Normally completed</td> </tr> <tr> <td>b1</td> <td>Read completion status of alarm data No.2 0: Failed or not executed 1: Normally completed</td> <td>b5</td> <td>Read completion status of alarm data No.6 0: Failed or not executed 1: Normally completed</td> </tr> <tr> <td>b2</td> <td>Read completion status of alarm data No.3 0: Failed or not executed 1: Normally completed</td> <td>b6</td> <td>Read completion status of alarm data No.7 0: Failed or not executed 1: Normally completed</td> </tr> <tr> <td>b3</td> <td>Read completion status of alarm data No.4 0: Failed or not executed 1: Normally completed</td> <td>b7</td> <td>Read completion status of alarm data No.8 0: Failed or not executed 1: Normally completed</td> </tr> </tbody> </table> <p>② The ACK response completion status is stored.</p> <table border="1" style="margin-left: 40px;"> <thead> <tr> <th>Bit</th> <th>Description</th> <th>Bit</th> <th>Description</th> </tr> </thead> <tbody> <tr> <td>b8</td> <td>Completion status of response to alarm data No.1 0: Failed or not executed 1: Normally completed</td> <td>b12</td> <td>Completion status of response to alarm data No.5 0: Failed or not executed 1: Normally completed</td> </tr> <tr> <td>b9</td> <td>Completion status of response to alarm data No.2 0: Failed or not executed 1: Normally completed</td> <td>b13</td> <td>Completion status of response to alarm data No.6 0: Failed or not executed 1: Normally completed</td> </tr> <tr> <td>b10</td> <td>Completion status of response to alarm data No.3 0: Failed or not executed 1: Normally completed</td> <td>b14</td> <td>Completion status of response to alarm data No.7 0: Failed or not executed 1: Normally completed</td> </tr> <tr> <td>b11</td> <td>Completion status of response to alarm data No.4 0: Failed or not executed 1: Normally completed</td> <td>b15</td> <td>Completion status of response to alarm data No.8 0: Failed or not executed 1: Normally completed</td> </tr> </tbody> </table>	2	1	Bit	Description	Bit	Description	b0	Read completion status of alarm data No.1 0: Failed or not executed 1: Normally completed	b4	Read completion status of alarm data No.5 0: Failed or not executed 1: Normally completed	b1	Read completion status of alarm data No.2 0: Failed or not executed 1: Normally completed	b5	Read completion status of alarm data No.6 0: Failed or not executed 1: Normally completed	b2	Read completion status of alarm data No.3 0: Failed or not executed 1: Normally completed	b6	Read completion status of alarm data No.7 0: Failed or not executed 1: Normally completed	b3	Read completion status of alarm data No.4 0: Failed or not executed 1: Normally completed	b7	Read completion status of alarm data No.8 0: Failed or not executed 1: Normally completed	Bit	Description	Bit	Description	b8	Completion status of response to alarm data No.1 0: Failed or not executed 1: Normally completed	b12	Completion status of response to alarm data No.5 0: Failed or not executed 1: Normally completed	b9	Completion status of response to alarm data No.2 0: Failed or not executed 1: Normally completed	b13	Completion status of response to alarm data No.6 0: Failed or not executed 1: Normally completed	b10	Completion status of response to alarm data No.3 0: Failed or not executed 1: Normally completed	b14	Completion status of response to alarm data No.7 0: Failed or not executed 1: Normally completed	b11	Completion status of response to alarm data No.4 0: Failed or not executed 1: Normally completed	b15	Completion status of response to alarm data No.8 0: Failed or not executed 1: Normally completed
2	1																																										
Bit	Description	Bit	Description																																								
b0	Read completion status of alarm data No.1 0: Failed or not executed 1: Normally completed	b4	Read completion status of alarm data No.5 0: Failed or not executed 1: Normally completed																																								
b1	Read completion status of alarm data No.2 0: Failed or not executed 1: Normally completed	b5	Read completion status of alarm data No.6 0: Failed or not executed 1: Normally completed																																								
b2	Read completion status of alarm data No.3 0: Failed or not executed 1: Normally completed	b6	Read completion status of alarm data No.7 0: Failed or not executed 1: Normally completed																																								
b3	Read completion status of alarm data No.4 0: Failed or not executed 1: Normally completed	b7	Read completion status of alarm data No.8 0: Failed or not executed 1: Normally completed																																								
Bit	Description	Bit	Description																																								
b8	Completion status of response to alarm data No.1 0: Failed or not executed 1: Normally completed	b12	Completion status of response to alarm data No.5 0: Failed or not executed 1: Normally completed																																								
b9	Completion status of response to alarm data No.2 0: Failed or not executed 1: Normally completed	b13	Completion status of response to alarm data No.6 0: Failed or not executed 1: Normally completed																																								
b10	Completion status of response to alarm data No.3 0: Failed or not executed 1: Normally completed	b14	Completion status of response to alarm data No.7 0: Failed or not executed 1: Normally completed																																								
b11	Completion status of response to alarm data No.4 0: Failed or not executed 1: Normally completed	b15	Completion status of response to alarm data No.8 0: Failed or not executed 1: Normally completed																																								

Tab. 7-44: Response format (when failed) (1)

Buffer memory address	Result		
26449 (6751H) to 26484 (6774H)	Alarm data No.1	The alarm data that was read by the alarm read request (without ACK) is stored. (Refer to page 7-33)	
26485 (6775H)		An error code is stored. ① (Refer to section 9.4.4)	
26486 (6776H)		<ul style="list-style-type: none"> When E508H is currently stored in buffer memory address 26485 (6775H) Detailed error code 1 is stored. ① (Refer to section 9.4.4) When a value other than E508H is currently stored in buffer memory address 26485 (6775H) Stored value: FFFFH (No detailed error code 1) ① 	
26487 (6777H)		<ul style="list-style-type: none"> When E508H is currently stored in buffer memory address 26485 (6775H) Detailed error code 2 is stored. ① (Refer to section 9.4.4) When a value other than E508H is currently stored in buffer memory address 26485 (6775H) Stored value: FFFFH (No detailed error code 2) ① 	
26488 (6778H)		<ul style="list-style-type: none"> When E508H is currently stored in buffer memory address 26485 (6775H) Detailed error code 3 is stored. ① (Refer to section 9.4.4) When a value other than E508H is currently stored in buffer memory address 26485 (6775H) Stored value: FFFFH (No detailed error code 3) ① 	
26489 (6779H) to 26528 (67A0H)		Alarm data No.2	(Same as alarm data No.1)
26529 (67A1H) to 26568 (67C8H)		Alarm data No.3	
26569 (67C9H) to 26608 (67F0H)		Alarm data No.4	
26609 (67F1H) to 26648 (6818H)	Alarm data No.5		
26649 (6819H) to 26688 (6840H)	Alarm data No.6		
26689 (6841H) to 26728 (6868H)	Alarm data No.7		
26729 (6869H) to 26768 (6890H)	Alarm data No.8		

Tab. 7-44: Response format (when failed) (2)

① Data are stored only when the ACK response completion status is "Failed" (the corresponding bit in buffer memory address 26448 (6750H) is OFF).

7.5.3 Alarm read request (with ACK)

This section explains the request and response formats of the alarm read request (with ACK).

Request format

Buffer memory address	Description/Set value
26432 (6740H)	Set a request code. Set value: 1502H
26433 (6741H)	Set the FDL address of the DP-Slave whose alarm is to be read. Set value: 0000H to 007DH (0 to 125)
26434 (6742H)	Empty area (Write 0000H.) Set value: Fixed to 0000H

Tab. 7-45: Request format

Response format

- When normally completed

Buffer memory address	Result																																										
26446 (674EH)	A response code is stored. Stored value: A502H																																										
26447 (674FH)	The FDL address of the DP-Slave whose alarm was read is stored. Stored value: 0000H to 007DH (0 to 125)																																										
26448 (6750H)	<p>The alarm data read completion status and the ACK response completion status are stored.</p> <p>b15 to b8 b7 to b0</p> <table border="1" style="margin-left: 40px;"> <tr> <td style="width: 40px; text-align: center;">2</td> <td style="width: 40px; text-align: center;">1</td> </tr> </table> <p>① The read completion status of the alarm data is stored.</p> <table border="1" style="margin-left: 40px;"> <thead> <tr> <th>Bit</th> <th>Description</th> <th>Bit</th> <th>Description</th> </tr> </thead> <tbody> <tr> <td>b0</td> <td>Read completion status of alarm data No.1 0: Failed or not executed 1: Normally completed</td> <td>b4</td> <td>Read completion status of alarm data No.5 0: Failed or not executed 1: Normally completed</td> </tr> <tr> <td>b1</td> <td>Read completion status of alarm data No.2 0: Failed or not executed 1: Normally completed</td> <td>b5</td> <td>Read completion status of alarm data No.6 0: Failed or not executed 1: Normally completed</td> </tr> <tr> <td>b2</td> <td>Read completion status of alarm data No.3 0: Failed or not executed 1: Normally completed</td> <td>b6</td> <td>Read completion status of alarm data No.7 0: Failed or not executed 1: Normally completed</td> </tr> <tr> <td>b3</td> <td>Read completion status of alarm data No.4 0: Failed or not executed 1: Normally completed</td> <td>b7</td> <td>Read completion status of alarm data No.8 0: Failed or not executed 1: Normally completed</td> </tr> </tbody> </table> <p>② The ACK response completion status is stored.</p> <table border="1" style="margin-left: 40px;"> <thead> <tr> <th>Bit</th> <th>Description</th> <th>Bit</th> <th>Description</th> </tr> </thead> <tbody> <tr> <td>b8</td> <td>Completion status of response to alarm data No.1 0: Failed or not executed 1: Normally completed</td> <td>b12</td> <td>Completion status of response to alarm data No.5 0: Failed or not executed 1: Normally completed</td> </tr> <tr> <td>b9</td> <td>Completion status of response to alarm data No.2 0: Failed or not executed 1: Normally completed</td> <td>b13</td> <td>Completion status of response to alarm data No.6 0: Failed or not executed 1: Normally completed</td> </tr> <tr> <td>b10</td> <td>Completion status of response to alarm data No.3 0: Failed or not executed 1: Normally completed</td> <td>b14</td> <td>Completion status of response to alarm data No.7 0: Failed or not executed 1: Normally completed</td> </tr> <tr> <td>b11</td> <td>Completion status of response to alarm data No.4 0: Failed or not executed 1: Normally completed</td> <td>b15</td> <td>Completion status of response to alarm data No.8 0: Failed or not executed 1: Normally completed</td> </tr> </tbody> </table>	2	1	Bit	Description	Bit	Description	b0	Read completion status of alarm data No.1 0: Failed or not executed 1: Normally completed	b4	Read completion status of alarm data No.5 0: Failed or not executed 1: Normally completed	b1	Read completion status of alarm data No.2 0: Failed or not executed 1: Normally completed	b5	Read completion status of alarm data No.6 0: Failed or not executed 1: Normally completed	b2	Read completion status of alarm data No.3 0: Failed or not executed 1: Normally completed	b6	Read completion status of alarm data No.7 0: Failed or not executed 1: Normally completed	b3	Read completion status of alarm data No.4 0: Failed or not executed 1: Normally completed	b7	Read completion status of alarm data No.8 0: Failed or not executed 1: Normally completed	Bit	Description	Bit	Description	b8	Completion status of response to alarm data No.1 0: Failed or not executed 1: Normally completed	b12	Completion status of response to alarm data No.5 0: Failed or not executed 1: Normally completed	b9	Completion status of response to alarm data No.2 0: Failed or not executed 1: Normally completed	b13	Completion status of response to alarm data No.6 0: Failed or not executed 1: Normally completed	b10	Completion status of response to alarm data No.3 0: Failed or not executed 1: Normally completed	b14	Completion status of response to alarm data No.7 0: Failed or not executed 1: Normally completed	b11	Completion status of response to alarm data No.4 0: Failed or not executed 1: Normally completed	b15	Completion status of response to alarm data No.8 0: Failed or not executed 1: Normally completed
2	1																																										
Bit	Description	Bit	Description																																								
b0	Read completion status of alarm data No.1 0: Failed or not executed 1: Normally completed	b4	Read completion status of alarm data No.5 0: Failed or not executed 1: Normally completed																																								
b1	Read completion status of alarm data No.2 0: Failed or not executed 1: Normally completed	b5	Read completion status of alarm data No.6 0: Failed or not executed 1: Normally completed																																								
b2	Read completion status of alarm data No.3 0: Failed or not executed 1: Normally completed	b6	Read completion status of alarm data No.7 0: Failed or not executed 1: Normally completed																																								
b3	Read completion status of alarm data No.4 0: Failed or not executed 1: Normally completed	b7	Read completion status of alarm data No.8 0: Failed or not executed 1: Normally completed																																								
Bit	Description	Bit	Description																																								
b8	Completion status of response to alarm data No.1 0: Failed or not executed 1: Normally completed	b12	Completion status of response to alarm data No.5 0: Failed or not executed 1: Normally completed																																								
b9	Completion status of response to alarm data No.2 0: Failed or not executed 1: Normally completed	b13	Completion status of response to alarm data No.6 0: Failed or not executed 1: Normally completed																																								
b10	Completion status of response to alarm data No.3 0: Failed or not executed 1: Normally completed	b14	Completion status of response to alarm data No.7 0: Failed or not executed 1: Normally completed																																								
b11	Completion status of response to alarm data No.4 0: Failed or not executed 1: Normally completed	b15	Completion status of response to alarm data No.8 0: Failed or not executed 1: Normally completed																																								

Tab. 7-46: Response format (when normally completed) (1)

Buffer memory address	Result																				
26449 (6751H)	The length of the alarm data is stored. (Unit: byte) Stored value: 1 to 64																				
26450 (6752H)	The alarm type is stored. <table border="1"> <thead> <tr> <th>Stored value</th> <th>Alarm type</th> </tr> </thead> <tbody> <tr> <td>A510H</td> <td>Diagnosis alarm</td> </tr> <tr> <td>A511H</td> <td>Process alarm</td> </tr> <tr> <td>A512H</td> <td>Pull alarm</td> </tr> <tr> <td>A513H</td> <td>Plug alarm</td> </tr> <tr> <td>A514H</td> <td>Status alarm</td> </tr> <tr> <td>A515H</td> <td>Update alarm</td> </tr> <tr> <td>A516H</td> <td>Manufacturer specific alarm</td> </tr> </tbody> </table>	Stored value	Alarm type	A510H	Diagnosis alarm	A511H	Process alarm	A512H	Pull alarm	A513H	Plug alarm	A514H	Status alarm	A515H	Update alarm	A516H	Manufacturer specific alarm				
Stored value	Alarm type																				
A510H	Diagnosis alarm																				
A511H	Process alarm																				
A512H	Pull alarm																				
A513H	Plug alarm																				
A514H	Status alarm																				
A515H	Update alarm																				
A516H	Manufacturer specific alarm																				
26451 (6753H)	The slot No. is stored. Stored value: 0 to 254																				
26452 (6754H)	The alarm status and sequence No. are stored. <table border="1"> <thead> <tr> <th>b15</th> <th>to</th> <th>b8 b7</th> <th>to</th> <th>b3 b2 b1 b0</th> </tr> </thead> <tbody> <tr> <td>0</td> <td></td> <td>③</td> <td></td> <td>② ①</td> </tr> </tbody> </table> <p>① Alarm details category is stored. 00 : No additional information 01 : Error detected, and alarm notified from the corresponding slot 10 : No error occurred after alarm notification from the corresponding slot 11 : Error occurred after alarm notification from the corresponding slot</p> <p>② Whether individual ACK is required or not is stored. 0 : No ACK return from the user is required. 1 : ACK return from the user is required.</p> <p>③ Sequence No. is stored. Stored value : 0 to 31</p>	b15	to	b8 b7	to	b3 b2 b1 b0	0		③		② ①										
b15	to	b8 b7	to	b3 b2 b1 b0																	
0		③		② ①																	
26453 (6755H) to 26484 (6774H)	The alarm data are stored. <table border="1"> <thead> <tr> <th></th> <th>b15</th> <th>b8 b7</th> <th>b0</th> </tr> </thead> <tbody> <tr> <td>26453 (6755H)</td> <td>Alarm data (2nd byte)</td> <td>Alarm data (1st byte)</td> <td></td> </tr> <tr> <td>26454 (6756H)</td> <td>Alarm data (4th byte)</td> <td>Alarm data (3rd byte)</td> <td></td> </tr> <tr> <td>to</td> <td></td> <td></td> <td></td> </tr> <tr> <td>26484 (6774H)</td> <td>Alarm data (64th byte)</td> <td>Alarm data (63rd byte)</td> <td></td> </tr> </tbody> </table>		b15	b8 b7	b0	26453 (6755H)	Alarm data (2nd byte)	Alarm data (1st byte)		26454 (6756H)	Alarm data (4th byte)	Alarm data (3rd byte)		to				26484 (6774H)	Alarm data (64th byte)	Alarm data (63rd byte)	
	b15	b8 b7	b0																		
26453 (6755H)	Alarm data (2nd byte)	Alarm data (1st byte)																			
26454 (6756H)	Alarm data (4th byte)	Alarm data (3rd byte)																			
to																					
26484 (6774H)	Alarm data (64th byte)	Alarm data (63rd byte)																			
26485(6775H)	A response code is stored. ① Stored value: A501H																				
26486 (6776H)	The alarm type is stored. ① <table border="1"> <thead> <tr> <th>Stored value</th> <th>Alarm type</th> </tr> </thead> <tbody> <tr> <td>A510H</td> <td>Diagnosis alarm</td> </tr> <tr> <td>A511H</td> <td>Process alarm</td> </tr> <tr> <td>A512H</td> <td>Pull alarm</td> </tr> <tr> <td>A513H</td> <td>Plug alarm</td> </tr> <tr> <td>A514H</td> <td>Status alarm</td> </tr> <tr> <td>A515H</td> <td>Update alarm</td> </tr> <tr> <td>A516H</td> <td>Manufacturer specific alarm</td> </tr> </tbody> </table>	Stored value	Alarm type	A510H	Diagnosis alarm	A511H	Process alarm	A512H	Pull alarm	A513H	Plug alarm	A514H	Status alarm	A515H	Update alarm	A516H	Manufacturer specific alarm				
Stored value	Alarm type																				
A510H	Diagnosis alarm																				
A511H	Process alarm																				
A512H	Pull alarm																				
A513H	Plug alarm																				
A514H	Status alarm																				
A515H	Update alarm																				
A516H	Manufacturer specific alarm																				

Tab. 7-46: Response format (when normally completed) (2)

Buffer memory address	Result					
26487 (6777H)	Alarm data No.1	The alarm status and sequence No. are stored. ^① b15 to b8 b7 to b3 b2 b1 b0 <table border="1" style="margin-left: 40px;"> <tr> <td style="width: 40px; text-align: center;">0</td> <td style="width: 40px; text-align: center;">3</td> <td style="width: 40px; text-align: center;">2</td> <td style="width: 40px; text-align: center;">1</td> </tr> </table> <ul style="list-style-type: none"> ① Alarm details category is stored. 00 : No additional information 01 : Error detected, and alarm notified from the corresponding slot 10 : No error occurred after alarm notification from the corresponding slot 11 : Error occurred after alarm notification from the corresponding slot ② Whether individual ACK is required or not is stored. 0 : No ACK return from the user is required. 1 : ACK return from the user is required. ③ Sequence No. is stored. Stored value : 0 to 31 	0	3	2	1
0		3	2	1		
26488 (6778H)	The slot No. is stored. ^① Stored value: 0 to 254					
26489 (6779H) to 26528 (67A0H)	Alarm data No.2	(Same as alarm data No.1)				
26529 (67A1H) to 26568 (67C8H)	Alarm data No.3					
26569 (67C9H) to 26608 (67F0H)	Alarm data No.4					
26609 (67F1H) to 26648 (6818H)	Alarm data No.5					
26649 (6819H) to 26688 (6840H)	Alarm data No.6					
26689 (6841H) to 26728 (6868H)	Alarm data No.7					
26729 (6869H) to 26768 (6890H)	Alarm data No.8					

Tab. 7-46: Response format (when normally completed) (3)

^① Data are stored only when the ACK response completion status is Normal completion (the corresponding bit in buffer memory address 26448 (6750H) is ON).

● When failed

Buffer memory address	Result																																										
26446 (674EH)	An error code is stored. (Refer to section 9.4.4)																																										
26447 (674FH)	The FDL address of the DP-Slave whose alarm was read is stored. Stored value: 0000H to 007DH(0 to 125)																																										
26448 (6750H)	<p>The alarm data read completion status and the ACK response completion status are stored.</p> <p>b15 to b8 b7 to b0</p> <table border="1" style="margin-left: 40px;"> <tr> <td style="text-align: center;">2</td> <td style="text-align: center;">1</td> </tr> </table> <p>① The read completion status of the alarm data is stored.</p> <table border="1" style="margin-left: 40px;"> <thead> <tr> <th>Bit</th> <th>Description</th> <th>Bit</th> <th>Description</th> </tr> </thead> <tbody> <tr> <td>b0</td> <td>Read completion status of alarm data No.1 0: Failed or not executed 1: Normally completed</td> <td>b4</td> <td>Read completion status of alarm data No.5 0: Failed or not executed 1: Normally completed</td> </tr> <tr> <td>b1</td> <td>Read completion status of alarm data No.2 0: Failed or not executed 1: Normally completed</td> <td>b5</td> <td>Read completion status of alarm data No.6 0: Failed or not executed 1: Normally completed</td> </tr> <tr> <td>b2</td> <td>Read completion status of alarm data No.3 0: Failed or not executed 1: Normally completed</td> <td>b6</td> <td>Read completion status of alarm data No.7 0: Failed or not executed 1: Normally completed</td> </tr> <tr> <td>b3</td> <td>Read completion status of alarm data No.4 0: Failed or not executed 1: Normally completed</td> <td>b7</td> <td>Read completion status of alarm data No.8 0: Failed or not executed 1: Normally completed</td> </tr> </tbody> </table> <p>② The ACK response completion status is stored.</p> <table border="1" style="margin-left: 40px;"> <thead> <tr> <th>Bit</th> <th>Description</th> <th>Bit</th> <th>Description</th> </tr> </thead> <tbody> <tr> <td>b8</td> <td>Completion status of response to alarm data No.1 0: Failed or not executed 1: Normally completed</td> <td>b12</td> <td>Completion status of response to alarm data No.5 0: Failed or not executed 1: Normally completed</td> </tr> <tr> <td>b9</td> <td>Completion status of response to alarm data No.2 0: Failed or not executed 1: Normally completed</td> <td>b13</td> <td>Completion status of response to alarm data No.6 0: Failed or not executed 1: Normally completed</td> </tr> <tr> <td>b10</td> <td>Completion status of response to alarm data No.3 0: Failed or not executed 1: Normally completed</td> <td>b14</td> <td>Completion status of response to alarm data No.7 0: Failed or not executed 1: Normally completed</td> </tr> <tr> <td>b11</td> <td>Completion status of response to alarm data No.4 0: Failed or not executed 1: Normally completed</td> <td>b15</td> <td>Completion status of response to alarm data No.8 0: Failed or not executed 1: Normally completed</td> </tr> </tbody> </table>	2	1	Bit	Description	Bit	Description	b0	Read completion status of alarm data No.1 0: Failed or not executed 1: Normally completed	b4	Read completion status of alarm data No.5 0: Failed or not executed 1: Normally completed	b1	Read completion status of alarm data No.2 0: Failed or not executed 1: Normally completed	b5	Read completion status of alarm data No.6 0: Failed or not executed 1: Normally completed	b2	Read completion status of alarm data No.3 0: Failed or not executed 1: Normally completed	b6	Read completion status of alarm data No.7 0: Failed or not executed 1: Normally completed	b3	Read completion status of alarm data No.4 0: Failed or not executed 1: Normally completed	b7	Read completion status of alarm data No.8 0: Failed or not executed 1: Normally completed	Bit	Description	Bit	Description	b8	Completion status of response to alarm data No.1 0: Failed or not executed 1: Normally completed	b12	Completion status of response to alarm data No.5 0: Failed or not executed 1: Normally completed	b9	Completion status of response to alarm data No.2 0: Failed or not executed 1: Normally completed	b13	Completion status of response to alarm data No.6 0: Failed or not executed 1: Normally completed	b10	Completion status of response to alarm data No.3 0: Failed or not executed 1: Normally completed	b14	Completion status of response to alarm data No.7 0: Failed or not executed 1: Normally completed	b11	Completion status of response to alarm data No.4 0: Failed or not executed 1: Normally completed	b15	Completion status of response to alarm data No.8 0: Failed or not executed 1: Normally completed
2	1																																										
Bit	Description	Bit	Description																																								
b0	Read completion status of alarm data No.1 0: Failed or not executed 1: Normally completed	b4	Read completion status of alarm data No.5 0: Failed or not executed 1: Normally completed																																								
b1	Read completion status of alarm data No.2 0: Failed or not executed 1: Normally completed	b5	Read completion status of alarm data No.6 0: Failed or not executed 1: Normally completed																																								
b2	Read completion status of alarm data No.3 0: Failed or not executed 1: Normally completed	b6	Read completion status of alarm data No.7 0: Failed or not executed 1: Normally completed																																								
b3	Read completion status of alarm data No.4 0: Failed or not executed 1: Normally completed	b7	Read completion status of alarm data No.8 0: Failed or not executed 1: Normally completed																																								
Bit	Description	Bit	Description																																								
b8	Completion status of response to alarm data No.1 0: Failed or not executed 1: Normally completed	b12	Completion status of response to alarm data No.5 0: Failed or not executed 1: Normally completed																																								
b9	Completion status of response to alarm data No.2 0: Failed or not executed 1: Normally completed	b13	Completion status of response to alarm data No.6 0: Failed or not executed 1: Normally completed																																								
b10	Completion status of response to alarm data No.3 0: Failed or not executed 1: Normally completed	b14	Completion status of response to alarm data No.7 0: Failed or not executed 1: Normally completed																																								
b11	Completion status of response to alarm data No.4 0: Failed or not executed 1: Normally completed	b15	Completion status of response to alarm data No.8 0: Failed or not executed 1: Normally completed																																								

Tab. 7-47: Response format (when failed) (1)

Buffer memory address	Result	
26449 (6751H)	Alarm data No.1	<ul style="list-style-type: none"> When E506H is currently stored in buffer memory address 26446 (674EH) Detailed error code 1 is stored. (Refer to section 9.4.4) When a value other than E506H is currently stored in buffer memory address 26446 (674EH) Stored value: FFFFH (No detailed error code 1)
26450 (6752H)		<ul style="list-style-type: none"> When E506H is currently stored in buffer memory address 26446 (674EH) Detailed error code 2 is stored. (Refer to section 9.4.4) When a value other than E506H is currently stored in buffer memory address 26446 (674EH) Stored value: FFFFH (No detailed error code 2)
26451 (6753H)		<ul style="list-style-type: none"> When E506H is currently stored in buffer memory address 26446 (674EH) Detailed error code 3 is stored. (Refer to section 9.4.4) When a value other than E506H is currently stored in buffer memory address 26446 (674EH) Stored value: FFFFH (No detailed error code 3)
26452 (6754H) to 26484 (6774H)		Empty area Stored value: 0000H
26485 (6775H)		An error code is stored. ^① (Refer to section 9.4.4)
26486 (6776H)		<ul style="list-style-type: none"> When E508H is currently stored in buffer memory address 26485 (6775H) Detailed error code 1 is stored. ^① (Refer to section 9.4.4) When a value other than E508H is currently stored in buffer memory address 26485 (6775H) Stored value: FFFFH (No detailed error code 1) ^①
26487 (6777H)		<ul style="list-style-type: none"> When E508H is currently stored in buffer memory address 26485 (6775H) Detailed error code 2 is stored. ^① (Refer to section 9.4.4) When a value other than E508H is currently stored in buffer memory address 26485 (6775H) Stored value: FFFFH (No detailed error code 2) ^①
26488 (6778H)		<ul style="list-style-type: none"> When E508H is currently stored in buffer memory address 26485 (6775H) Detailed error code 3 is stored. ^① (Refer to section 9.4.4) When a value other than E508H is currently stored in buffer memory address 26485 (6775H) Stored value: FFFFH (No detailed error code 3) ^①
26489 (6779H) to 26528 (67A0H)	Alarm data No.2	(Same as alarm data No.1)
26529 (67A1H) to 26568 (67C8H)	Alarm data No.3	
26569 (67C9H) to 26608 (67F0H)	Alarm data No.4	
26609 (67F1H) to 26648 (6818H)	Alarm data No.5	
26649 (6819H) to 26688 (6840H)	Alarm data No.6	
26689 (6841H) to 26728 (6868H)	Alarm data No.7	
26729 (6869H) to 26768 (6890H)	Alarm data No.8	

Tab. 7-47: Response format (when failed) (2)

^① Data are stored only when the ACK response completion status is "Failed" (the corresponding bit in buffer memory address 26448 (6750H) is OFF).

7.5.4 Program example

Settings

The example program in this section uses the following example requests.

Item	Description
Service name	Alarm read request (with ACK)
DP-Slave FDL address	FDL address 1

Tab. 7-48: Details of program example

Assignment of devices in program example

The program examples in this section use the following device assignments.

- Devices occupied by the ME1PB1-L

Device (Input)	Description	Device (Output)	Description
X58	Alarm read response signal	Y58	Alarm read request signal

Tab. 7-49: List of devices for the ME1PB1-L

- Devices for the user

Device	Description	Device	Description
M0	ME1PB1-L is ready for communication (Refer to section 7.1.1)		—

Tab. 7-50: List of user devices

- Devices used as automatic refresh or buffer memory read target

Device	Description	Device	Description
D4000 to D4321	Alarm read request (with ACK) response area	M200 to M215	Slave status area (Alarm detection)

Tab. 7-51: List of devices used as automatic refresh or buffer memory read target

Program example

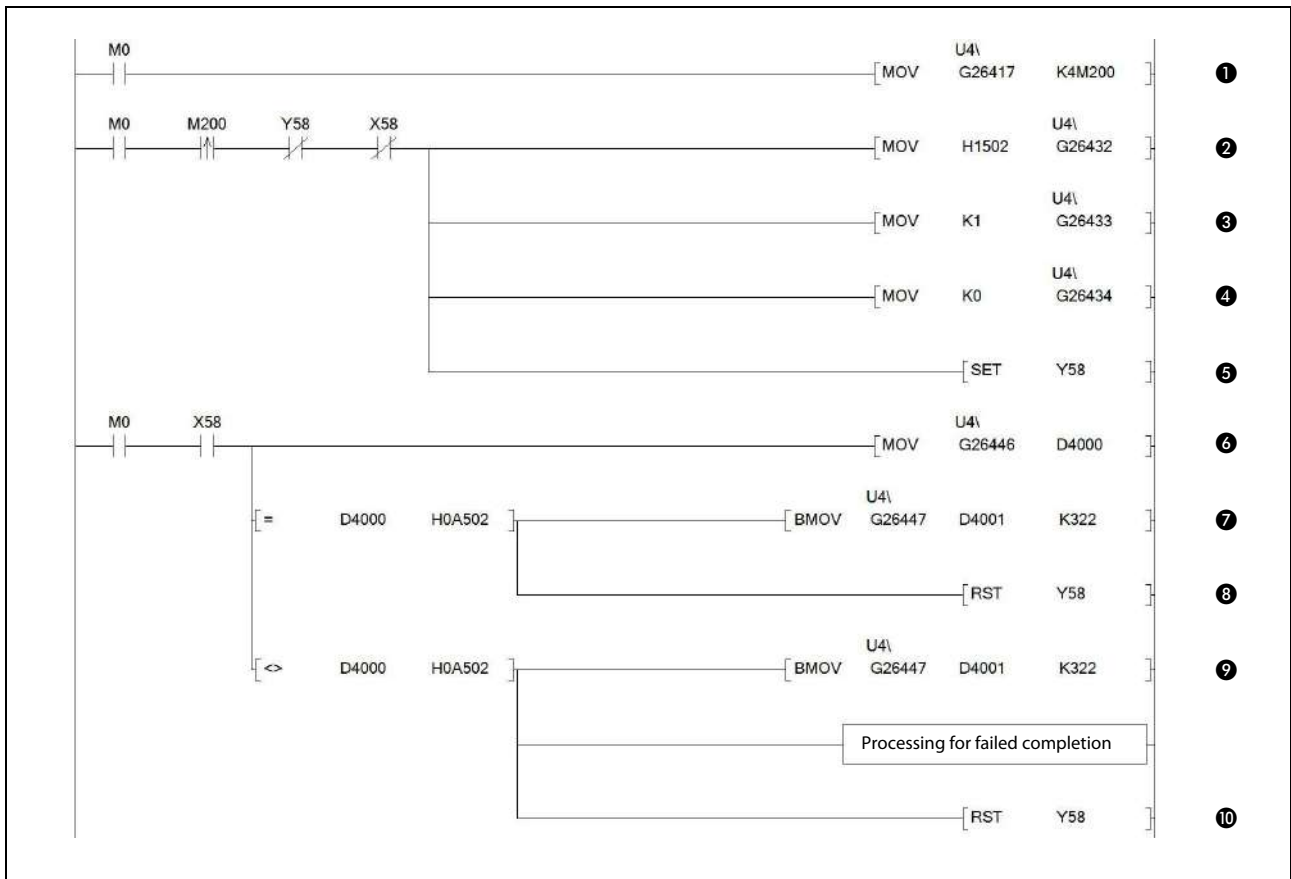

Fig. 7-18: Program example for alarm acquisition (alarm read (with ACK))

No.	Description
①	Reads the alarm status of each station.
②	The request code is set. (1502H)
③	The FDL address of the target DP-Slave is set (FDL address 1).
④	Empty area (0)
⑤	Executes alarm read.
⑥	Reads the response code and error code
⑦	Reads the execution result
⑧	When reading of the alarm is completed, the read request signal is reset.
⑨	Reads detailed error code
⑩	When reading of the alarm is completed, the read request signal is reset.

Tab. 7-52: Description of fig. 7-18

7.6 Program Example for Time Control over DP-Slaves

This section explains the request and response formats in the time control function, providing a program example.

Making a sequence program

For details on the program example, refer to section 7.6.4.

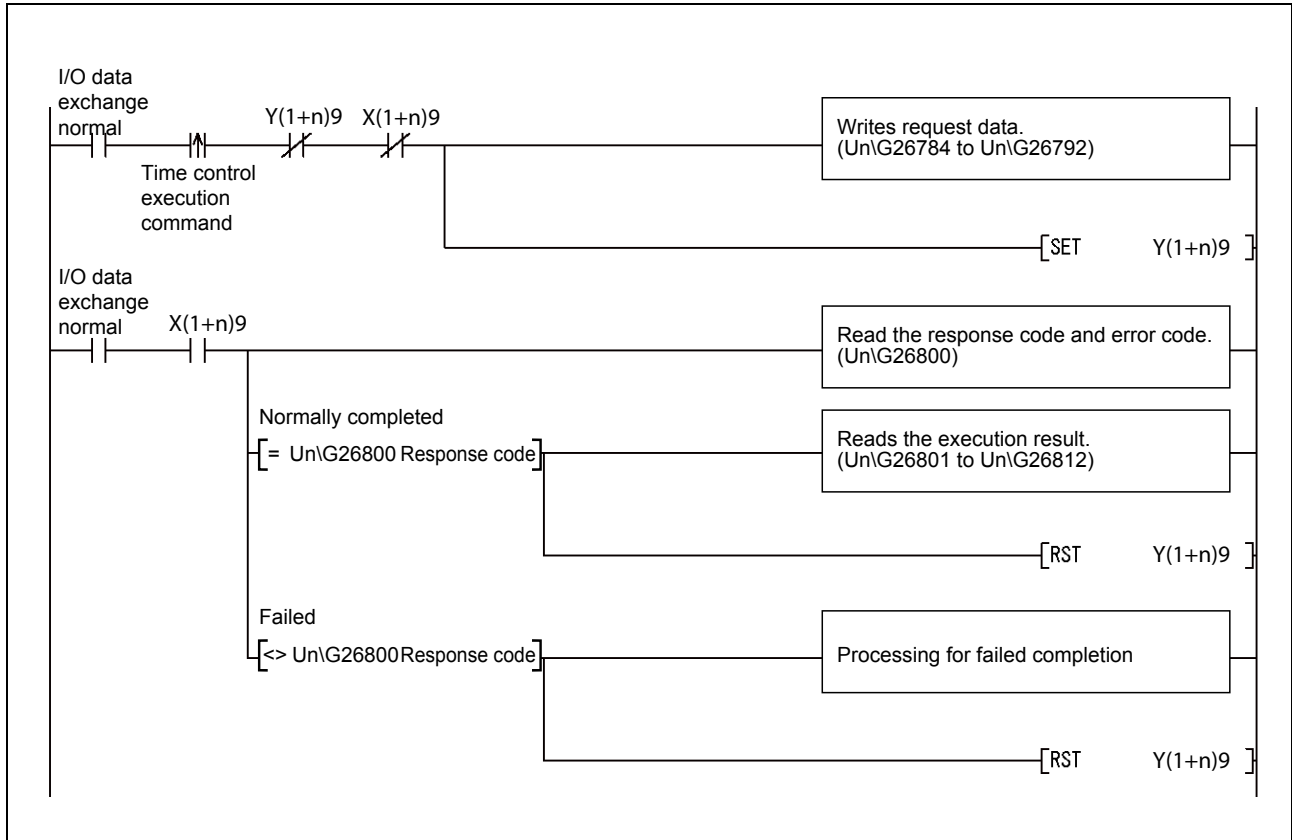

Fig. 7-19: Sequence program (time control function)

7.6.1 Time data read request

Request format

Buffer memory address	Description/Set value
26784 (68A0H)	Set a request code. (Set value: 1600H)
26785 (68A1H) to 26792 (68A8H)	Empty area (Write 0000H) (Set value: Fixed to 0000H)

Tab. 7-53: Time data read request format

Response format

- When normally completed

Buffer memory address	Result									
26800 (68B0H)	A response code is stored. (Stored value: A600H)									
26801 (68B1H)	The year is stored. (Stored value: 1984 to 2036)									
26802 (68B2H)	The month is stored. (Stored value: 1 to 12)									
26803 (68B3H)	The day is stored. (Stored value: 1 to 31)									
26804 (68B4H)	The hour is stored. (Stored value: 0 to 23)									
26805 (68B5H)	The minute is stored. (Stored value: 0 to 59)									
26806 (68B6H)	The second is stored. (Stored value: 0 to 59)									
26807 (68B7H)	1/1000 second is stored. (Stored value: 0 to 999)									
26808 (68B8H) 26809 (68B9H)	The UTC second (year + month + day + hour + minute + second) is stored. For example, the stored value, 9DFF4400H represents "January 1st in 1984, 00:00:00". (Stored value: 9DFF4400H to FFFFFFFFH)									
26810 (68BAH) 26811 (68BBH)	UTC nanosecond (ms to ns setting) is stored. (Stored value: 00000000H to FFFFFFFFH)									
26812 (68BCH)	<p>The clock status is stored.</p> <p>b15 b14 to b10 b9 b8 b7 b6 b5 b4 b3 b2 b1 b0</p> <table border="1" style="margin-left: 20px;"> <tr> <td style="text-align: center;">6</td> <td style="text-align: center;">5</td> <td style="text-align: center;">0</td> <td style="text-align: center;">4</td> <td style="text-align: center;">3</td> <td style="text-align: center;">0</td> <td style="text-align: center;">2</td> <td style="text-align: center;">0</td> <td style="text-align: center;">1</td> </tr> </table> <ul style="list-style-type: none"> ① Synchronous setting with the time master is stored. 0 : Not synchronize the time setting with that of the time master. 1 : Synchronize the time setting with that of the time master. ② Time resolution (minimum unit) setting is stored. 00 : 1 ms 01 : 10 ms 10 : 100 ms 11 : 1 s ③ Summer/Winter time setting is stored. 0 : Winter time setting 1 : Summer time setting ④ Advance notice of summer/winter time switching is stored. 0 : Not switch between summer and winter times in an hour 1 : Switches between summer and winter times in an hour ⑤ Time difference (the time to be added or subtracted) is stored. The value, 0 means "No addition or subtraction". Stored value: 0 to 31 (Unit: x 0.5 hours) ⑥ Time calculation method is stored. 0 : Adds the time difference 1 : Subtracts the time difference 	6	5	0	4	3	0	2	0	1
6	5	0	4	3	0	2	0	1		

Tab. 7-54: Response format (when normally completed)

- When failed

Buffer memory address	Result
26800 (68B0H)	An error code is stored. (Refer to section 9.4.5)
26801 (68B1H) to 26812 (68BCH)	Empty area (Stored value: 0000H)

Tab. 7-55: Response format (when failed)

7.6.2 Time data write request (UTC format)

Request format

Buffer memory address	Description/Set value									
26784 (68A0H)	Set a request code. (Set value: 1601H)									
26785 (68A1H) 26786 (68A2H)	Set the UTC second (year + month + day + hour + minute + second). For example, the set value, 9DFF4400H represents "January 1st in 1984, 00:00:00". (Set value: 9DFF4400H to FFFFFFFFH)									
26787 (68A3H) 26788 (68A4H)	Set UTC nanosecond (ms to ns setting). (Set value: 00000000H to FFFFFFFFH)									
26789 (68A5H)	<p>Set the clock status.</p> <p>b15 b14 to b10 b9 b8 b7 b6 b5 b4 b3 b2 b1 b0</p> <table border="1" style="margin-left: 20px;"> <tr> <td style="text-align: center;">6</td> <td style="text-align: center;">5</td> <td style="text-align: center;">0</td> <td style="text-align: center;">4</td> <td style="text-align: center;">3</td> <td style="text-align: center;">0</td> <td style="text-align: center;">2</td> <td style="text-align: center;">0</td> <td style="text-align: center;">1</td> </tr> </table> <p> 1 Set the synchronous setting with the time master. 0 : Not synchronize the time setting with that of the time master. 1 : Synchronize the time setting with that of the time master. 2 Set the time resolution (minimum unit). 00 : 1 ms 01 : 10 ms 10 : 100 ms 11 : 1 s 3 Set summer or winter time. 0 : Set winter time. 1 : Set summer time. 4 Set advance notice of summer/winter time switching. 0 : Not switch between summer and winter times in an hour 1 : Switches between summer and winter times in an hour 5 Set the time difference (the time to be added or subtracted). The value, 0 means "No addition or subtraction". Set value: 0 to 31 (Unit: x 0.5 hours) 6 Set the time calculation method. 0 : Adds the time difference 1 : Subtracts the time difference </p>	6	5	0	4	3	0	2	0	1
6	5	0	4	3	0	2	0	1		
26790 (68A6H) to 26792 (68A8H)	Empty area (Write 0000H.) (Set value: Fixed to 0000H)									

Tab. 7-56: Time data write request format

Response format

- When normally completed

Buffer memory address	Result
26800 (68B0H)	A response code is stored. (Stored value: A601H)
26801 (68B1H) to 26812 (68BCH)	Empty area (Stored value: 0000H)

Tab. 7-57: Response format (when normally completed)

- When failed

Buffer memory address	Result
26800 (68B0H)	An error code is stored. (Refer to section 9.4.5)
26801 (68B1H) to 26812 (68BCH)	Empty area (Stored value: 0000H)

Tab. 7-58: Response format (when failed)

7.6.3 Time data write request

Request format

Buffer memory address	Description/Set value									
26784 (68A0H)	Set a request code. (Set value: 1602H)									
26785 (68A1H)	Set the year. (Set value: 1984 to 2036)									
26786 (68A2H)	Set the month. (Set value: 1 to 12)									
26787 (68A3H)	Set the day. (Set value: 1 to 31)									
26788 (68A4H)	Set the hour. (Set value: 0 to 23)									
26789 (68A5H)	Set the minute. (Set value: 0 to 59)									
26790 (68A6H)	Set the second. (Set value: 0 to 59)									
26791 (68A7H)	Set 1/1000 second. (Set value: 0 to 999)									
26792 (68A8H)	<p>Set the clock status.</p> <p>b15 b14 to b10 b9 b8 b7 b6 b5 b4 b3 b2 b1 b0</p> <table border="1" style="margin-left: 20px;"> <tr> <td style="text-align: center;">6</td> <td style="text-align: center;">5</td> <td style="text-align: center;">0</td> <td style="text-align: center;">4</td> <td style="text-align: center;">3</td> <td style="text-align: center;">0</td> <td style="text-align: center;">2</td> <td style="text-align: center;">0</td> <td style="text-align: center;">1</td> </tr> </table> <p> 1 Set the synchronous setting with the time master. 0 : Not synchronize the time setting with that of the time master. 1 : Synchronize the time setting with that of the time master. </p> <p> 2 Set the time resolution (minimum unit). 00 : 1 ms 01 : 10 ms 10 : 100 ms 11 : 1 s </p> <p> 3 Set summer or winter time. 0 : Set winter time. 1 : Set summer time. </p> <p> 4 Set advance notice of summer/winter time switching. 0 : Not switch between summer and winter times in an hour 1 : Switches between summer and winter times in an hour </p> <p> 5 Set the time difference (the time to be added or subtracted). The value, 0 means "No addition or subtraction". Set value: 0 to 31 (Unit: x 0.5 hours) </p> <p> 6 Set the time calculation method. 0 : Adds the time difference 1 : Subtracts the time difference </p>	6	5	0	4	3	0	2	0	1
6	5	0	4	3	0	2	0	1		

Tab. 7-59: Time data write request format

Response format

- When normally completed

Buffer memory address	Result
26800 (68B0H)	A response code is stored. (Stored value: A602H)
26801 (68B1H) to 26812 (68BCH)	Empty area (Stored value: 0000H)

Tab. 7-60: Response format (when normally completed)

- When failed

Buffer memory address	Result
26800 (68B0H)	An error code is stored. (Refer to section 9.4.5)
26801 (68B1H) to 26812 (68BCH)	Empty area (Stored value: 0000H)

Tab. 7-61: Response format (when failed)

7.6.4 Program example

The example program in this section issues a time data write request. The time is set to ten o'clock and the date to the 1st July 2005.

Assignment of devices in program example

- Devices occupied by the ME1PB1-L

Device	Description	Device	Description
X59	Time control start response signal	Y59	Time control start request signal

Tab. 7-62: List of devices for the ME1PB1-L

- Devices for the user

Device	Description	Device	Description
X37	Time control execution command	M0	ME1PB1-L is ready for communication (refer to section 7.1.1)

Tab. 7-63: List of devices for the user

- Devices used as automatic refresh or buffer memory read target

Device	Description	Device	Description
D5000	Time data write request response area		—

Tab. 7-64: List of devices used as automatic refresh or buffer memory read target

Program example

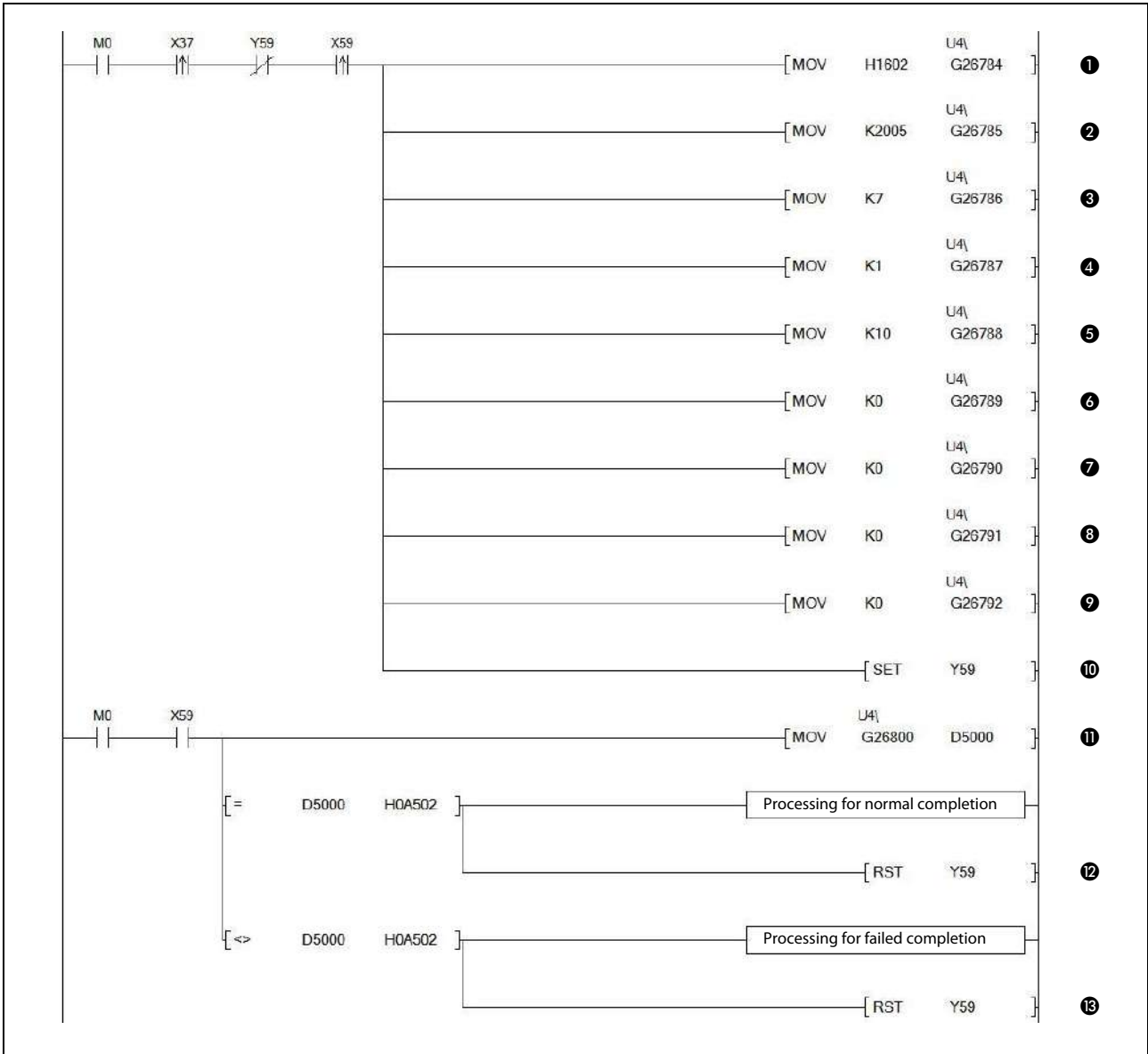

Fig. 7-20: Program example for time control function (time data write request)

No.	Description
①	Request code is set (1602H)
②	Year is set. (2005)
③	Month is set. (July)
④	Day is set (1st).
⑤	Hour is set. (10 o'clock).
⑥	Minute is set. (0 minutes).
⑦	Second is set. (0 seconds)
⑧	1/000 second value is set. (0)
⑨	Clock status is set. (0)
⑩	Time control is executed.
⑪	Reads the response code and error code
⑫	When time control is completed, the read request signal is reset.
⑬	

Tab. 7-65: Description of fig. 7-20

7.7 Program Example for Temporary Slave Reservation

For a program example for temporary slave reservation, please refer to sections 7.1.1 to 7.1.3.

NOTE

The program for the temporary slave reservation must be executed before turning ON the Data exchange start request signal (Yn0). (Refer to sections 7.1.1 to 7.1.3)

7.8 Program Examples when the ME1PB1-L is Mounted to a CC-Link IE Field Network Head Module

This section presents program examples for the case where the ME1PB1-L is mounted to a CC-Link IE Field Network head module. These example cover the I/O data exchange function.

In the first example, the auto refresh function is used for data exchange between the CC-Link IE Field Network head module and the ME1PB1-L.

The second example shows the usage of the dedicated instructions REMFR and REMTO for the data exchange.

NOTE

The dedicated instructions used for reading/writing the buffer memory of an intelligent function module on a remote station (REMTO and REMFR) take several CPU scans for their execution. Therefore, transmissions of the execution results are not synchronized with the I/O signal operations. Please refer to the "CC-Link IE Field Network master/local module user's manual" for details of the REMFR/REMTO instructions.

7.8.1 System configuration for the examples

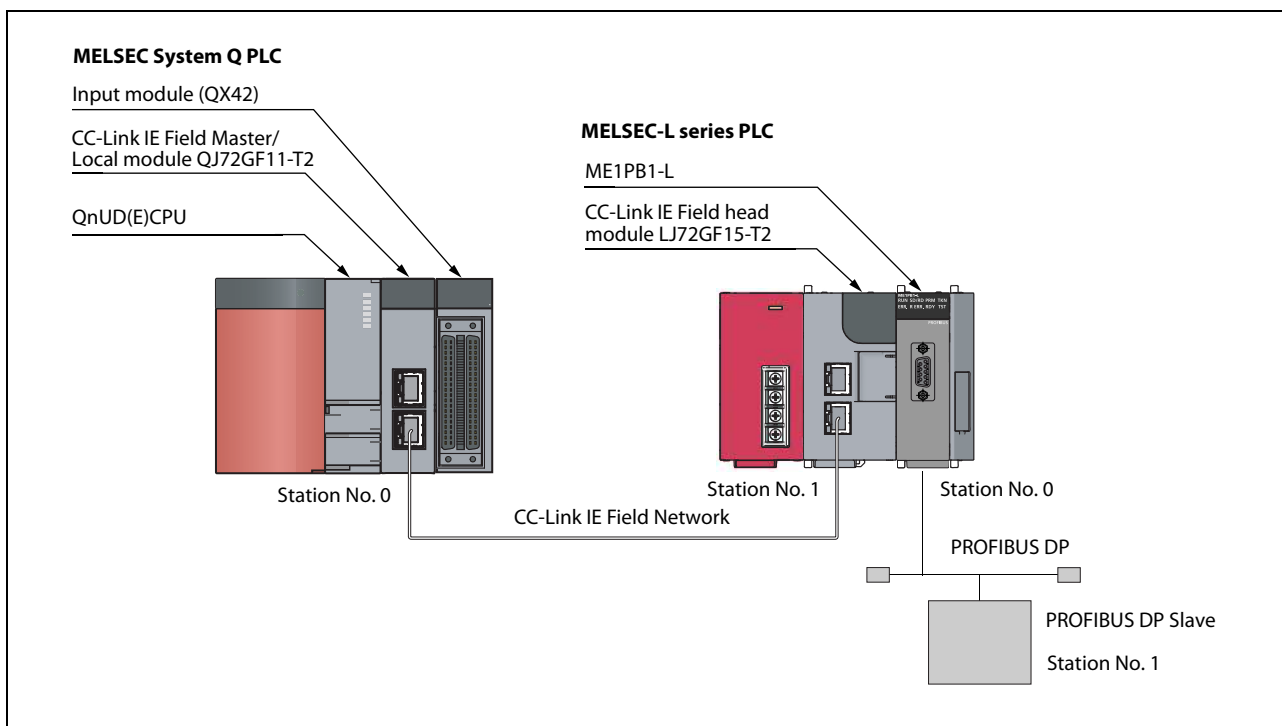

Fig. 7-21: In this example the ME1PB1-L is mounted to a CC-Link IE Field head module.

7.8.2 I/O Assignment for both examples

CC-Link IE Field Master station

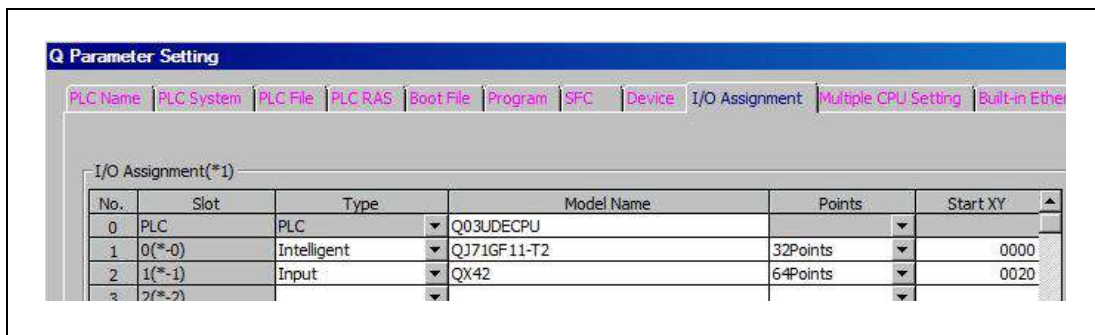

Fig. 7-22: I/O assignment for the CC-Link IE Field Master station

Module	Input signals	Output signals
QJ71GF11-T2	X00 to X1F	Y00 to Y1F
QX42	X20 to X5F	—

Tab. 7-66: Assignment of input and output signals for the master station

CC-Link IE Field intelligent device station

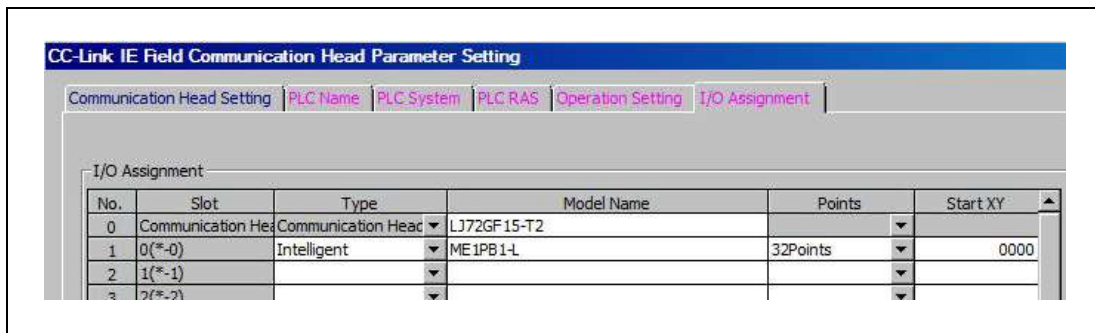

Fig. 7-23: I/O assignment for the CC-Link IE Field intelligent device station

Module	Input signals	Output signals
ME1PB1-L	X00 to X1F	Y00 to Y1F

Tab. 7-67: Assignment of input and output signals for the intelligent device station

7.8.3 Use of auto refresh for transfer of input/output data

Data flow

- Reading of inputs and writing of outputs (X/Y signals) of the ME1PB1-L

X/Y signals of the ME1PB1-L are refreshed into link devices (RX/RX) of the CC-Link IE Field network. Refresh setting between RX/RX and CPU devices (e.g. X/Y) is necessary.

- Buffer memory access for ME1PB1-L

For the areas where auto refresh is supported, it is possible to use auto refresh between the CC-Link IE Field head module and the ME1PB1-L.

NOTE

With auto refresh, the data consistency function is not supported.

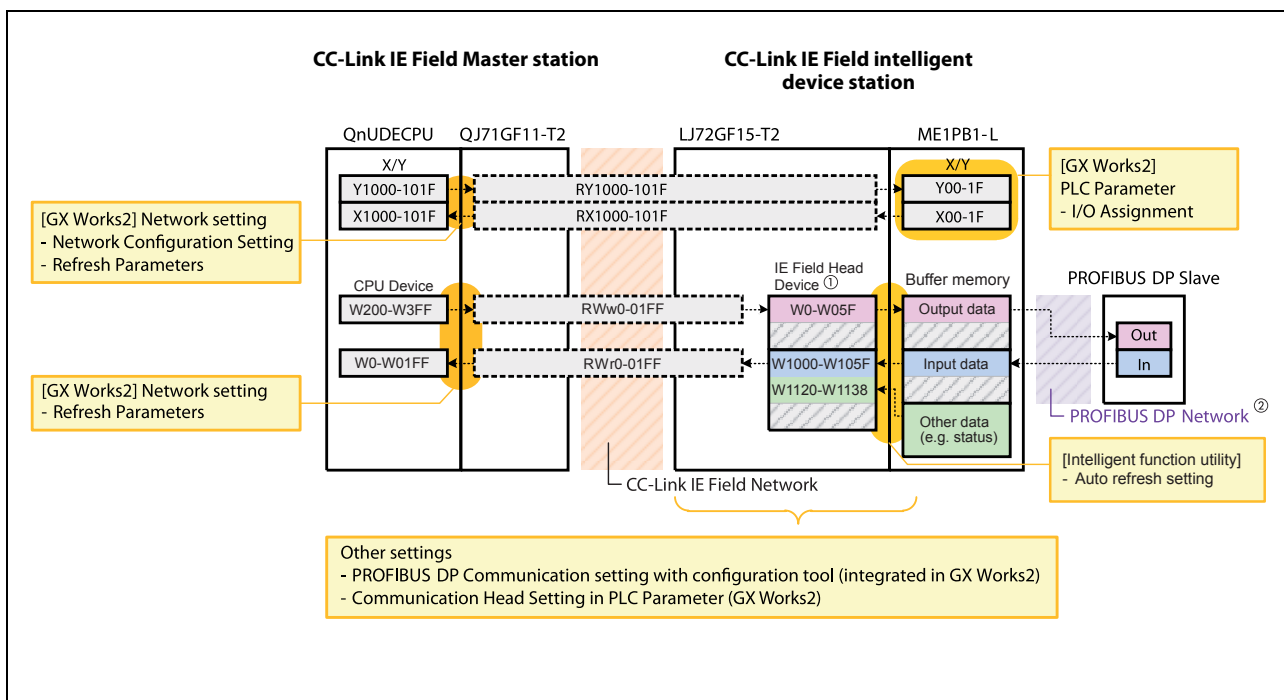
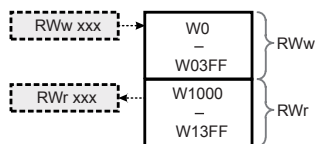

Fig. 7-24: Data flow for data exchange with auto refresh

① CC-Link IE Field Head device is predefined according to the following mapping:



② Data consistency between the head module LJ72GF15-T2 and the ME1PB1-L is not supported. To access buffer memory areas where auto refresh is not supported, the dedicated instructions REMFR/REMTO are necessary.

Setting of network parameter

- CC-Link IE Field Master station

	Module 1
Network Type	CC IE Field (Master Station)
Start I/O No.	0000
Network No.	1
Total Stations	1
Group No.	
Station No.	0
Mode	Online (Normal Mode)
	Network Configuration Settings
	Network Operation Settings
	Refresh Parameters
	Interrupt Settings
	Specify Station No. by Parameter

Fig. 7-25: Network Parameter for the CC-Link IE Field Master station

Item	Set value
Network Type	CC IE Field (Master Station)
Start I/O No.	0000
Network No.	1
Total Stations	1
Mode	Online (Normal mode)

Tab. 7-68: List of network parameters

After setting the items shown above, click on **Network Configuration Settings**. Enter the following.

Set up Network configuration.													
Assignment Method		The column contents for refresh device will be changed corresponding to refresh parameter setting contents. Please reopen the window after completing refresh parameter setting when changing refresh parameter.											
<input type="radio"/> Points/Start <input checked="" type="radio"/> Start/End													
Number of Station	Station No.	Station Type	RX/Ry Setting			RWw/RWr Setting			Refresh Device				
			Points	Start	End	Points	Start	End	RX	RY	RWw	RWr	
0	0	Master Station											
1	1	Intelligent Device Station	32	1000	101F	512	0000	01FF	X1000(32)	Y1000(32)	W200(512)	W0(512)	

Fig. 7-26: Network configuration settings for the CC-Link IE Field Master station

Item	Set value
Station No.	1
Station Type	Intelligent Device Station
RX/Ry Setting	1000 to 101F
RWw/RWr Setting	0000 to 01FF

Tab. 7-69: Network configuration list

Next, click on **Refresh Parameters** to bring up the following dialogue. This is where the settings for the data exchange between the CC-Link IE Field Master station and the PLC CPU will be made. Enter the values shown below.

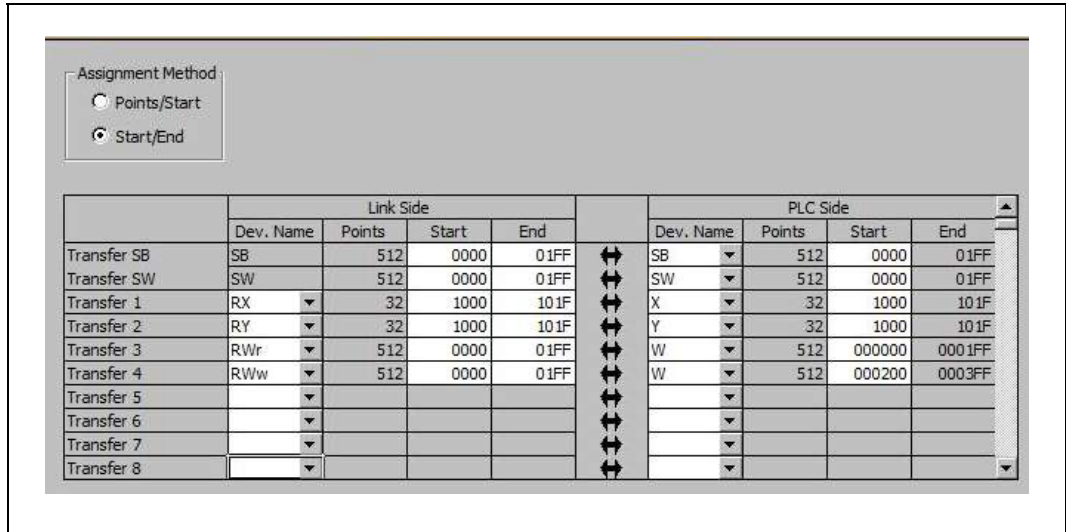

Fig. 7-27: Refresh parameters for the CC-Link IE Field Master station

Transfer	Device	Link Side	PLC Side
Transfer SB	SB	SB0000 to SB01FF	SB0000 to SB01FF
Transfer SW	SW	SW0000 to SW01FF	SW0000 to SW01FF
Transfer 1	RX	RX1000 to RX101F	X1000 to X101F
Transfer 2	RX	RY1000 to RY101F	Y1000 to Y101F
Transfer 3	RWr	RWr0000 to RWr01FF	W0000 to W01FF
Transfer 4	RWw	RWw0000 to RWr01FF	W00200 to W03FF

Tab. 7-70: Refresh parameter list

- CC-Link IE Field intelligent device station

In the PLC parameter of the intelligent device station, set the following:

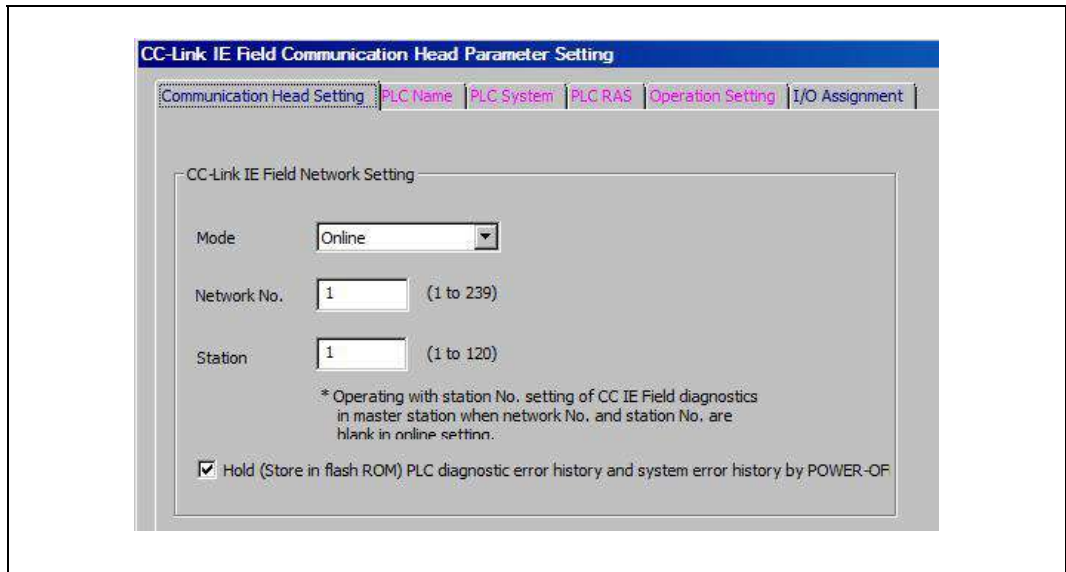

Tab. 7-71: I/O assignment for the CC-Link IE Field intelligent device station

Item	Set value
Mode	Online
Network No.	1
Station No. *	1

Tab. 7-72:

List of network parameters for the intelligent device station

* The Station No. of the CC-Link IE Field Network head module can also be set in the CC-Link IE Field diagnostics of GX Works2.

PROFIBUS DP settings

The PROFIBUS parameter settings for the ME1PB1-L and the DP-Slaves are the nearly same as those explained in section 7.1. For this example the following auto refresh setting is required.

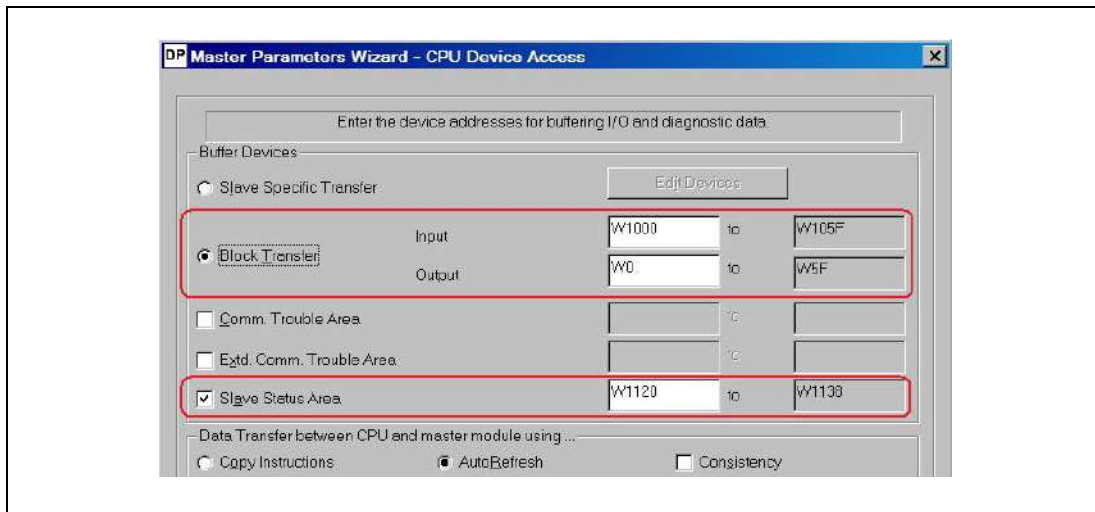

Fig. 7-28: Auto refresh settings

Device	Description	
W1000 to W105F	Input data	
W0 to W5F	Output data	
W1120 to W1127	Slave status	Normal communication
W1128 to W1130		Reserved station
W1131 to W1138		Diagnostic information

Tab. 7-73:

List of automatically refreshed devices

The settings shown above are for the transfer of data between the buffer memory of the PROFIBUS Master and the CC-Link IE Field Network head module (please refer also to fig. 7-24).

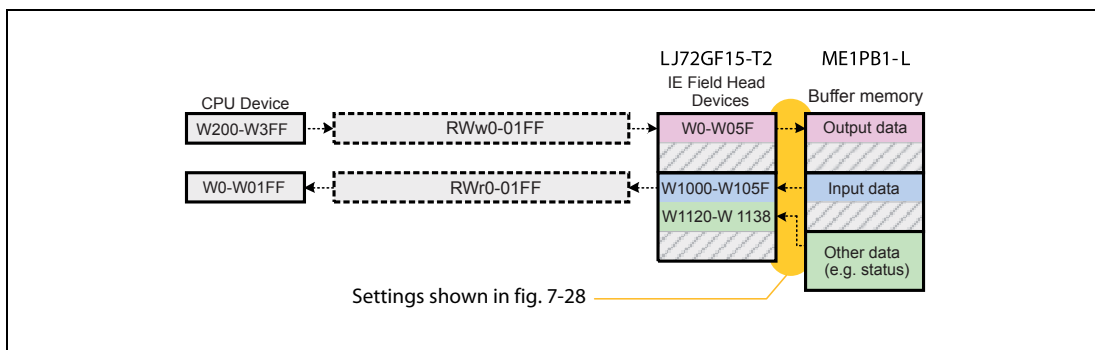

Fig. 7-29: Effects of the auto refresh settings

For a detailed description of the internal data handling of the head module refer to the CC-Link IE Field Network head module's manual.

Assignment of devices for the program example

- Devices occupied by the ME1PB1-L

Device (Input)	Description	Device (Output)	Description
X1000	Data exchange start completed signal	Y1000	Data exchange start request signal
X101B	Communication READY signal	—	
X101D	Module READY signal		
X101F	Watchdog timer error signal		

Tab. 7-74: List of devices for the ME1PB1-L

- Devices for the user

PLC CPU device			Link special relay/register (CC-Link IE Field)	
Device	Description		Device	Description
X30	I/O data exchange start command		SB49	Data link status (own station)
X3E	Conditions for write to output data	1st word	—	Data link status (each station) (station No. 1)
X3F		2nd word		
M0	ME1PB1-L is ready for communication			
M1	Used for MC instruction			
M300	ON for 1 scan only after start of communication to set initial setting			
M301	Interlock for writing initial setting			
M302	For holding I/O data exchange run			
M1000	REMTO instruction to write initial setting (Diagnostics information invalid)	Complete		
M1001		Error		
M1002	REMTO instruction to write initial setting (Diagnostic information non-notification time)	Complete		
M1003		Error		

Tab. 7-75: List of devices for the user

- Devices used for data exchange with the buffer memory of the ME1PB1-L

Device	Description		Device	Description
W1000 to W105F*	Input data		D6000	Diagnostic information invalid setting area
W0 to W5F*	Output data		D6001	Diagnostic information non-notification time setting area
W1120 to W1127*	Slave status area	Normal communication	—	
W1128 to W1130*		Reserved station		
W1131 to W1138*		Diagnostic information		

Tab. 7-76: List of devices used for data exchange with the buffer memory

* The data transfer between the buffer memory of the ME1PB1-L and the CC-Link IE Field devices is set in the PROFIBUS DP auto refresh settings (refer to fig. 7-28). The data transfer between the CC-Link IE Field devices and the PLC devices is set in the refresh parameters of the CC-Link IE Field Master station (refer to fig. 7-27).

Program

- Interlock program for CC-Link IE Field Master and head module

The communication between CC-Link IE Field Master and IE Field Network head module should be active to access the ME1PB1-L from the QCPU.

The following shows an interlock program example by the data link status of the head module (station number 1).

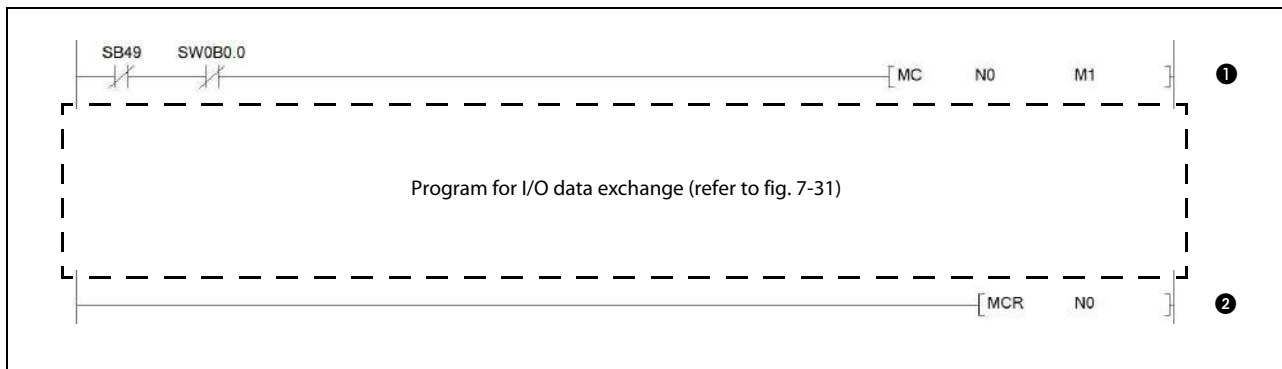

Fig. 7-30: Program example for checking the data link status of the

No.	Description
①	When the communication with the CC-Link IE Field Network head module is possible, the master control instruction is switched ON.
②	Master control reset (Only when the input condition for the MC instruction (①) is set, the instructions between the MC and the MCR instruction are executed.)

Tab. 7-77: Description of fig. 7-30

NOTE

For details of the interlock program for the CC-Link IE Field master station and CC-Link IE Field Network head module, please refer to the MELSEC-Q CC-Link IE Field Network Master/Local Module User's Manual.

● I/O data exchange program example

NOTE

The following program for initial setting of the ME1PB1-L and I/O data exchange will only be executed if the input condition of the master control instruction is set, i.e. M1 is "1". (Refer to fig. 7-30)

The program part for initial setting is not necessary when default setting is used.

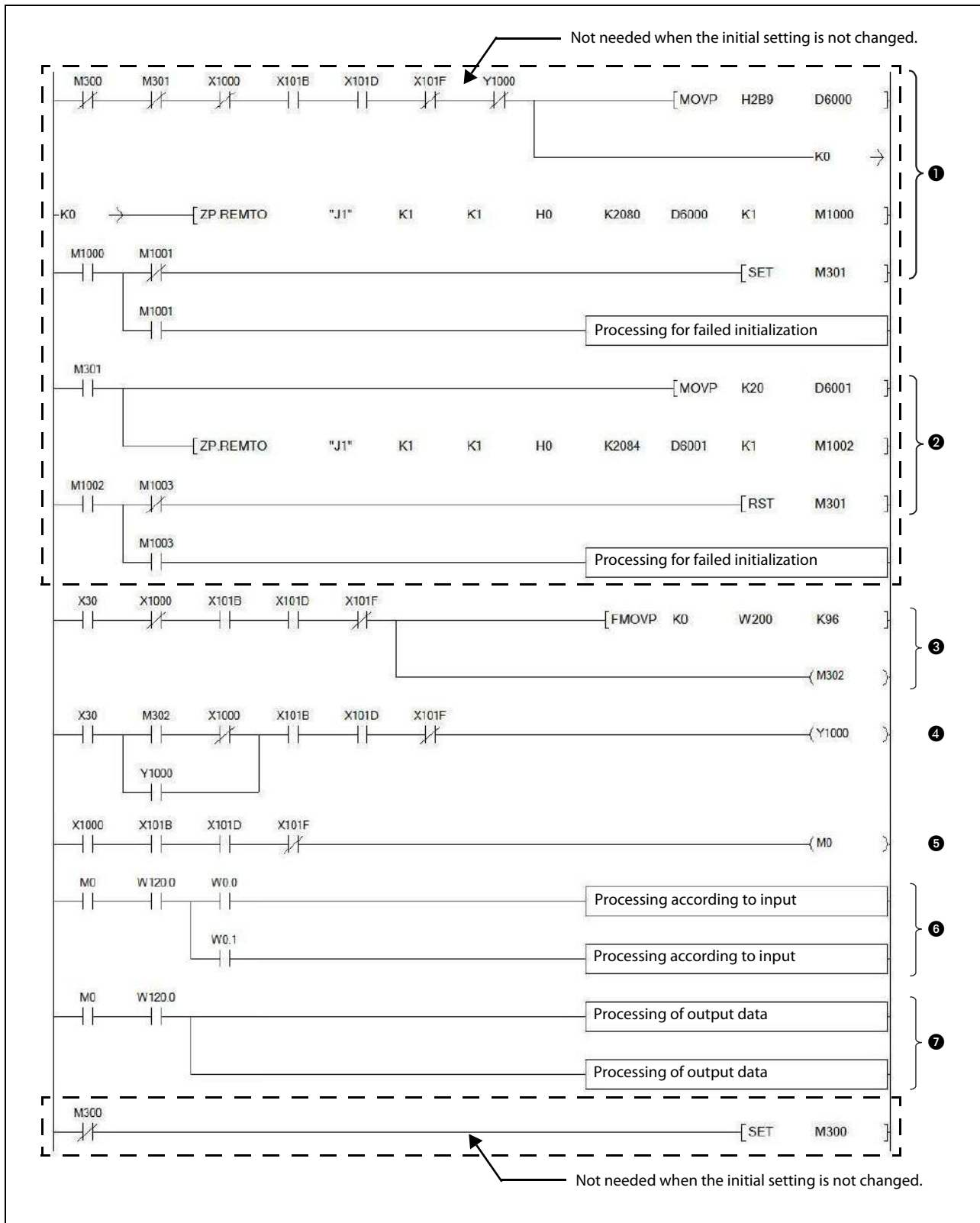

Fig. 7-31: Program example for I/O data exchange function with auto refresh

No.	Description
①	Initializing Diagnostic information invalid setting area
②	Initializing Diagnostic information non-notification time setting area
③	Writing the initial value of output data
④	I/O data exchange start processing
⑤	When the ME1PB1-L is ready for communication, M0 is ON
⑥	When the ME1PB1 and the DP-Slave are ready for communication, the input data is processed.
⑦	The output data is prepared when the ME1PB1 and the DP-Slave are ready for communication.

Tab. 7-78: Description of fig. 7-31

7.8.4 Use of REMTO/REMFR instructions for transfer of input/output data

Data flow

- Reading of inputs and writing of outputs (X/Y signals) of the ME1PB1-L
 X/Y signals of the ME1PB1-L are refreshed into link devices (RX/RX) of the CC-Link IE Field network. Refresh setting between RX/RX and CPU devices (e.g. X/Y) is necessary.
- Buffer memory access for ME1PB1-L
 Dedicated instructions REMFR/REMTO are used to access the buffer memory of the ME1PB1-L.

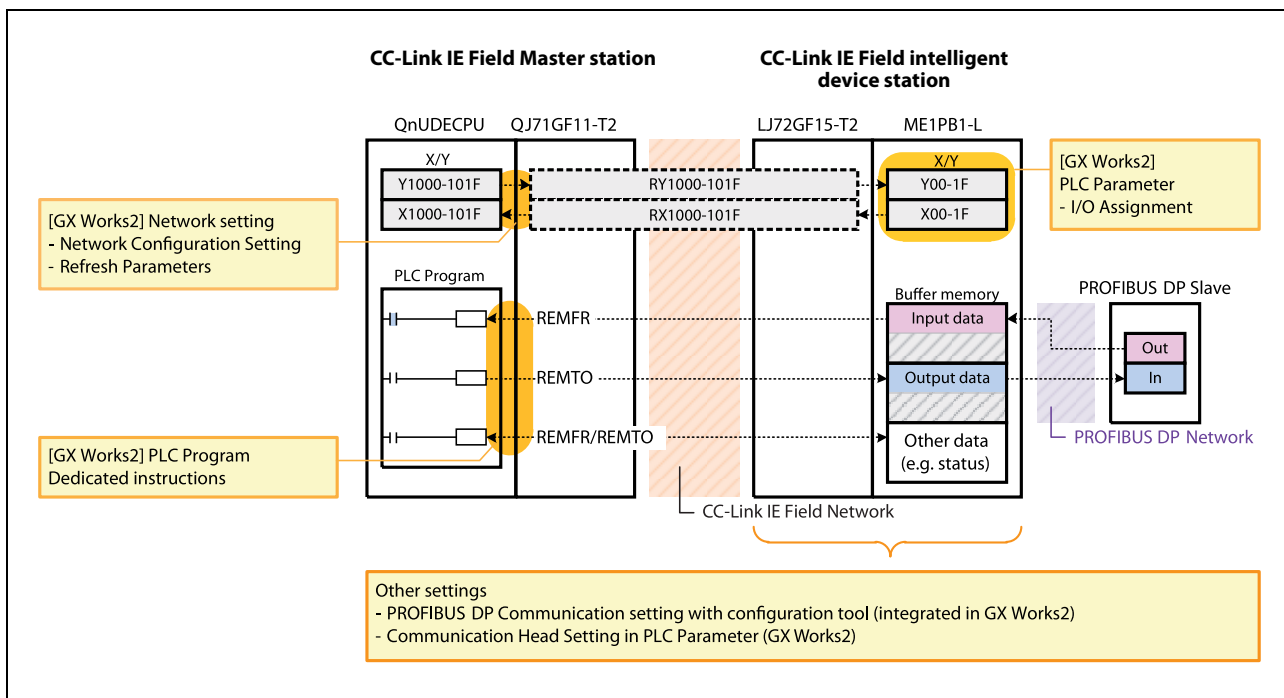

Fig. 7-32: Data flow for data exchange with REMTO/REMFR instructions

Setting of network parameter

- CC-Link IE Field Master station

	Module 1
Network Type	CC IE Field (Master Station)
Start I/O No.	0000
Network No.	1
Total Stations	1
Group No.	
Station No.	0
Mode	Online (Normal Mode)
	Network Configuration Settings
	Network Operation Settings
	Refresh Parameters
	Interrupt Settings
	Specify Station No. by Parameter

Fig. 7-33: Network Parameter for the CC-Link IE Field Master station (Same as in the previous example)

Item	Set value
Network Type	CC IE Field (Master Station)
Start I/O No.	0000
Network No.	1
Total Stations	1
Mode	Online (Normal mode)

Tab. 7-79: List of network parameters

After setting the items shown above, click on **Network Configuration Settings**. Enter the following.

Set up Network configuration.

Assignment Method
 Points/Start
 Start/End

The column contents for refresh device will be changed corresponding to refresh parameter setting contents. Please reopen the window after completing refresh parameter setting when changing refresh parameter.

Number of Points	Station No.	Station Type	RX/RX Setting			RWw/RWw Setting			Refresh Device		
			Points	Start	End	Points	Start	End	RX	RY	RWw
0	0	Master Station									
1	1	Intelligent Device Station	32	1000	101F			X 1000(32)	Y 1000(32)		

Fig. 7-34: Network configuration settings for the CC-Link IE Field Master station

Item	Set value
Station No.	1
Station Type	Intelligent Device Station
RX/RX Setting	1000 to 101F

Tab. 7-80: Network configuration list

Next, click on **Refresh Parameters** to bring up the following dialogue. This is where the settings for the data exchange between CC-Link IE Field and the PLC CPU will be made. Enter the values shown below.

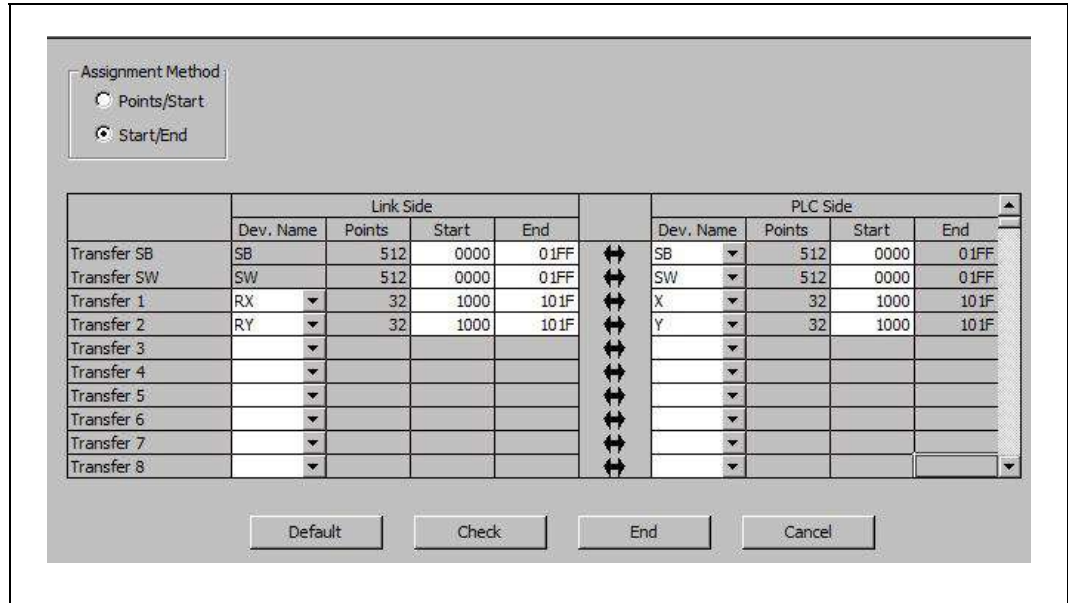

Fig. 7-35: Refresh parameters for the CC-Link IE Field Master station

Transfer	Device	Link Side	PLC Side
Transfer SB	SB	SB0000 to SB01FF	SB0000 to SB01FF
Transfer SW	SW	SW0000 to SW01FF	SW0000 to SW01FF
Transfer 1	RX	RX1000 to RX101F	X1000 to X101F
Transfer 2	RX	RY1000 to RY101F	Y1000 to Y101F

Tab. 7-81: Refresh parameter list

- CC-Link IE Field intelligent device station

In the PLC parameter of the intelligent device station, set the following:

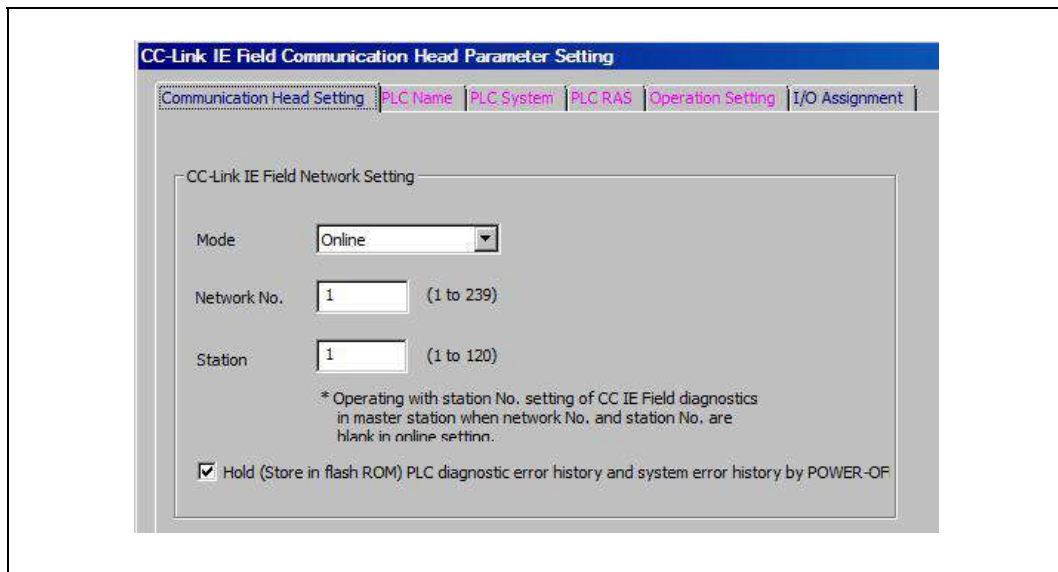

Tab. 7-82: I/O assignment for the CC-Link IE Field intelligent device station (same as in the previous example)

Item	Set value
Mode	Online
Network No.	1
Station No. *	1

Tab. 7-83:

List of network parameters for the intelligent device station

* The Station No. of the CC-Link IE Field Network head module can also be set in the CC-Link IE Field diagnostics of GX Works2.

PROFIBUS DP settings

The PROFIBUS parameter settings for the ME1PB1-L and the DP-Slaves are the same as those explained in section 7.1.

Assignment of devices for the program example

- Devices occupied by the ME1PB1-L

Device (Input)	Description	Device (Output)	Description
X1000	Data exchange start completed signal	Y1000	Data exchange start request signal
X101B	Communication READY signal	—	
X101D	Module READY signal		
X101F	Watchdog timer error signal		

Tab. 7-84: List of devices for the ME1PB1-L

- Devices for the user

PLC CPU device			Link special relay/register (CC-Link IE Field)	
Device	Description		Device	Description
X30	I/O data exchange start command		SB49	Data link status (own station)
X3E	Conditions for write to output data	1st word	SW00B0.0	Data link status (each station) (station No. 1)
X3F		2nd word		
M0	ME1PB1-L is ready for communication		—	
M1	Used for MC instruction			
M300	ON for 1 scan only after start of communication to set initial setting			
M301	Interlock for writing initial setting			
M302	For holding I/O data exchange run			
M303	Interlock for reading status/input data and writing output data			
M304				
M1000	REMTO instruction to write initial setting	Complete		
M1001	(Diagnostics information invalid)	Error		
M1002	REMTO instruction to write initial setting	Complete		
M1003	(Diagnostic information non-notification time)	Error		
M1004	REMTO instruction to write initial value of output data	Complete		
M1005		Error		
M1006	REMFR instruction to read input data	Complete		
M1007		Error		
M1008	REMFR instruction to read slave status	Complete		
M1009		Error		
M1010	REMTO instruction to write output data	Complete		
M1011		Error		

Tab. 7-85: List of devices for the user

- Devices used for data exchange with the buffer memory

Device	Description	Device	Description
D0 to D95	Input data	D6000	Diagnostic information invalid setting area
D100 to D195	Output data	D6001	Diagnostic information non-notification time setting area
D200 to D207	Slave status area	Normal communication	—
D208 to D215		Reserved station	
D216 to D224		Diagnostic information	

Tab. 7-86: List of devices used as buffer memory read target

Program

- Interlock program for CC-Link IE Field Master and head module

The communication between CC-Link IE Field Master and IE Field Network head module should be active to access the ME1PB1-L from the QCPU.

The following shows an interlock program example by the data link status of the head module (station number 1).

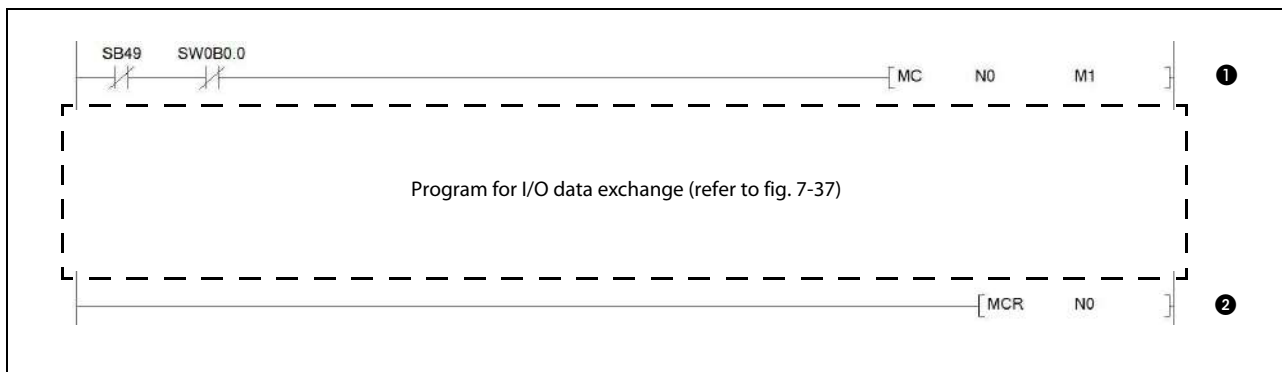

Fig. 7-36: Program example for checking the data link status of the

No.	Description
①	When the communication with the CC-Link IE Field Network head module is possible, the master control instruction is switched ON.
②	Master control reset (Only when the input condition for the MC instruction (①) is set, the instructions between the MC and the MCR instruction are executed.)

Tab. 7-87: Description of fig. 7-30

NOTE

For details of the interlock program for the CC-Link IE Field master station and CC-Link IE Field Network head module, please refer to the MELSEC-Q CC-Link IE Field Network Master/Local Module User's Manual.

● I/O data exchange program example

NOTE

The following program for initial setting of the ME1PB1-L and I/O data exchange will only be executed if the input condition of the master control instruction is set, i.e. M1 is "1". (Refer to fig. 7-30)

The program part for initial setting is not necessary when default setting is used.

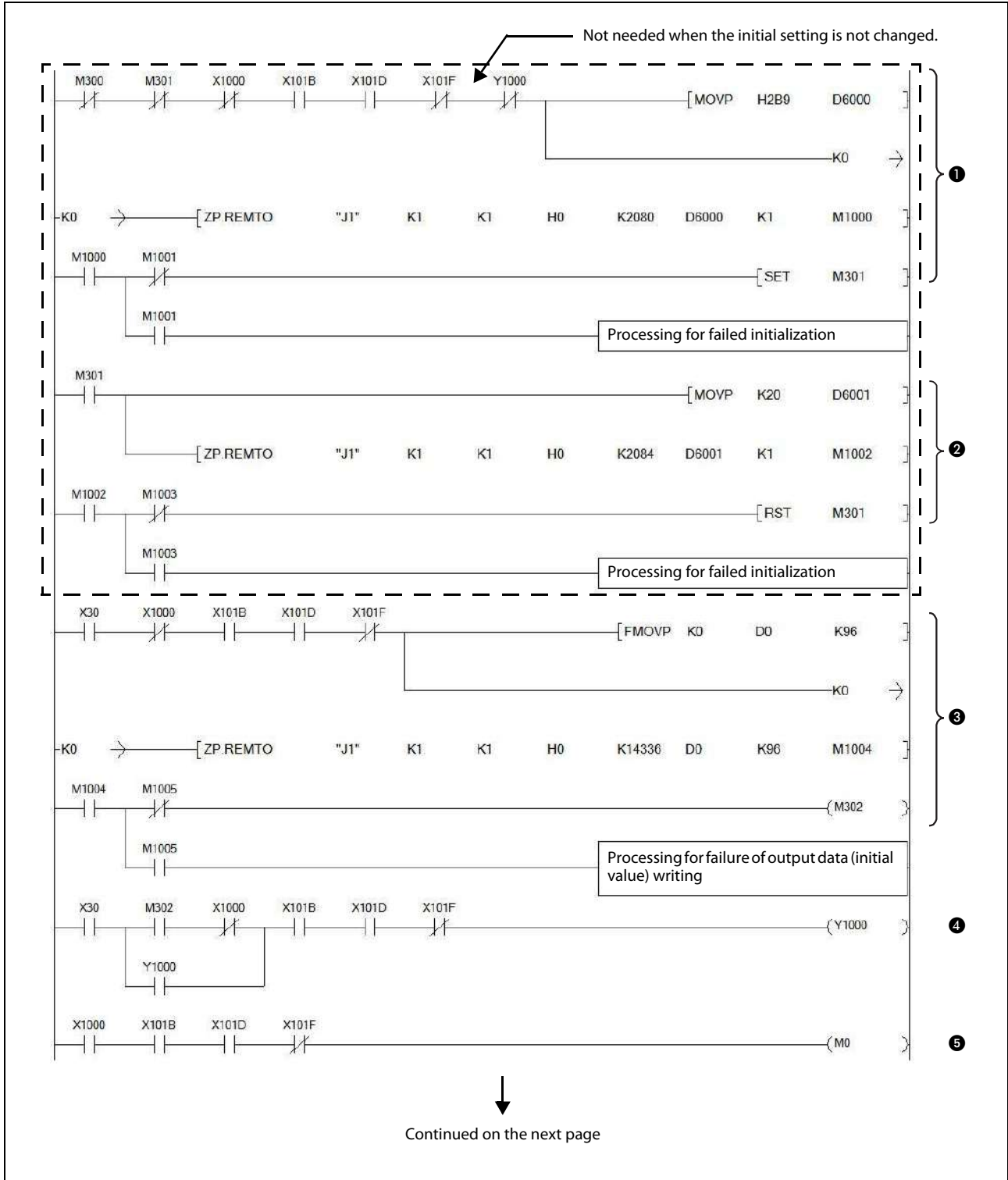

Continued on the next page

Fig. 7-37: Program example for the I/O data exchange using REMTO/REMFR instructions (1)

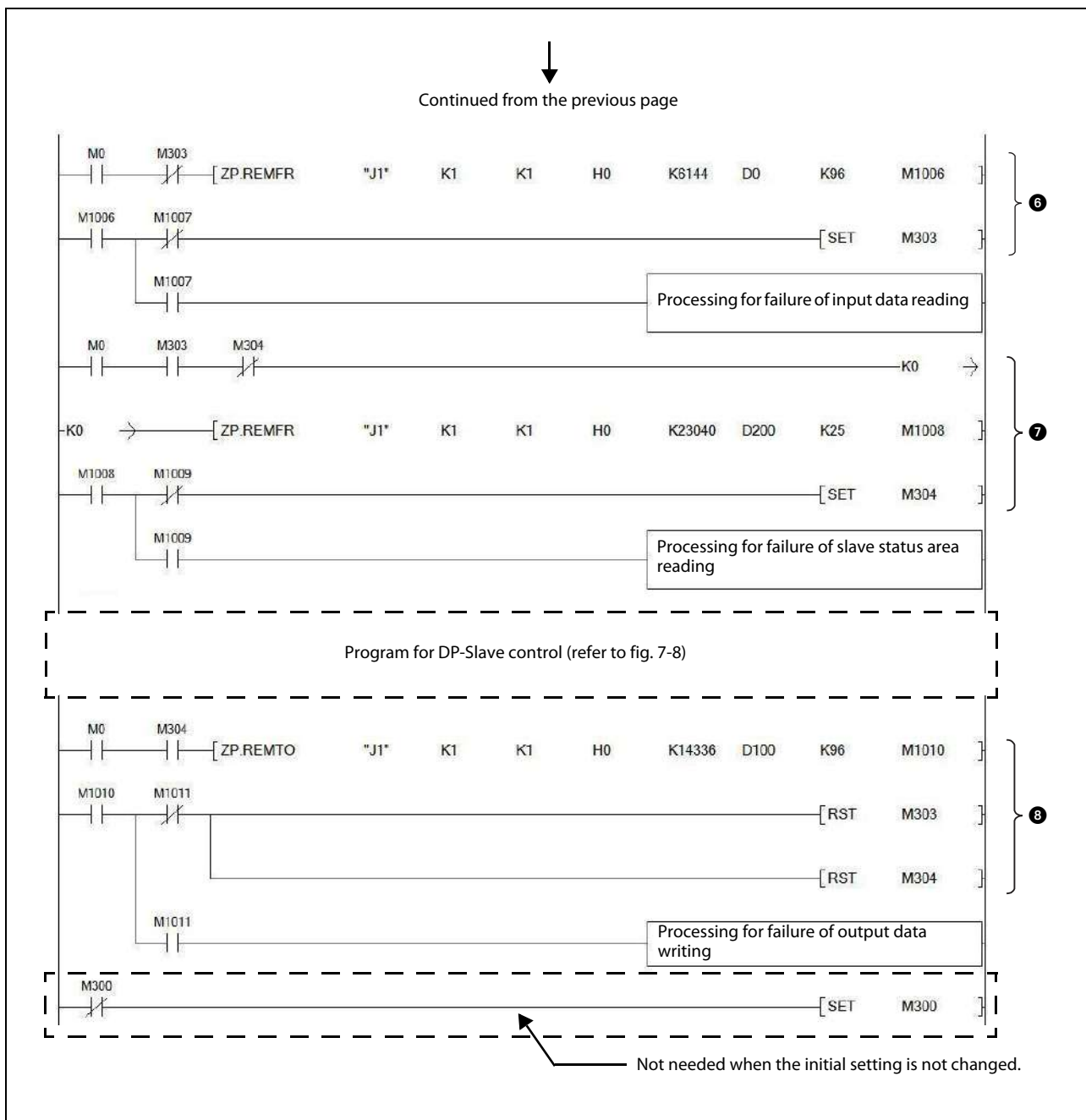

Fig. 7-37: Program example for the I/O data exchange using REMTO/REMFR instructions (2)

No.	Description
①	Initializing Diagnostic information invalid setting area
②	Initializing Diagnostic information non-notification time setting area
③	Clearing the input are, writing the initial value of output data
④	I/O data exchange start processing
⑤	When the ME1PB1-L is ready for communication, M0 is ON
⑥	Reading of input data
⑦	Reading Slave status area
⑧	Writing of output data

Tab. 7-88: Description of fig. 7-31

8 Dedicated Instructions

A "dedicated instruction" is defined as an instruction designed to make programming easy for use of the intelligent function module functionality.

This chapter describes the dedicated functions available for the ME1PB1-L.

List of dedicated functions

The following list shows the dedicated instructions available for the ME1PB1-L.

Dedicated instruction	Description	Reference
BBLKRD	Reads data from the buffer memory of a specified module, ensuring data consistency.	Section 8.2
BBLKWR	Writes data to the buffer memory of a specified module, ensuring data consistency.	Section 8.3

Tab. 8-1: List of dedicated instructions

Usable devices

The following devices are available for dedicated instructions.

Internal device		File register	Constant ^①
Bit	Word		
—	T, ST, C, D, W	R, ZR	K, H

Tab. 8-2: Usable devices

^① Available devices are given in the field "Constant" in each section.

8.1 Precautions for Dedicated Instructions

Before executing a dedicated instruction

Before executing a dedicated instruction, be sure to confirm the following.

- Turn ON the Data consistency start request signal (YnC)

Attempting to execute a dedicated instruction with the Data consistency start request signal (YnC) OFF will result in non-processing (non-execution).

Use the Data consistency requesting signal (XnC) as an interlock for execution of dedicated instructions.

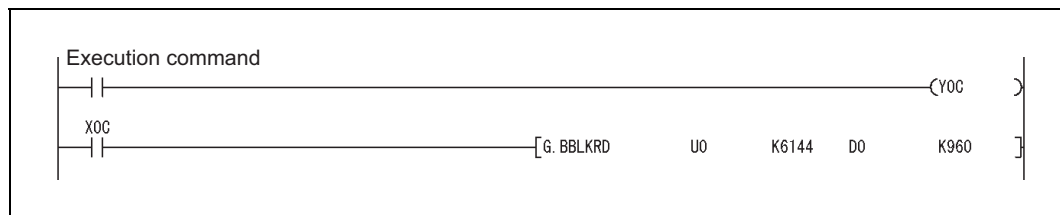

Fig. 8-1: Interlock example for dedicated instruction

- Check that consistency is disabled with automatic refresh enabled.

If the automatic refresh and data consistency functions are enabled, use of dedicated instructions is not allowed. (They are not processed.)

Dedicated instructions are executable if the data consistency function is disabled in the automatic refresh setting. (Refer to section 6.3)

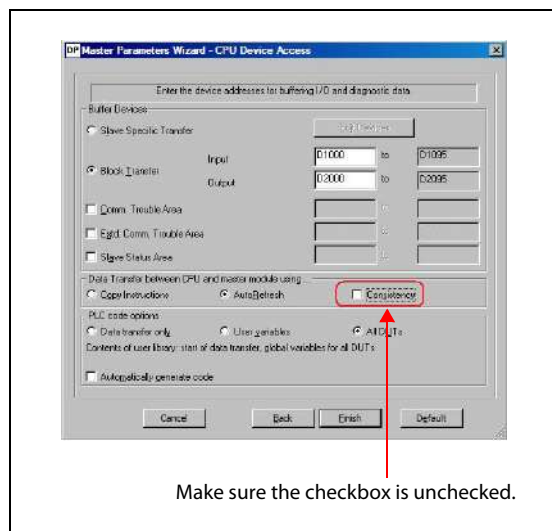

Fig. 8-2: Data consistency in automatic refresh

- The BBLKRD and BBLKWR instructions must be used in pair

Use the BBLKRD and BBLKWR instructions as a pair, and always execute them once for every sequence scan.

If only one of these instructions is used, an error code is stored in the Local station error information area (Un\G23071). (Refer to section 9.4.6)

- Execution timing

Execute the BBLKRD and BBLKWR instructions all the time.

While the ME1PB1-L is implementing the data consistency function, the dedicated instruction is not processed (not executed). (Refer to section 4.5)

Therefore, I/O data may not be read or written in a program where either of the instructions is executed only once at the rising or falling edge of the pulse.

- When mounted with a CC-Link IE head station

Dedicated instructions are not executable when the ME1PB1-L is mounted to a CC-Link IE head station.

- Transmission delay time when using a dedicated instruction

Use of the data consistency function increases the transmission delay time. (Refer to section 3.7)

8.2 G. BBLKRD

Set data	Usable device								
	Internal device (System, user)		File register	Link direct device J□□		Intelligent function module device U□\G□	Index register Zn	Constant K, H	Other
	Bit	Word		Bit	Word				
n1	—	●	●	—	—	—	—	●	—
d	—	●	●	—	—	—	—	—	—
n2	—	●	●	—	—	—	—	●	—

Tab. 8-3: Devices usable in the BBLKRD instruction

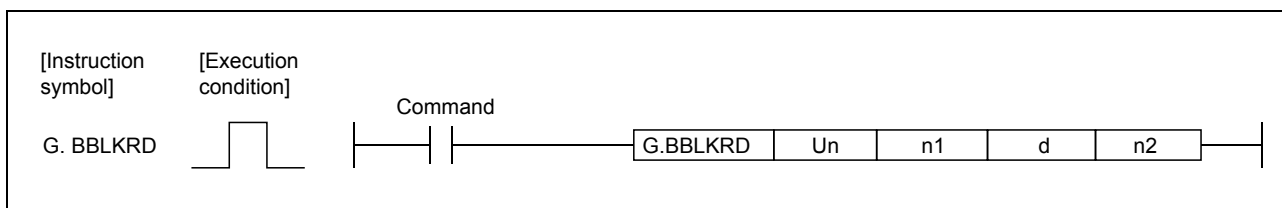

Fig. 8-3: BBLKRD instruction

Set data

Set data	Description	Setting range	Data type
Un	ME1PB1-L module start I/O number Upper 2 digits of the I/O number in 3-digit notation	0 to FEH	BIN 16 bits
n1	Start address of reading data	Specified device range	
d	Start No. of the device to which read data are stored	Specified device range	Device name
n2	Number of read data	1 to 4096 (word)	BIN 16 bits

Tab. 8-4: Set data in the BBLKRD instruction

Function

This instruction allows data reading from the buffer memory of a specified module with data consistency ensured.

Error

An operation error occurs in the following instances. (Error code: 4101)

- When a value outside the setting range is set to the set data field
- When the size, which is obtained by adding the number of read data to the start address of reading data, exceeds the buffer memory size
- When the points available for the start address of reading data or after is less than the number of read data.

Example ▾

Program example

At the timing of M10 = ON, data of 960 points are read to D0 to D959 from address 6144 (1800H) of the Input data area (for mode 3) of the ME1PB1-L (module start I/O No. 0) with data consistency ensured.

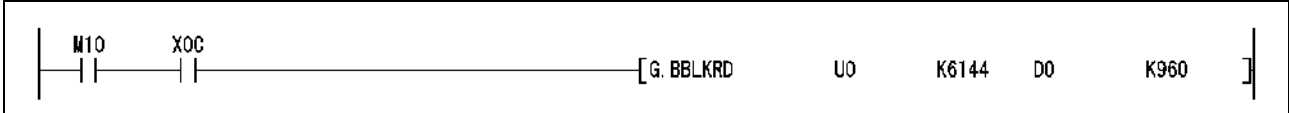

Fig. 8-4: BBLKRD instruction program example



8.3 G. BBLKWR

Set data	Usable device								
	Internal device (System, user)		File register	Link direct device J□□		Intelligent function module device U□\G□	Index register Zn	Constant K, H	Other
	Bit	Word		Bit	Word				
n1	—	●	●	—	—	—	—	●	—
s	—	●	●	—	—	—	—	—	—
n2	—	●	●	—	—	—	—	●	—

Tab. 8-5: Devices usable in the BBLKWR instruction

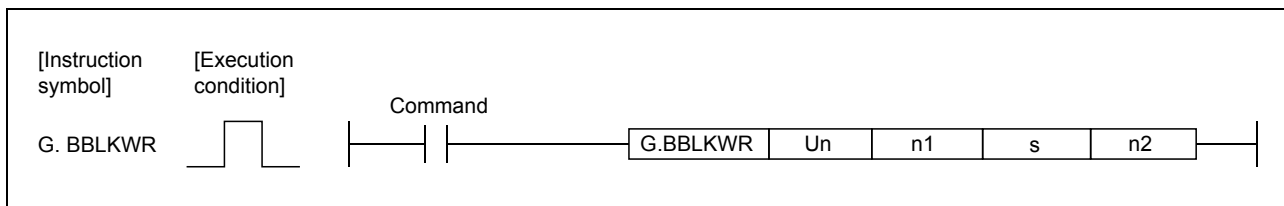

Fig. 8-5: BBLKWR instruction

Set data

Set data	Description	Setting range	Data type
Un	ME1PB1-L module start I/O number Upper 2 digits of the I/O number in 3-digit notation	0 to FEH	BIN 16 bits
n1	Start address for writing data	Specified device range	
s	Start No. of the device storing write data	Specified device range	Device name
n2	Number of write data	1 to 4096 (word)	BIN 16 bits

Tab. 8-6: Set data in the BBLKWR instruction

Function

This instruction allows data writing to the buffer memory of a specified module with data consistency ensured.

Error

An operation error occurs in the following instances. (Error code: 4101)

- When a value outside the setting range is set to the set data field
- When the size, which is obtained by adding the number of write data to the start address for writing data, exceeds the buffer memory size
- When the points available for the start address for writing data or after is less than the number of write data.

Example ▾

Program example

At the timing of M 10 = ON, data of 960 points in D0 to D959 are written to the Output data area (for mode 3) of the ME1PB1-L (module start I/O No.0) with data consistency ensured, starting from address 14336 (3800H).

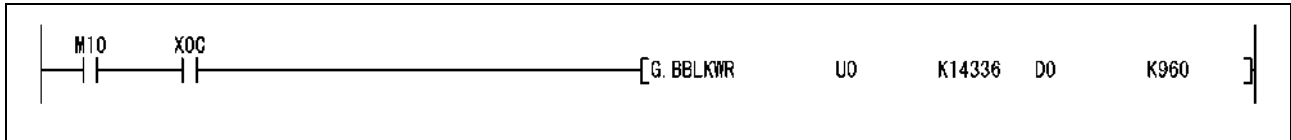

Fig. 8-6: BBLKWR instruction program example



9 Troubleshooting

This chapter explains the troubleshooting and error codes of the ME1PB1-L.

Before troubleshooting the ME1PB1-L, check that no errors have occurred on the LCPU or CC-Link IE Field network.

If any error is identified, check the error details and take corrective actions.

For the troubleshooting in sections 9.1 to 9.4, refer to the following flowchart.

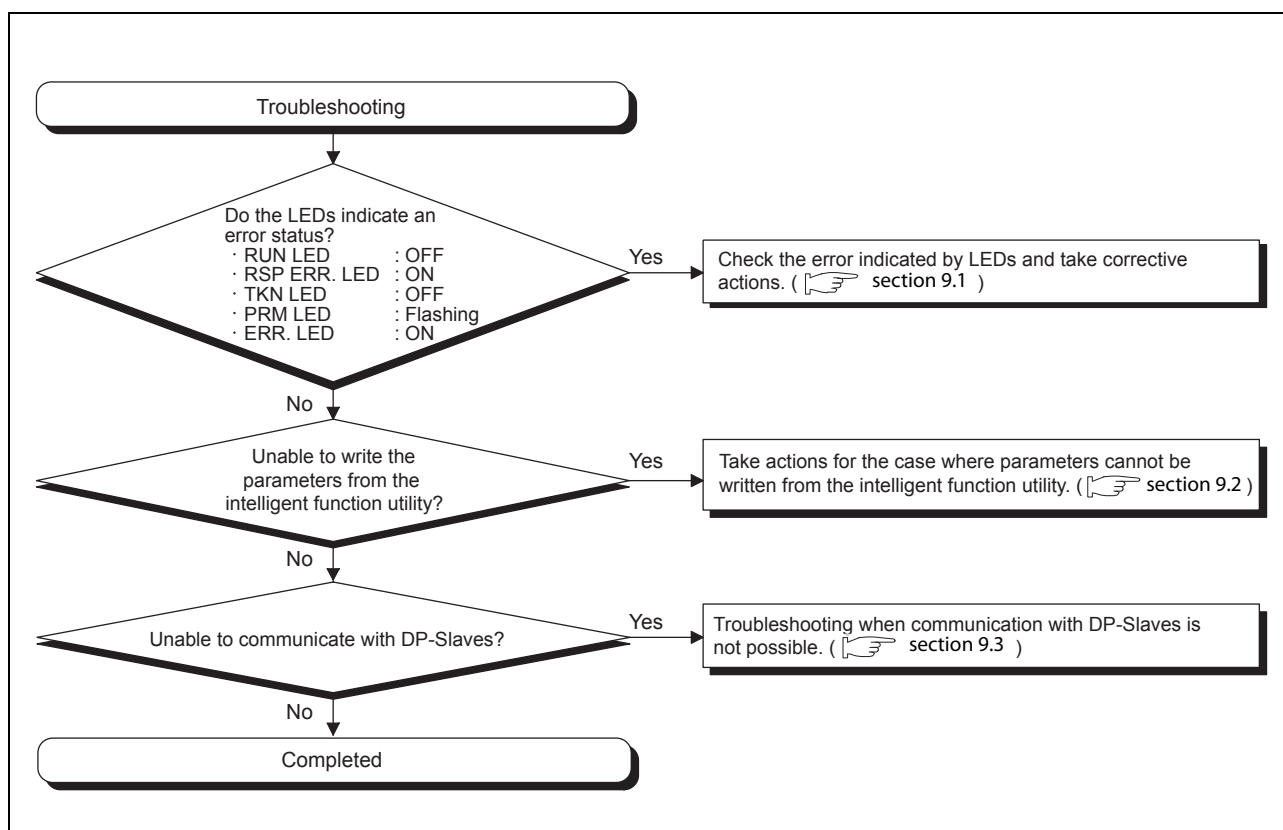

Fig. 9-1: Troubleshooting flowchart

9.1 Error Check Using the LEDs and Corrective Actions

This section explains how to check errors by the LEDs or by checking the LED status on the programming software.

9.1.1 Causes and actions

The following table summarizes causes that can be thought from the LED status of the ME1PB1-L and corrective actions to be taken.

LED	Status	Cause	Action
RUN	OFF	The watchdog monitoring time has been exceeded.	Please consult your local Mitsubishi representative, explaining a detailed description of the problem.
R ERR.	ON	A communication error has occurred.	Read the diagnostic information from the Diagnostic information area (for mode 3) (Un\G23072 to Un\G23321).
TKN	OFF	The token is not being rotated. ①	<ul style="list-style-type: none"> • Check the PROFIBUS cable connections. (Refer to section 5.5.2) • Check if the bus terminator is connected. (Refer to section 5.5.2) • Check if the FDL address of each station is unique. (Refer to sections 6.3 and 6.5) • Check if the FDL address does not exceed the HSA. (Refer to section 6.4)
		A multi master system with a transmission rate up to 93.75 kbps is used.	This is inside the specifications of the ME1PB1-L and does not mean an error. (Refer to section 5.3.1)
PRM	Flashing	Parameters in the flash ROM are corrupted.	Initialize the ME1PB1-L (initialization of the flash ROM) and write parameters again. (Refer to section 9.5)
		Downloaded parameter are not valid.	Check if the type of module type is correct for the parameter.
ERR.	ON	The FDL address of a DP-Slave is duplicated with that of the DP-Master in parameter settings.	Check the parameters. (Refer to sections 6.3 and 6.5)
		Parameters in the flash ROM are corrupted.	Initialize the ME1PB1-L (initialization of the flash ROM) and write parameters again. (Refer to section 9.5)
		An unexpected error other than the above has occurred.	Please consult your local Mitsubishi representative, explaining a detailed description of the problem.

Tab. 9-1: Faults indicated by the LEDs of the ME1PB1-L

9.1.2 Checking the LED status on GX Works2

The status of the ME1PB1-L's LEDs can be also checked on the H/W Information screen of GX Works2. For checking the LED status, use GX Works2 Version 8.8S or later.

Start procedure

Diagnostics → **System monitor** → **H/W Information**

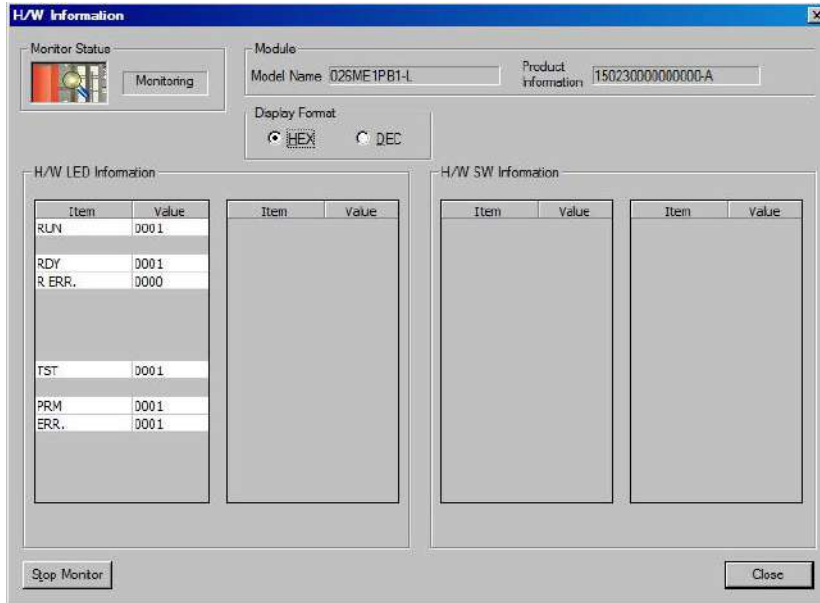

Fig. 9-2: "H/W Information" screen

Value	Description
0000	The LED on the ME1PB1-L is OFF.
0001	The LED on the ME1PB1-L is ON.
Displaying "0000" and "0001" alternately.	The LED on the ME1PB1-L is flashing.

Tab. 9-2: Values displayed at H/W LED information

9.2 When Parameters cannot be Written from GX Works2

The following shows the troubleshooting procedures to be taken when parameters cannot be written to the ME1PB1-L from the intelligent function utility.

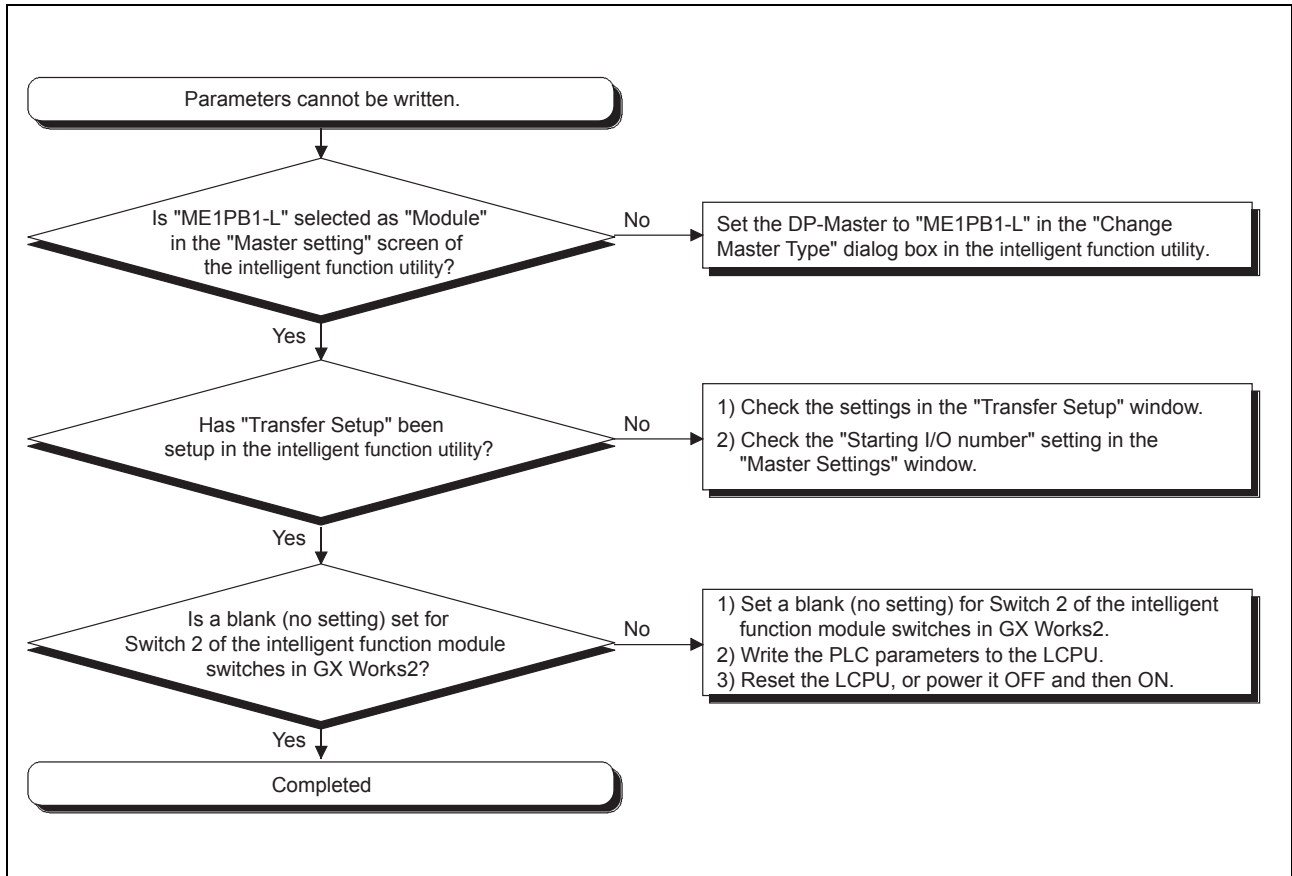

Fig. 9-3: When parameters cannot be written to the ME1PB1-L

9.3 When Communication with DP-Slaves is not Possible

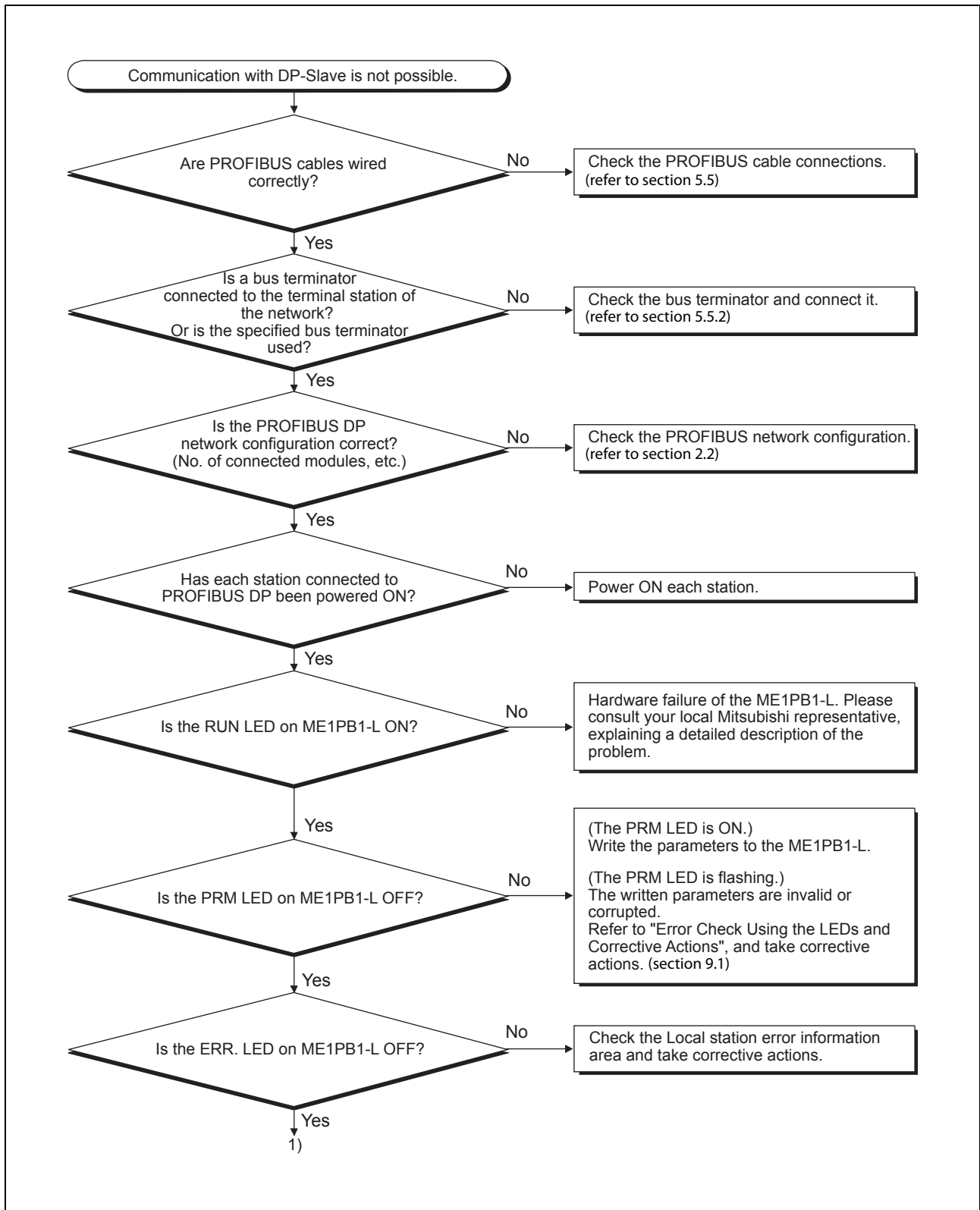

Fig. 9-4: Troubleshooting when communications with DP-Slaves are not possible (1)

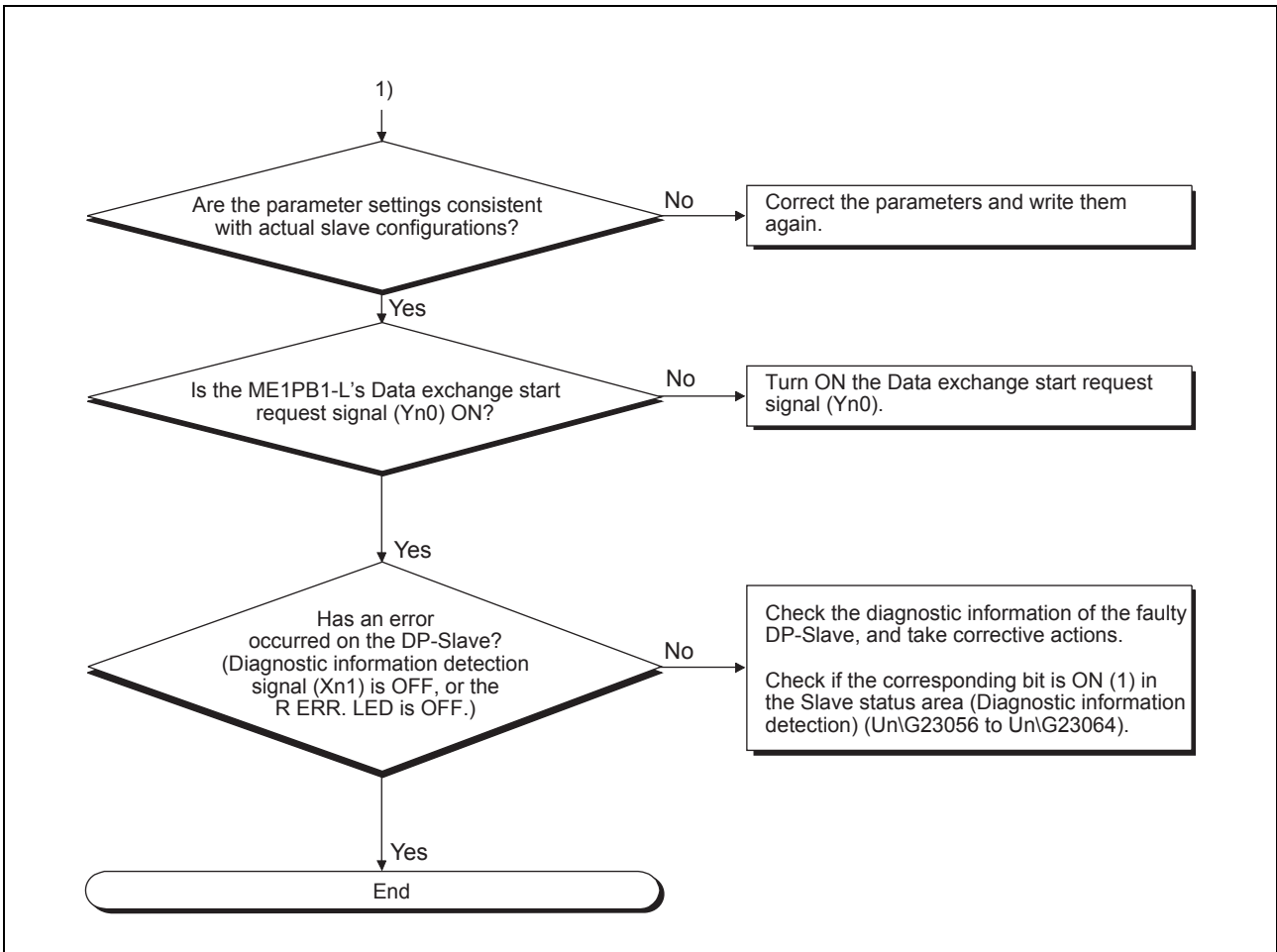

Fig. 9-4: Troubleshooting when communications with DP-Slaves are not possible (2)

9.4 Error Codes

This section explains the error codes that are output on the ME1PB1-L.

The ME1PB1-L error codes are classified by groups with error No.

The following table lists the groups of the error codes and the areas where they are stored.

Error codes	Classification	Storage location (Buffer memory address)	Reference (section)
E200H to E2FFH	Error codes generated when reading extended diagnostic error information	Extended diagnostic information read response area (Address: 23457 (5BA1H))	9.4.1
E300H to E3FFH	Error codes generated during operation mode switching	Operation mode change result area (Address: 2256 (8D0H))	9.4.2
E400H to E4FFH	Error codes generated during acyclic communication	Acyclic communication response area (Address: 25121 to 26144 (6221H to 6620H))	9.4.3
E500H to E5FFH	Error codes generated when reading alarms	Alarm response area (Address: 26446 to 26768 (674EH to 6890H))	9.4.4
E600H to E6FFH	Error codes generated during execution of time control	Time control setting response area (Address: 26800 (68B0H))	9.4.5
F100H to F1FFH	Diagnostic information of local station ① (ME1PB1-L)	Local station error information area (Address: 23071 (5A1FH))	9.4.6

Tab. 9-3: Error code classifications

① The diagnostic information of the local station can be confirmed on the Module's Detailed Information screen of GX Works2 (Diagnostics → System Monitor → Detailed Information).

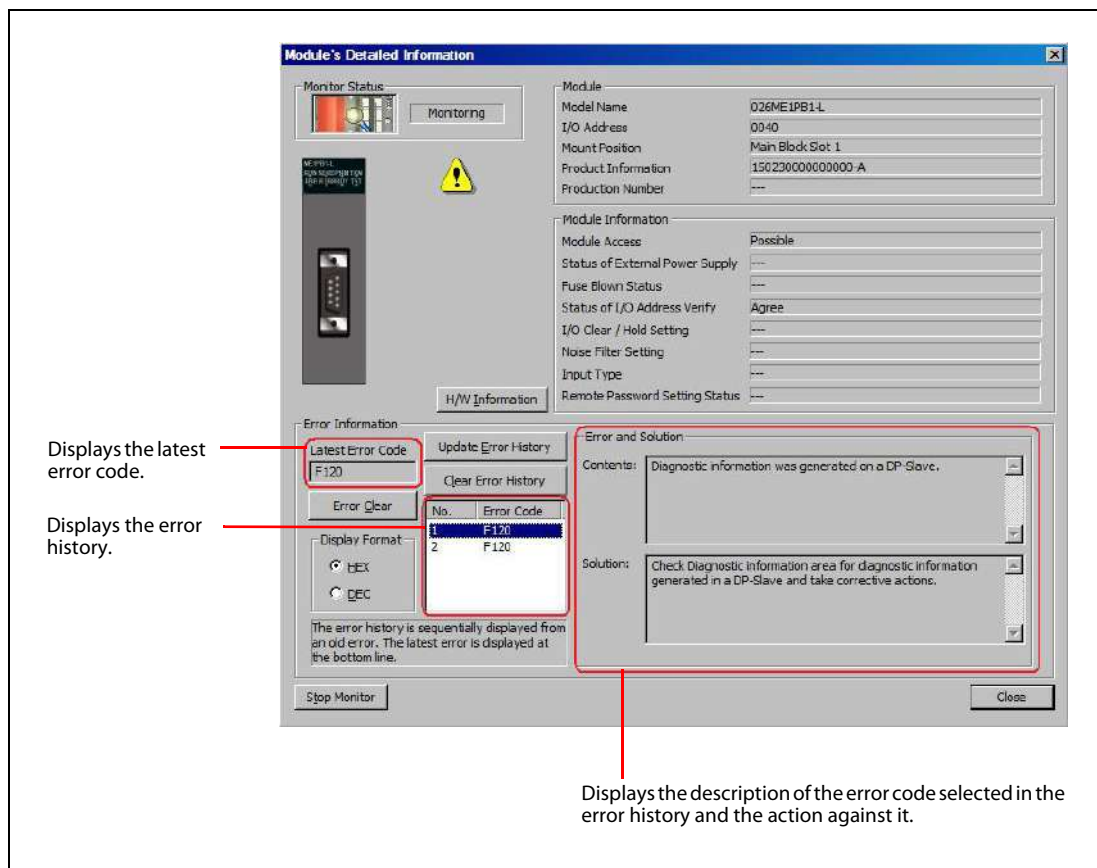

Fig. 9-5: "Module's Detailed Information" screen of GX Works2

9.4.1 Error codes E200_H to E2FF_H (Error codes generated when reading extended diagnostic information)

Error code	Error description	Action
E200 _H	The specified FDL address is out of the range.	Check if the specified FDL address is correct, and retry.
E201 _H	No FDL address has been specified.	
E202 _H	The specified FDL address belongs to the local station (ME1PB1-L).	
E203 _H	The specified FDL address belongs to a reserved or temporarily reserved station.	
E204 _H	No extended diagnostic information is found in the specified FDL address.	
E205 _H	Invalid mode	Change the ME1PB1-L operation mode to mode 3, and retry. When a value is set for Switch 2 of the intelligent function module switches, delete it and leave it as blank (no setting).

Tab. 9-4: Error codes E200_H to E2FF_H

9.4.2 Error codes E300_H to E3A3_H (Error codes generated when switching operation mode)

Error code	Error description	Action
E300 _H	The specified operation mode is invalid.	Check if the operation mode set in Operation mode change request area is correct, and retry.
E301 _H	Parameters have not been written to the module.	After writing parameters, change the mode to Communication mode (mode 3).
E302 _H	Unable to change the operation mode in the current operation status.	After completing the following processing, change the operation mode. Acquisition of extended diagnostic information <ul style="list-style-type: none"> • Global control function • Acyclic communication • Alarm acquisition • Time control function
E303 _H	Failed to write to the flash ROM. Or failed to initialize the flash ROM.	Initialize the flash ROM. If the same error occurs again, replace the ME1PB1-L.
E304 _H	The flash ROM initialization mode processing is incorrect.	Initialize the flash ROM. If the same error occurs again, please consult your local Mitsubishi representative, explaining a detailed description of the problem.
E306 _H	The operation mode was changed during Class2 service execution of Acyclic communication.	After execution of ABORT, change the operation mode.
E3A0 _H	Hardware failure	Please consult your local Mitsubishi representative, explaining a detailed description of the problem.
E3A1 _H		
E3A2 _H		
E3A3 _H		

Tab. 9-5: Error codes E300_H to E3A3_H

**9.4.3 Error codes E400H to E4E3H
(Error codes generated during acyclic communication)**

Error code	Error description	Action
E400H	The FDL address of the target DP-Slave is out of the range.	Check if the specified FDL address is correct, and retry.
E401H	The FDL address specified for the target DP-Slave belongs to the local station (ME1PB1-L).	
E402H	The read data length is incorrect.	Check if the specified read data length is correct, and retry.
E403H	Read error response.	Check the detailed error codes 1 to 3 and take corrective actions.
E404H	The slot number is incorrect.	Check if the specified slot number is correct, and retry.
E405H	The index is incorrect.	Check if the specified index is correct, and retry.
E406H	The CommRef number is incorrect.	Check if the specified CommRef number is correct, and retry.
E407H	Class1 service of Acyclic communication was executed while I/O data exchange is stopped.	Turn ON the Data exchange start request signal (Yn0) to start I/O data exchange. Verify that the bit corresponding to the DP-Slave is ON in the Slave status area (Normal communication detection) (Un\G23040 to Un\G23047) and then retry.
E410H	A physical execution error has been detected.	Check the detailed error codes 2 and 3, and take corrective actions. Verify that the bit corresponding to the DP-Slave is ON in the Slave status area (Normal communication detection) (Un\G23040 to Un\G23047) and then retry.
E411H	Execution error on the protocol was detected.	Check the detailed error codes 2 and 3, and take corrective actions.
E412H	Execution error on the application was detected.	
E420H	Read error was detected on the DP-Slave side.	Check if the request data supported by the DP-Slave is correctly set or not, and retry. For details, refer to the manual for the DP-Slave.
E421H	Write error was detected on the DP-Slave side.	
E422H	Module error was detected on the DP-Slave side.	
E423H	Processing on the DP-Slave side is not available.	
E424H	Application error was detected on the DP-Slave side.	
E425H	Request-not-supported error was detected on the DP-Slave side.	
E426H	Incorrect index was detected on the DP-Slave side.	
E427H	Incorrect data length was detected on the DP-Slave side.	
E428H	Incorrect slot number was detected on the DP-Slave side.	
E429H	Incorrect data type was detected on the DP-Slave side.	
E42AH	Access to an access-disabled area was attempted from the DP-Slave side.	
E42BH	Access is not available on the DP-Slave side.	
E42CH	The access was rejected on the DP-Slave side.	
E42DH	Incorrect access range was detected on the DP-Slave side.	
E42EH	Incorrect request was detected on the DP-Slave side.	
E42FH	Incorrect data type was detected on the DP-Slave side.	
E430H	Incorrect parameter in the request was detected on the DP-Slave side.	
E431H	Resource error was detected during read processing on the DP-Slave side.	
E432H	Resource error was detected during write processing on the DP-Slave side.	
E433H	The resource is already in use on the DP-Slave side.	

Tab. 9-6: Error codes E400H to E4E3H (1)

Error code	Error description	Action
E434H	There is no resource that can be used on the DP-Slave side.	Check if the request data supported by the DP-Slave is correctly set or not, and retry. For details, refer to the manual for the DP-Slave.
E435H	The service not available for the specified DP-Slave was requested.	
E436H	Memories used for request processing are insufficient on the DP-Slave side.	
E437H	The DP-Slave side made this service invalid.	
E438H E439H	The DP-Slave side did not respond to the request	
E440H	The FDL address of the target DP-Slave is out of the range.	Check if the specified FDL address is correct, and retry.
E441H	The FDL address specified for the target DP-Slave belongs to the local station (ME1PB1-L).	
E442H	The write data length is incorrect.	Check if the specified write data length is correct, and retry.
E443H	Write error response	Check the detailed error codes 1 to 3 and take corrective actions.
E444H	The slot number is incorrect.	Check if the specified slot number is correct, and retry.
E445H	The index is incorrect.	Check if the specified index is correct, and retry.
E446H	The CommRef number is incorrect.	Check if the specified CommRef number is correct, and retry.
E447H	Class1 service of Acyclic communication was executed while I/O data exchange is stopped.	Turn ON the Data exchange start request signal (Yn0) to start I/O data exchange. Verify that the bit corresponding to the DP-Slave is ON in the Slave status area (Normal communication detection) (Un\G23040 to Un\G23047) and then retry.
E450H	A physical execution error has been detected	Check the detailed error codes 2 and 3, and take corrective actions. Verify that the bit corresponding to the DP-Slave is ON in the Slave status area (Normal communication detection) (Un\G23040 to Un\G23047) and then retry.
E451H	Execution error on the protocol was detected.	Check the detailed error codes 2 and 3, and take corrective actions.
E452H	Execution error on the application was detected.	
E460H	Read error was detected on the DP-Slave side.	Check if the request data supported by the DP-Slave is correctly set or not, and retry. For details, refer to the manual for the DP-Slave.
E461H	Write error was detected on the DP-Slave side	
E462H	Module error was detected on the DP-Slave side.	
E463H	Processing on the DP-Slave side is not available	
E464H	Application error was detected on the DP-Slave side.	
E465H	Request-not-supported error was detected on the DP-Slave side.	
E466H	Incorrect index was detected on the DP-Slave side.	
E467H	Incorrect data length was detected on the DP-Slave side.	
E468H	Incorrect slot number was detected on the DP-Slave side.	
E469H	Incorrect data type was detected on the DP-Slave side.	
E46AH	Access to an access-disabled area was attempted from the DP-Slave side.	
E46BH	Access is not available on the DP-Slave side.	
E46CH	The access was rejected on the DP-Slave side.	
E46DH	Incorrect access range was detected on the DP-Slave side.	
E46EH	Incorrect request was detected on the DP-Slave side.	
E46FH	Incorrect data type was detected on the DP-Slave side.	
E470H	Incorrect parameter in the request was detected on the DP-Slave side.	
E471H	Resource error was detected during read processing on the DP-Slave side.	
E472H	Resource error was detected during write processing on the DP-Slave side.	

Tab. 9-6: Error codes E400H to E4E3H (2)

Error code	Error description	Action
E473H	The resource is already in use on the DP-Slave side.	Check if the request data supported by the DP-Slave is correctly set or not, and retry. For details, refer to the manual for the DP-Slave.
E474H	There is no resource that can be used on the DP-Slave side.	
E475H	The service not available for the specified DP-Slave was requested.	
E476H	Memories used for request processing are insufficient on the DP-Slave side.	
E477H	The DP-Slave side made this service invalid.	
E478H	The DP-Slave side did not respond to the request.	
E479H		
E480H	The FDL address of the target DP-Slave is out of the range.	Check if the specified FDL address is correct, and retry.
E481H	The FDL address specified for the target DP-Slave belongs to the local station (ME1PB1-L).	
E482H	INITIATE error response	Check the detailed error codes 1 to 3 and take corrective actions.
E483H	Invalid Alignment setting	Check if the specified Alignment is correct, and retry.
E484H	The CommRef number is incorrect.	Check if the specified CommRef number is correct, and retry.
E485H	Total size of S Len and D Len is out of range.	Adjust the total size of S Len and D Len to 230 bytes or less, and retry.
E490H	Physical execution error detected.	Check the detailed error codes 2 and 3, and take corrective actions.
E491H	Execution error on the protocol was detected.	
E492H	Execution error on the application was detected.	
E4A0H	Read error was detected on the DP-Slave side.	Check if the request data supported by the DP-Slave is correctly set or not, and retry. For details, refer to the manual for the DP-Slave.
E4A1H	Write error was detected on the DP-Slave side.	
E4A2H	Module error was detected on the DP-Slave side.	
E4A3H	Processing on the DP-Slave side is not available.	
E4A4H	Application error was detected on the DP-Slave side.	
E4A5H	Request-not-supported error was detected on the DP-Slave side.	
E4A6H	Incorrect index was detected on the DP-Slave side.	
E4A7H	Incorrect data length was detected on the DP-Slave side.	
E4A8H	Incorrect slot number was detected on the DP-Slave side.	
E4A9H	Incorrect data type was detected on the DP-Slave side.	
E4AAH	Access to an access-disabled area was attempted from the DP-Slave side.	
E4ABH	Access is not available on the DP-Slave side.	
E4ACH	The access was rejected on the DP-Slave side.	
E4ADH	Incorrect access range was detected on the DP-Slave side.	
E4AEH	Incorrect request was detected on the DP-Slave side.	
E4AFH	Incorrect data type was detected on the DP-Slave side.	
E4B0H	Incorrect parameter in the request was detected on the DP-Slave side.	
E4B1H	Resource error was detected during read processing on the DP-Slave side.	
E4B2H	Resource error was detected during write processing on the DP-Slave side.	
E4B3H	The resource is already in use on the DP-Slave side.	
E4B4H	There is no resource that can be used on the DP-Slave side.	
E4B5H	The service not available for the specified DP-Slave was requested.	

Tab. 9-6: Error codes E400H to E4E3H (3)

Error code	Error description	Action
E4B6H	Memories used for request processing are insufficient on the DP-Slave side.	Check if the request data supported by the DP-Slave is correctly set or not, and retry. For details, refer to the manual for the DP-Slave.
E4B7H	The DP-Slave side made this service invalid.	
E4B8H	The DP-Slave side did not respond to the request.	
E4C0H	The CommRef number is incorrect.	Check if the specified CommRef number is correct, and retry.
E4D0H	Hardware failure	Please consult your local Mitsubishi representative, explaining a detailed description of the problem.
E4D1H		
E4D2H		
E4D3H		
E4D4H		
E4D5H		
E4D6H		
E4D7H		
E4D8H		
E4D9H		
E4DAH		
E4DBH		
E4DCH		
E4DDH	There is no executable resource.	
E4DEH	There is an invalid parameter setting.	Check the parameter settings and then retry.
E4DFH	<ol style="list-style-type: none"> ① The DP-Slave is not able to respond. ② Because of current processing of a Class2 service, the DP-Slave cannot handle the next service. ③ The INITIATE service has not been executed. ④ A transmission timeout has occurred after execution of the INITIATE service. 	<ol style="list-style-type: none"> ① Check the PROFIBUS cable wiring status and start completion status of the DP-Slave, and then retry. For the start completion status of the DP-Slave, refer to the manual for the DP-Slave. ② When Acyclic communications have been continuously executed to the same DP-Slave, check the execution intervals and retry. For the execution intervals of the Acyclic communication, refer to the manual for the DP-Slave. ③ Retry after execution of the INITIATE service. ④ Increase the set transmission timeout value of the INITIATE service.
E4E0H	No response was received from the DP-Slave.	Check the DP-Slave status and retry.
E4E1H	Any of the following functions are being executed from the same DP-Master to the same DP-Slave. <ul style="list-style-type: none"> • Acyclic communication • Alarm acquisition 	Verify that the processing of the following functions is completed, and retry. <ul style="list-style-type: none"> • Acyclic communication • Alarm acquisition
E4E2H	Hardware failure	Please consult your local Mitsubishi representative, explaining a detailed description of the problem.
E4E3H		

Tab. 9-6: Error codes E400H to E4E3H (4)

9.4.4 Error codes E500H to E5A2H (Error codes generated when reading alarms)

Error code	Error description	Action
E500H	The FDL address of the target DP-Slave is out of the range.	Check if the specified FDL address is correct, and retry.
E501H	The FDL address specified for the target DP-Slave belongs to a non-configured station.	
E502H	The FDL address specified for the target DP-Slave belongs to the local station (ME1PB1-L).	
E503H	The FDL address specified for the target DP-Slave belongs to a reserved or temporarily reserved station.	
E504H	The alarm read request code is incorrect.	Check if the specified request code is correct, and retry.
E505H	The ACK request bit is incorrect.	Check if the bit specified in the buffer memory address 26434 (6742H) is correct, and retry.
E506H	Alarm read error response	Check the detailed error codes 1 to 3 and take corrective actions.
E507H	Currently not exchanging I/O data	Turn ON the Data exchange start request signal (Yn0), and retry.
E508H	There is an error response to the ACK request.	Check the detailed error codes 1 to 3 and take corrective actions.
E510H	Physical execution error was detected	Check the detailed error codes 2 and 3, and take corrective actions.
E520H	Incorrect parameter in the request was detected on the DP-Slave side.	Check if the request data supported by the DP-Slave is correctly set or not, and retry.
E521H	There is no alarm that can be used on the DP-Slave side.	For details, refer to the manual for the DP-Slave.
E530H	Use of the alarm function is not allowed.	Check if the DP-Slave supports the alarm function or not, and retry.
E531H	Invalid DP-Slave status	Check if the DP-Slave is properly exchanging I/O data or not, and retry.
E540H	The FDL address of the target DP-Slave is out of the range.	Check if the specified FDL address is correct, and retry.
E541H	The FDL address specified for the target DP-Slave belongs to a non-configured station.	
E542H	The FDL address specified for the target DP-Slave belongs to the local station (ME1PB1-L).	
E543H	The FDL address specified for the target DP-Slave belongs to a reserved or temporarily reserved station.	
E544H	The alarm type is incorrect.	Check if the alarm data returning ACK is stored in the Alarm response area (Un\G26446 to Un\26768), and retry.
E545H	Alarm ACK request error response	Check the detailed error codes 1 to 3 and take corrective actions.
E546H	The slot number is incorrect.	Check if the alarm data returning ACK is stored in the Alarm response area (Un\G26446 to Un\26768), and retry.
E547H	The sequence number is incorrect.	
E550H	Physical execution error was detected	Check the detailed error codes 2 and 3, and take corrective actions.
E551H	Execution error on the protocol was detected.	
E552H	Execution error on the application was detected.	
E560H	Read error was detected on the DP-Slave side.	Check if the request data supported by the DP-Slave is correctly set or not, and retry. For details, refer to the manual for the DP-Slave.
E561H	Write error was detected on the DP-Slave side.	
E562H	Module error was detected on the DP-Slave side.	
E563H	Processing on the DP-Slave side is not available.	
E564H	Application error was detected on the DP-Slave side.	

Tab. 9-7: Error codes E500H to E5A2H (1)

Error code	Error description	Action
E565H	Request-not-supported error was detected on the DP-Slave side.	Check if the request data supported by the DP-Slave is correctly set or not, and retry. For details, refer to the manual for the DP-Slave.
E566H	Incorrect index was detected on the DP-Slave side	
E567H	Incorrect data length was detected on the DP-Slave side.	
E568H	Incorrect slot number was detected on the DP-Slave side.	
E569H	Incorrect data type was detected on the DP-Slave side.	
E56AH	Access to an access-disabled area was attempted from the DP-Slave side.	
E56BH	Access is not available on the DP-Slave side.	
E56CH	The access was rejected on the DP-Slave side.	
E56DH	Incorrect access range was detected on the DP-Slave side.	
E56EH	Incorrect request was detected on the DP-Slave side.	
E56FH	Incorrect data type was detected on the DP-Slave side.	
E570H	Incorrect parameter in the request was detected on the DP-Slave side.	
E571H	Resource error was detected during read processing on the DP-Slave side.	
E572H	Resource error was detected during write processing on the DP-Slave side.	
E573H	The resource is already in use on the DP-Slave side.	
E574H	There is no resource that can be used on the DP-Slave side.	
E575H	Incorrect parameter exists in the ACK request.	Check the alarm status on the specified DP-Slave and retry.
E576H	There is no alarm for which ACK can be requested.	
E580H		
E581H	The alarm specified for ACK request is not found.	Check if the DP-Slave supports the alarm function or not, and retry.
E582H	Use of the alarm function is not allowed.	
E590H	Hardware failure	Please consult your local Mitsubishi representative, explaining a detailed description of the problem.
E591H		
E592H		
E593H		
E594H		
E595H		
E596H		
E597H		
E598H		
E599H		
E59AH	Verify that the Acyclic communication is completed, and retry.	
E59BH		Acyclic communication is executed to the same DP-Slave.
E59CH		There is no executable resource.
E59DH	There is an invalid parameter setting.	Check the parameter settings and then retry.

Tab. 9-7: Error codes E500H to E5A2H (2)

Error code	Error description	Action
E59EH	<ul style="list-style-type: none"> • The DP-Slave is not able to respond. • Or, because of current processing of a Class2 service, the DP-Slave cannot handle the next service. 	<p>Check the PROFIBUS cable wiring status and start completion status of the DP-Slave, and then retry.</p> <p>When Acyclic communications have been continuously executed to the same DP-Slave, check the execution intervals and retry.</p> <p>For the start completion status of the DP-Slave and the Acyclic communication execution intervals, refer to the manual for the DP-Slave.</p>
E59FH	No response was received from the DP-Slave.	Check the DP-Slave status and retry.
E5A0H	<p>Any of the following functions are being executed from the same DP-Master to the same DP-Slave.</p> <ul style="list-style-type: none"> • Acyclic communication • Alarm acquisition 	<p>Verify that the processing of the following functions is completed, and retry.</p> <ul style="list-style-type: none"> • Acyclic communication • Alarm acquisition
E5A1H	Hardware failure	Please consult your local Mitsubishi representative, explaining a detailed description of the problem.
E5A2H		

Tab. 9-7: Error codes E500H to E5A2H (3)

**9.4.5 Error codes E600H to E62DH
(Error codes generated when executing time control)**

Error code	Error description	Action
E600H	The request code is incorrect.	Check if the request code is correct, and retry.
E601H	No clock data have been written from another time master.	After writing clock data from another time master, execute the time data read request again.
E602H	Hardware failure	Please consult your local Mitsubishi representative, explaining a detailed description of the problem.
E603H		
E604H		
E605H		
E606H		
E611H	The UTC second value set in the Time control setting request area (Un\G26784 to Un\G26792) is out of the range.	Check if the UTC second value is correct, and retry. (Refer to section 7.6.2)
E612H	Hardware failure	Please consult your local Mitsubishi representative, explaining a detailed description of the problem.
E613H		
E614H		
E615H		
E622H		
E623H		
E624H		
E625H		
E626H	Incorrect Year (At the time of write request)	Check if the request data is correct, and retry.
E627H	Incorrect Month (At the time of write request)	
E628H	Incorrect Day (At the time of write request)	
E629H	Inconsistent Date (At the time of write request)	
E62AH	Incorrect Hour (At the time of write request)	
E62BH	Incorrect Minute (At the time of write request)	
E62CH	Incorrect Second (At the time of write request)	
E62DH	Clock data is out of the range. (At the time of write request)	

Tab. 9-8: Error codes E600H to E62DH

**9.4.6 Error codes F100H to FFB1H
(Local diagnostic information of the ME1PB1-L)**

Error code	LED Status	Error description	Action
F100H	ERR. LED ON	FDL address No. of a DP-Slave is duplicated with that of the DP-Master in the parameter settings.	Check the FDL addresses of the DP-Master and DP-Slaves, and set correct parameters without duplication.
F101H	ERR. LED ON	No DP-Slaves are set up for I/O data exchange.	Check the following and correct the setting so that one or more DP-Slaves can exchange I/O data. <ul style="list-style-type: none"> • Is the slave parameter, "Slave is active" checked? • In the temporary slave reservation, haven't all of DP-Slaves been specified as reserved stations?
F102H	ERR. LED ON	Hardware failure	Replace the ME1PB1-L. If the same error occurs again, please consult your local Mitsubishi representative, explaining a detailed description of the problem.
F103H			
F104H			
F105H			
F106H	PRM LED flashing	Parameters have not been written to the flash ROM.	Write the parameters.
F107H	ERR. LED ON	The parameters or operation mode read from the flash ROM are corrupted.	Initialize the flash ROM, and then write the parameters and operation mode. If the same error occurs again, replace the ME1PB1-L.
F108H	ERR. LED ON	Unable to access the flash ROM. Or failed to initialize the flash ROM.	Initialize the flash ROM. If the same error occurs again, replace the ME1PB1-L.
F10BH	ERR. LED ON	Unable to read the operation mode registered to the flash ROM.	Initialize the flash ROM. If the same error occurs again, replace the ME1PB1-L.
F10CH	PRM LED flashing	In the parameter settings, there is a DP-Slave whose I/O data size is set to 0 byte.	Check the slave parameters, and make the setting again to ensure that the I/O data size of each DP-Slave is 1 byte or more.
F10DH	PRM LED flashing	Parameter error	Initialize the flash ROM. If the same error occurs again, please consult your local Mitsubishi representative, explaining a detailed description of the problem.
F10EH	ERR. LED ON	Hardware failure or parameter defined by user is not allowed.	Please check if this error occurs in case of default parameter. Please consult your local Mitsubishi representative, explaining a detailed description of the problem.
F10FH			
F110H	—	Although Data consistency start request signal (YnC) is ON, the BBLKRD instruction is not executed.	Modify the sequence program so that the BBLKRD instruction is executed when Data consistency start request signal (YnC) is ON.
F111H	—	Although Data consistency start request signal (YnC) is ON, the BBLKWR instruction is not executed.	Modify the sequence program so that the BBLKWR instruction is executed when Data consistency start request signal (YnC) is ON.
F112H	—	Although Data consistency start request signal (YnC) is ON, the BBLKRD and BBLKWR instructions are not executed.	Modify the sequence program so that the BBLKRD and BBLKWR instructions are executed when Data consistency start request signal (YnC) is ON.
F113H	—	Data consistency start request signal (YnC) was turned ON during execution of the data consistency function in automatic refresh.	The data consistency function in automatic refresh and dedicated instructions are not concurrently executable. In the master parameter setting of the intelligent function utility, disable the data consistency function. (Section 6.3)

Tab. 9-9: Error codes F100H to FFB1H (1)

Error code	LED Status	Error description	Action
F120H	R ERR. LED ON	Diagnostic information was generated on a DP-Slave.	Check Diagnostic information area for diagnostic information generated in a DP-Slave and take corrective actions.
F121H	R ERR. LED ON	There is a DP-Master or DP-Slave that has a duplicated FDL address on the same line.	Check the FDL addresses of the DP-Master and DP-Slaves, and set correct parameters without duplication.
F122H	R ERR. LED ON	An error has been detected on the line. Or, some master parameter is not appropriate.	Check the wiring status of the bus terminator(s) and PROFIBUS cable(s). If the terminating resistor and PROFIBUS cable wiring status is correct, increase the set value of the master parameter, "Min. slave interval".
F123H			
F124H			
F125H	R ERR. LED ON	The DP-Master is in the clear request transmission status.	Since "Error action flag" is check-marked in the master parameter settings, the clear request has been sent to all DP-Slaves. To disable transmission of the clear request, uncheck "Error action flag".
F126H	R ERR. LED ON	An error has been detected on the line. Short-circuit of PROFIBUS cable has been detected.	Check the wiring status and the bus terminator(s).
F1FEH	ERR. LED ON	Hardware failure	Please consult your local Mitsubishi representative, explaining a detailed description of the problem.
F1FFH			
FF90H	—	Dedicated instruction BBLKRD is not executed.	Check the sequence program.
FF91H	—	Dedicated instruction BBLKWR is not executed.	
FFA0H	ERR. LED ON	The data in the flash ROM is corrupted.	Clear flash ROM and write the parameter again. After that, if same error occurs, please consult your local Mitsubishi representative, explaining a detailed description of the problem.
FFA1H			
FFA2H			
FFA3H			
FFA4H	PRM LED flashing		
FFA5H			
FFA6H			
FFA7H			
FFB0H	ERR. LED ON	RAM failure	Replace the module with a new one.
FFB1H			

Tab. 9-9: Error codes F100H to FFB1H (2)

9.5 How to Return the ME1PB1-L to its Factory-set Conditions

This procedure initializes (clears) the flash ROM of the ME1PB1-L. Because of protecting from unwilling erase, the following steps are necessary to erase data.

Perform this procedure, for example, when parameters in the flash ROM are corrupted (The PRM LED is flashing).

- ① Stop the LCPU
- ② Connect the GX Works2 to the LCPU, and perform the following steps ③ to ⑬ by using the Device test on the GX Works2.
- ③ Write 9_H to the Operation mode change request area (Un\G2255) of the ME1PB1-L.
- ④ Turn ON the Operation mode change request signal (Y(n+1)1).
- ⑤ When the Operation mode change completed signal (X(n+1)X(n+1)1) has turned ON, turn OFF the Operation mode change request signal (Y(n+1)1).
- ⑥ Write F_H to the Operation mode change request area (Un\G2255) of the ME1PB1-L.
- ⑦ Turn ON the Operation mode change request signal (Y(n+1)1).
- ⑧ When the Operation mode change completed signal (X(n+1)1) has turned ON, turn OFF the Operation mode change request signal (Y(n+1)1).
- ⑨ Write A_H to the Operation mode change request area (Un\G2255) of the ME1PB1-L.
- ⑩ Turn ON the Operation mode change request signal (Y(n+1)1).
- ⑪ When the Operation mode change completed signal (X(n+1)1) has turned ON, turn OFF the Operation mode change request signal (Y(n+1)1).
- ⑫ The TST LED turns ON, and the processing for returning the ME1PB1-L to its factory-set conditions is started.
- ⑬ When the processing is completed, the following status will be identified.
 - When normally completed: The TST LED turns OFF.
 - When failed: The TST and ERR. LEDs are ON.

When the processing has failed, please consult your local Mitsubishi representative, explaining a detailed description of the problem.

- ⑭ Reapply power to or reset the LCPU

The PRM LED on the ME1PB1-L turns ON, and the ME1PB1-L starts in the Parameter setting mode (mode 1).

Write the ME1PB1-L parameters on GX Works2.

A Appendix

A.1 External Dimensions

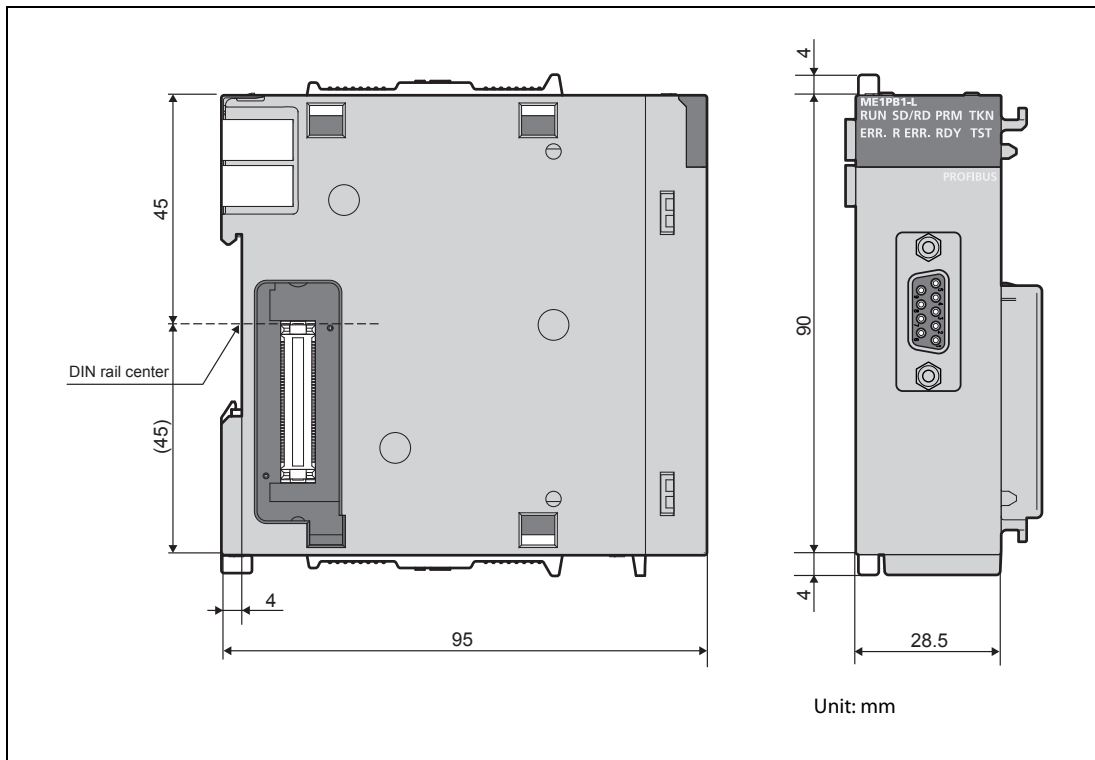

Fig. A-1: External dimensions of the ME1PB1-L

Index

A

- ABORT service (Class2_SERVICE) 7-28
- Acyclic communication
 - Area in buffer memory 3-42
 - Request area 3-42
 - Request execution instruction area 3-43
 - Request result area 3-44
 - Response area 3-45
 - with DP-Slaves 4-10
- Address information area (for mode 3) 3-25
- Alarm
 - ACK request 7-36
 - Acquisition 4-12
 - Request area 3-46
 - Response area 3-46
- Alarm area 3-46
- Alarm read
 - Request (with ACK) 7-41
 - Request (without ACK) 7-33
 - Request signal (Y(n+1)8) 3-14
 - Response signal (X(n+1)8) 3-14
- All stations'
 - Alarm status 3-33
 - Diagnostic status 3-30
- Automatic refresh
 - for data exchange with
CC-Link IE Head module 7-58
 - Parameter setting 6-12
 - Settings in intelligent function utility 5-12

B

- Buffer memory
 - List 3-17
 - Structure 3-16
- Bus cycle time 3-49
 - Area in buffer memory 3-40
 - Calculation example 3-51
- Bus parameters 6-6

C

- Communication READY signal (X(n+1)B) 3-15
- Connector for PROFIBUS 5-6
- Current bus cycle time (storage in buffer memory) 3-40
- Current diagnostic information
non-notification time area 3-34
- Current operation mode area 3-20

D

- Data consistency
 - Overview 4-19
 - Request signal (XnC) 3-12
 - Start request signal (YnC) 3-12
- Data exchange start
 - Completed signal (Xn0) 3-7
 - Request signal (Yn0) 3-7
- Data swap function 4-17
- Diagnostic information
 - Acquisition 4-4
 - Area clear request signal (Yn2) 3-9
 - Area cleared signal (Xn2) 3-9
 - Area in buffer memory 3-34
 - Area in buffer memory (for mode 3) 3-36
 - Detection reset request signal (Yn1) 3-8
 - Detection signal (Xn1) 3-8
 - Invalid setting area 3-35
 - Non-notification time setting area 3-34

E

Each station's	
Alarm status	3-33
Diagnostic status	3-30
Error check using the LEDs	9-2
Error Codes	9-7
Extended diagnostic information	
Acquisition	4-4
Area in buffer memory (for mode 3)	3-38
Read area	3-39
Read request area	3-39
Read response area	3-39
Read response signal (Xn6)	3-11
Read request signal (Yn6)	3-11

F

Flash ROM storage mode	3-20
Function version	2-1
Functions (Overview)	4-1

G

G. BBLKRD instruction	8-4
G. BBLKWR instruction	8-6
Global control	
Area in buffer memory	3-40
Completed signal (Xn4)	3-10
Failed signal (Xn5)	3-10
Overview	4-6
Request signal (Yn4)	3-10
GX Works2	
Auto refresh	5-12
New intelligent function module	5-9
Parameter setting for intelligent function modules	5-11

I

I/O data exchange	
Area in buffer memory	3-22
Overview	4-2
I/O signals	3-6
INITIATE service (Class2_SERVICE)	7-25
Input data area (for mode 3)	3-23
Input data start address area (for mode 3)	3-25

Instructions

BBLKRD	8-4
BBLKWR	8-6

L

LEDs

Status check on GX Works2	9-3
Troubleshooting	9-2
Local FDL address display area	3-21
Local station	
Error information area	3-20

M

Master parameters	6-4
Max. bus cycle time (storage in buffer memory)	3-40
ME1PB1-L	
Data flow	3-4
External dimensions	A-1
I/O signals	3-6
LEDs	5-4
Performance specifications	3-2
Return to factory-set conditions	9-19
Self-diagnostics	5-5
Min. bus cycle time (storage in buffer memory)	3-40
Module READY signal (X(n+1)D)	3-15

O

Offline test status area	3-21
Operation mode change	
Area (Overview)	3-21
Completed signal (X(n+1)1)	3-13
Request area	3-21
Request signal (Y(n+1)1)	3-13
Result area	3-21
Operation mode setting	6-2
Operation mode signal (X(n+1)0)	3-12
Output data area (for mode 3)	3-24
Output data start address area (for mode 3)	3-26
Output status setting for the case of a CPU stop error	4-22

P

Parameter setting	6-1
Parameter setting status area	
Active station	3-31
Reserved station	3-31
PROFIBUS	
Cable	5-6
Connector	5-6
PROFIBUS DP network configuration	2-2
PROFIBUS DPV0 Functions	4-2
PROFIBUS DPV1 Functions	4-10
PROFIBUS DPV2 Functions	4-15

R

READ services (Class1_SERVICE, Class2_SERVICE) .	7-19
Restart request signal (YnD)	3-12

S

Self-diagnostics	5-5
Slave parameters	6-8
Slave status area	
Alarm detection	3-33
Diagnostic information detection	3-30
Normal communication detection	3-27
Operation status of DP-Slaves	3-27
Reserved station setting status	3-29

T

Temporary slave reservation	
Area in buffer memory	3-47
Overview	4-24
Request area	3-47
Status area	3-32
Time control area	3-46
Time control over DP-Slaves	4-15
Time control setting	
Request area	3-46
Response area	3-46
Time control start	
Request signal (Y(n+1)9)	3-14
Response signal (X(n+1)9)	3-14
Time data	
Read request	7-50
Write request	7-52
Write request (UTC format)	7-51
Transmission delay time	3-53
Transmission distance	3-3

W

Watchdog timer error signal (X(n+1)F)	3-15
Wiring specifications for bus terminator	5-7
WRITE services (Class1_SERVICE, Class2_SERVICE) .	7-22

HEADQUARTERS		EUROPEAN REPRESENTATIVES		EUROPEAN REPRESENTATIVES		EURASIAN REPRESENTATIVES	
MITSUBISHI ELECTRIC EUROPE B.V. German Branch Gothaer Straße 8 D-40880 Ratingen Phone: +49 (0)2102 / 486-0 Fax: +49 (0)2102 / 486-1120	EUROPE	GEVA Wiener Straße 89 A-2500 Baden Phone: +43 (0)2252 / 85 55 20 Fax: +43 (0)2252 / 488 60	AUSTRIA	ALFATRADE Ltd. 99, Paola Hill Malta-Paola PLA 1702 Phone: +356 (0)21 / 697 816 Fax: +356 (0)21 / 697 817	MALTA	T00 Kazpromavtomatika UL. ZHAMBYLA 28, KAZ-100017 Karaganda Phone: +7 7212 / 50 10 00 Fax: +7 7212 / 50 11 50	KAZAKHSTAN
MITSUBISHI ELECTRIC EUROPE B.V.-org.sl. Czech Branch Radlická 751/113e Avenir Business Park CZ-158 00 Praha 5 Phone: +420 (0) 251 / 551 470 Fax: +420 (0) 251 / 551 471	CZECH REP.	000 "TECHNIKON" Prospect Nezavisimosti 177-9 BY-220125 Minsk Phone: +375 (0)17 / 393 1177 Fax: +375 (0)17 / 393 0081	BELARUS	INTEHSIS SRL bld. Traian 23/1 MD-2060 Kishinev Phone: +373 (0)22 / 66 4242 Fax: +373 (0)22 / 66 4280	MOLDOVA	MIDDLE EAST REPRESENTATIVE	
MITSUBISHI ELECTRIC EUROPE B.V. French Branch 25, Boulevard des Bouvets F-92741 Nanterre Cedex Phone: +33 (0)1 / 55 68 55 68 Fax: +33 (0)1 / 55 68 57 57	FRANCE	ESCO DRIVES Culliganlaan 3 BE-1831 Diegem Phone: +32 (0)2 / 717 64 60 Fax: +32 (0)2 / 717 64 61	BELGIUM	HIFLEX AUTOM. B.V. Wolweverstraat 22 NL-2984 CD Ridderkerk Phone: +31 (0)180 / 46 60 04 Fax: +31 (0)180 / 44 23 55	NETHERLANDS	I.C. SYSTEMS Ltd. 23 Al-Saad-Al-Alee St. EG-Sarayut, Maadi, Cairo Phone: +20 (0) 2 / 235 98 548 Fax: +20 (0) 2 / 235 96 625	EGYPT
MITSUBISHI ELECTRIC EUROPE B.V. Irish Branch Westgate Business Park, Ballymount IRL-Dublin 24 Phone: +353 (0)1 4198800 Fax: +353 (0)1 4198890	IRELAND	KONING & HARTMAN B.V. Woluwelaan 31 BE-1800 Vilvoorde Phone: +32 (0)2 / 257 02 40 Fax: +32 (0)2 / 257 02 49	BELGIUM	KONING & HARTMAN B.V. Haarlerbergweg 21-23 NL-1101 CH Amsterdam Phone: +31 (0)20 / 587 76 00 Fax: +31 (0)20 / 587 76 05	NETHERLANDS	GIRIT CELADON Ltd. 12 H'aomanut Street IL-42505 Netanya Phone: +972 (0)9 / 863 39 80 Fax: +972 (0)9 / 885 24 30	ISRAEL
MITSUBISHI ELECTRIC EUROPE B.V. Italian Branch Viale Colleoni 7 Palazzo Sirio I-20864 Agrate Brianza (MB) Phone: +39 039 / 60 53 11 Fax: +39 039 / 60 53 312	ITALY	INEA RBT d.o.o. Stegne 11 SI-1000 Ljubljana Phone: +386 (0)1 / 513 8116 Fax: +386 (0)1 / 513 8170	BOSNIA AND HERZEGOVINA	Beijer Electronics AS Postboks 487 NO-3002 Drammen Phone: +47 (0)32 / 24 30 00 Fax: +47 (0)32 / 84 85 77	NORWAY	ILAN & GAVISH Ltd. 24 Shenkar St., Kiryat Ariet IL-49001 Petah-Tikva Phone: +972 (0)3 / 922 18 24 Fax: +972 (0)3 / 924 0761	ISRAEL
MITSUBISHI ELECTRIC EUROPE B.V. Polish Branch ul. Krakowska 50 PL-32-083 Balice Phone: +48 (0) 12 630 47 00 Fax: +48 (0) 12 630 47 01	POLAND	AKHNATON 4, Andrei Ljapchev Blvd., PO Box 21 BG-1756 Sofia Phone: +359 (0)2 / 817 6000 Fax: +359 (0)2 / 97 44 06 1	BULGARIA	Fonseca S.A. R. João Francisco do Casal 87/89 PT-3801-997 Aveiro, Esqueira Phone: +351 (0)234 / 303 900 Fax: +351 (0)234 / 303 910	PORTUGAL	CEG LIBAN Cebaco Center/Block A Autostrade DORA Lebanon-Beirut Phone: +961 (0)1 / 240 445 Fax: +961 (0)1 / 240 193	LEBANON
MITSUBISHI ELECTRIC EUROPE B.V. Russian Branch 52, bld. 3 Kosmodamianskaya nab 8 floor RU-115054 Moscow Phone: +7 495 / 721 2070 Fax: +7 495 / 721 2071	RUSSIA	INEA CR Losinjska 4 a HR-10000 Zagreb Phone: +385 (0)1 / 36 940 - 01 / -02 / -03 Fax: +385 (0)1 / 36 940 - 03	CROATIA	SIRIUS TRADING & SERVICES SRL Aleea Lacul Morii Nr. 3 RO-060841 Bucuresti, Sector 6 Phone: +40 (0)21 / 430 40 06 Fax: +40 (0)21 / 430 40 02	ROMANIA	AFRICAN REPRESENTATIVE	
MITSUBISHI ELECTRIC EUROPE B.V. Spanish Branch Carretera de Rubí 76-80 Apdo. 420 E-08190 Sant Cugat del Vallés (Barcelona) Phone: +34 (0) 93 / 5653131 Fax: +34 (0) 93 / 5891579	SPAIN	AutoCont C. S. S.R.O. Kafkova 1853/3 CZ-702 00 Ostrava 2 Phone: +420 595 691 150 Fax: +420 595 691 199	CZECH REPUBLIC	INEA SR Izletnicka 10 SER-113000 Smederevo Phone: +381 (0)26 / 615 401 Fax: +381 (0)26 / 615 401	SERBIA	ADROIT TECHNOLOGIES 20 Waterford Office Park 189 Witkoppen Road ZA-Fourways Phone: +27 (0)11 / 658 8100 Fax: +27 (0)11 / 658 8101	SOUTH AFRICA
MITSUBISHI ELECTRIC EUROPE B.V. UK Branch Travellers Lane UK-Hatfield, Herts. AL10 8XB Phone: +44 (0)1707 / 28 87 80 Fax: +44 (0)1707 / 27 86 95	UK	Beijer Electronics A/S Lykkegardsvej 17 DK-4000 Roskilde Phone: +45 (0)46 / 75 76 66 Fax: +45 (0)46 / 75 56 26	DENMARK	SIMAP s.r.o. Jána Derku 1671 SK-911 01 Trenčín Phone: +421 (0)32 743 04 72 Fax: +421 (0)32 743 75 20	SLOVAKIA		
MITSUBISHI ELECTRIC EUROPE B.V. Tokyo Building 2-7-3 Marunouchi, Chiyoda-ku Tokyo 100-8310 Phone: +81 (3) 3218-2111 Fax: +81 (3) 3218-2185	JAPAN	Beijer Electronics Eesti OÜ Pärnu mnt. 160i EE-11317 Tallinn Phone: +372 (0)6 / 51 81 40 Fax: +372 (0)6 / 51 81 49	ESTONIA	INEA RBT d.o.o. Stegne 11 SI-1000 Ljubljana Phone: +386 (0)1 / 513 8116 Fax: +386 (0)1 / 513 8170	SLOVENIA		
MITSUBISHI ELECTRIC CORPORATION Tokyo Building 2-7-3 Marunouchi, Chiyoda-ku Tokyo 100-8310 Phone: +81 (3) 3218-2111 Fax: +81 (3) 3218-2185	JAPAN	Beijer Electronics OY Vanha Nurmijärventie 62 FIN-01670 Vantaa Phone: +358 (0)207 / 463 500 Fax: +358 (0)207 / 463 501	FINLAND	Beijer Electronics Automation AB Box 426 SE-20124 Malmö Phone: +46 (0)40 / 35 86 00 Fax: +46 (0)40 / 93 23 01	SWEDEN		
MITSUBISHI ELECTRIC AUTOMATION, Inc. 500 Corporate Woods Parkway Vernon Hills, IL 60061 Phone: +1 (847) 478-2100 Fax: +1 (847) 478-0328	USA	PROVENDOR OY Teljänkatu 8 A3 FIN-28130 Pori Phone: +358 (0) 2 / 522 3300 Fax: +358 (0) 2 / 522 3322	FINLAND	OMNI RAY AG Im Schörli 5 CH-8600 Dübendorf Phone: +41 (0)44 / 802 28 80 Fax: +41 (0)44 / 802 28 28	SWITZERLAND		
		UTECA A.B.E.E. 5, Mavrogenous Str. GR-18542 Piraeus Phone: +30 211 / 1206 900 Fax: +30 211 / 1206 999	GREECE	Fabrika Otomasyonu Merkezi Şerifali Mahallesi Nutuk Sokak No.5 TR-34775 Ümraniye-İSTANBUL Phone: +90 (0)216 / 526 39 90 Fax: +90 (0)216 / 526 39 95	TURKEY		
		MELTRADE Ltd. Fertő utca 14. HU-1107 Budapest Phone: +36 (0)1 / 431-9726 Fax: +36 (0)1 / 431-9727	HUNGARY	000 "CSC-AUTOMATION" 4-B, M. Raskovoyi St. UA-02660 Kiev Phone: +380 (0)44 / 494 33 44 Fax: +380 (0)44 / 494-33-66	UKRAINE		
		Beijer Electronics SIA RITAUSMAS IELA 23 LV-1058 Riga Phone: +371 (0)6-784 2280 Fax: +371 (0)6-784 2281	LATVIA				
		Beijer Electronics UAB Goštautų g. 3 LT-48324 Kaunas Phone: +370 37 262707 Fax: +370 37 455605	LITHUANIA				